

STC Catalog Valves & Pneumatic Components



connects *fluid* power to industrial automation™

Tel: (650) 856-8833 | www.StcValve.com

Table of Contents

<p>Section A</p>	<p>Composite Push-in Air Fittings</p>	
<p>Section B</p>	<p>Stainless Steel Push-In Fittings Compression Fittings</p>	
<p>Section C</p>	<p>Solenoid Process Valves & Manual Valves</p>	
<p>Section D</p>	<p>Air & Electric Actuated Valves</p>	
<p>Section E</p>	<p>Air Filter-Regulator-Lubricators</p>	
<p>Section F</p>	<p>Air Solenoid & Air Pilot Valves</p>	
<p>Section G</p>	<p>Manual Air Valves</p>	
<p>Section H</p>	<p>Air Cylinders</p>	

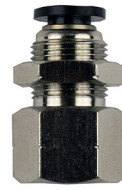

Precision Engineered

Fine Quality



Advanced Design



Excellent Prices



Contents

Fittings Numbering System.....	A2
Composite Push-In Air Fittings List Price.....	A3 - A5
Composite Push-In Fittings Specifications.....	A6
Push-In Fittings Dimensions.....	A7 - A13
Composite Angle Flow Control Air Valves Flow Rate.....	A14

Ordering Part No. =
(e.g., BC 1/8 10-32)

BC

1/8

10-32

Fitting Name	
Branch Tee	BT
Bulkhead Connector	BC
Bulkhead Union	BU
Compact Male Connector	CC
Control Valve (Meter-In Tube)	CI
Control Valve (Meter-Out Tube)	CV
Cross Union	CU
Elbow Reducer	ER
Elbow Union	EU
Extended Elbow	EE
Female Connector	FC
Female Elbow	FE
Flow Control Valve (Inline)	FV
Male Angle	MA
Male Connector	MC
Male Elbow	ME
Male Manifold	MM
Manifold Union	MU
Plug	PG
Plug-In Elbow	PE
Reduced Branch	RB
Reduced Union	RU
Run Tee	RT
Stack Elbow	SE
Stem Coupler	SC
Stem Reducer	SR
Straight Union	SU
Tee Union	TU
Tee Union Reducer	TU
Tube Reducer	TR
Universal Elbow	UE
Y Connector	YC
Y Reducer	YR
Y Union	YU

Tube OD	
Inches	1/8
	5/32
	3/16
	1/4
	5/16
	3/8
	1/2
mm	4
	6
	8
	10
	12
	16

Thread Size / Stem / Tube	
Thread Size: N = NPT R = BSPT (British Standard Taper Thread) G = BSPP (British Standard Parallel Thread) U = Univer- sal Thread (fits NPT, R, & G)	10-32
	N1/8
	N1/4
	N3/8
	N1/2
	M5
	M6
	R1/8
	R1/4
	R3/8
	R1/2
	G1/8
	G1/4
Stem Size	G3/8
	U1/8
	U1/4
	U3/8
	U1/2
	1/8-1/2"
	4-12mm







Options—Release Button Color	
Purple / Metal Finish	(leave blank)
Black	K

Composite Fittings													
Model		Male Connector (with Internal Hex)		Compact Male Connector (with Internal Hex)		Male Elbow		Branch Tee		Run Tee		Y Connector	
		MC		CC		ME		BT		RT		YC	
Tube OD	Pipe Size	Part No.	Unit Price	Part No.	Unit Price	Part No.	Unit Price	Part No.	Unit Price	Part No.	Unit Price	Part No.	Unit Price
1/8	10-32UNF	MC 1/8 10-32 K	\$1.64	CC 1/8 10-32 K	\$1.64	ME 1/8 10-32 K	\$2.34	BT 1/8 10-32 K	\$3.63	RT 1/8 10-32 K	\$3.32	YC 1/8 10-32 K	\$3.32
1/8	NPT1/8	MC 1/8 N1/8 K	\$1.64	CC 1/8 N1/8 K	\$1.64	ME 1/8 N1/8 K	\$2.34	BT 1/8 N1/8 K	\$3.63	RT 1/8 N1/8 K	\$3.65	YC 1/8 N1/8 K	\$3.32
1/8	NPT1/4	MC 1/8 N1/4 K	\$1.64	CC 1/8 N1/4 K	\$1.64	ME 1/8 N1/4 K	\$2.34	BT 1/8 N1/4 K	\$3.63			YC 1/8 N1/4 K	\$3.32
5/32	10-32UNF	MC 5/32 10-32 K	\$1.64	CC 5/32 10-32 K	\$1.73	ME 5/32 10-32 K	\$2.34	BT 5/32 10-32 K	\$3.63	RT 5/32 10-32 K	\$3.32	YC 5/32 10-32 K	\$3.32
5/32	NPT1/8	MC 5/32 N1/8 K	\$1.64	CC 5/32 N1/8 K	\$1.64	ME 5/32 N1/8 K	\$2.34	BT 5/32 N1/8 K	\$3.63	RT 5/32 N1/8 K	\$3.32	YC 5/32 N1/8 K	\$3.32
5/32	NPT1/4	MC 5/32 N1/4 K	\$1.67	CC 5/32 N1/4 K	\$1.64	ME 5/32 N1/4 K	\$2.34	BT 5/32 N1/4 K	\$3.63	RT 5/32 N1/4 K	\$3.65	YC 5/32 N1/4 K	\$3.32
3/16	10-32UNF	MC 3/16 10-32 K	\$1.64			ME 3/16 10-32 K	\$2.34	BT 3/16 10-32 K	\$3.63	RT 3/16 10-32 K	\$3.65	YC 3/16 10-32 K	\$3.65
3/16	NPT1/8	MC 3/16 N1/8 K	\$1.64			ME 3/16 N1/8 K	\$2.34	BT 3/16 N1/8 K	\$3.63	RT 3/16 N1/8 K	\$3.65	YC 3/16 N1/8 K	\$3.65
3/16	NPT1/4	MC 3/16 N1/4 K	\$1.64			ME 3/16 N1/4 K	\$2.34	BT 3/16 N1/4 K	\$3.63	RT 3/16 N1/4 K	\$3.65	YC 3/16 N1/4 K	\$3.65
3/16	NPT3/8	MC 3/16 N3/8 K	\$1.64			ME 3/16 N3/8 K	\$2.34	BT 3/16 N3/8 K	\$3.63	RT 3/16 N3/8 K	\$3.65	YC 3/16 N3/8 K	\$3.65
1/4	10-32UNF	MC 1/4 10-32 K	\$1.64	CC 1/4 10-32 K	\$1.82	ME 1/4 10-32 K	\$2.34	BT 1/4 10-32 K	\$3.63	RT 1/4 10-32 K	\$4.39	YC 1/4 10-32 K	\$3.65
1/4	NPT1/8	MC 1/4 N1/8 K	\$1.64	CC 1/4 N1/8 K	\$1.64	ME 1/4 N1/8 K	\$2.34	BT 1/4 N1/8 K	\$3.66	RT 1/4 N1/8 K	\$5.01	YC 1/4 N1/8 K	\$3.65
1/4	NPT1/4	MC 1/4 N1/4 K	\$1.73	CC 1/4 N1/4 K	\$1.68	ME 1/4 N1/4 K	\$2.34	BT 1/4 N1/4 K	\$3.96	RT 1/4 N1/4 K	\$5.01	YC 1/4 N1/4 K	\$3.95
1/4	NPT3/8	MC 1/4 N3/8 K	\$2.34	CC 1/4 N3/8 K	\$3.49	ME 1/4 N3/8 K	\$2.79	BT 1/4 N3/8 K	\$4.39	RT 1/4 N3/8 K	\$5.48	YC 1/4 N3/8 K	\$4.39
1/4	NPT1/2	MC 1/4 N1/2 K	\$3.86			ME 1/4 N1/2 K	\$5.37						
5/16	NPT1/8	MC 5/16 N1/8 K	\$1.73	CC 5/16 N1/8 K	\$1.68	ME 5/16 N1/8 K	\$2.60	BT 5/16 N1/8 K	\$4.12	RT 5/16 N1/8 K	\$4.56	YC 5/16 N1/8 K	\$4.12
5/16	NPT1/4	MC 5/16 N1/4 K	\$1.82	CC 5/16 N1/4 K	\$2.45	ME 5/16 N1/4 K	\$2.60	BT 5/16 N1/4 K	\$4.12	RT 5/16 N1/4 K	\$5.01	YC 5/16 N1/4 K	\$4.12
5/16	NPT3/8	MC 5/16 N3/8 K	\$2.34	CC 5/16 N3/8 K	\$2.45	ME 5/16 N3/8 K	\$2.96	BT 5/16 N3/8 K	\$4.56	RT 5/16 N3/8 K	\$5.48	YC 5/16 N3/8 K	\$4.56
3/8	NPT1/8	MC 3/8 N1/8 K	\$2.43	CC 3/8 N1/8 K	\$3.49	ME 3/8 N1/8 K	\$3.16	BT 3/8 N1/8 K	\$4.39	RT 3/8 N1/8 K	\$5.48	YC 3/8 N1/8 K	\$4.58
3/8	NPT1/4	MC 3/8 N1/4 K	\$2.51	CC 3/8 N1/4 K	\$3.49	ME 3/8 N1/4 K	\$3.16	BT 3/8 N1/4 K	\$4.58	RT 3/8 N1/4 K	\$5.48	YC 3/8 N1/4 K	\$4.56
3/8	NPT3/8	MC 3/8 N3/8 K	\$3.49	CC 3/8 N3/8 K	\$3.49	ME 3/8 N3/8 K	\$3.71	BT 3/8 N3/8 K	\$4.91	RT 3/8 N3/8 K	\$5.87	YC 3/8 N3/8 K	\$4.84
3/8	NPT1/2	MC 3/8 N1/2 K	\$3.63	CC 3/8 N1/2 K	\$3.49	ME 3/8 N1/2 K	\$5.38	BT 3/8 N1/2 K	\$6.38	RT 3/8 N1/2 K	\$6.36	YC 3/8 N1/2 K	\$5.87
1/2	NPT1/4	MC 1/2 N1/4 K	\$3.49	CC 1/2 N1/4 K	\$4.72	ME 1/2 N1/4 K	\$5.38	BT 1/2 N1/4 K	\$5.87	RT 1/2 N1/4 K	\$5.87	YC 1/2 N1/4 K	\$5.87
1/2	NPT3/8	MC 1/2 N3/8 K	\$3.49	CC 1/2 N3/8 K	\$4.79	ME 1/2 N3/8 K	\$5.38	BT 1/2 N3/8 K	\$6.01	RT 1/2 N3/8 K	\$6.38	YC 1/2 N3/8 K	\$5.87
1/2	NPT1/2	MC 1/2 N1/2 K	\$4.02	CC 1/2 N1/2 K	\$4.95	ME 1/2 N1/2 K	\$5.38	BT 1/2 N1/2 K	\$6.62	RT 1/2 N1/2 K	\$6.79	YC 1/2 N1/2 K	\$6.36

4 mm	M5X0.8	MC 4 M5 K	\$1.64			ME 4 M5 K	\$2.34	BT 4 M5 K	\$3.32	RT 4 M5 K	\$3.32	YC 4 M5 K	\$3.32
4 mm	M6X1	MC 4 M6 K	\$1.64			ME 4 M6 K	\$2.34	BT 4 M6 K	\$3.32	RT 4 M6 K	\$3.32	YC 4 M6 K	\$3.32
4 mm	R1/8	MC 4 R1/8 K	\$1.64			ME 4 R1/8 K	\$2.34	BT 4 R1/8 K	\$3.63	RT 4 R1/8 K	\$3.32	YC 4 R1/8 K	\$3.32
4 mm	R1/4	MC 4 R1/4 K	\$1.64			ME 4 R1/4 K	\$2.34	BT 4 R1/4 K	\$3.63	RT 4 R1/4 K	\$3.63	YC 4 R1/4 K	\$3.63
6 mm	M5X0.8	MC 6 M5 K	\$1.64			ME 6 M5 K	\$2.34	BT 6 M5 K	\$3.65	RT 6 M5 K	\$4.39	YC 6 M5 K	\$3.65
6 mm	M6X1	MC 6 M6 K	\$1.64			ME 6 M6 K	\$2.34	BT 6 M6 K	\$3.65	RT 6 M6 K	\$4.39	YC 6 M6 K	\$3.65
6 mm	R1/8	MC 6 R1/8 K	\$1.64			ME 6 R1/8 K	\$2.34	BT 6 R1/8 K	\$3.63	RT 6 R1/8 K	\$4.39	YC 6 R1/8 K	\$3.65
6 mm	R1/4	MC 6 R1/4 K	\$1.64			ME 6 R1/4 K	\$2.34	BT 6 R1/4 K	\$3.95	RT 6 R1/4 K	\$5.01	YC 6 R1/4 K	\$3.95
6 mm	R3/8	MC 6 R3/8 K	\$2.34			ME 6 R3/8 K	\$2.79	BT 6 R3/8 K	\$4.39	RT 6 R3/8 K	\$5.48	YC 6 R3/8 K	\$4.39
6 mm	R1/2	MC 6 R1/2 K	\$3.23			ME 6 R1/2 K	\$4.60	BT 6 R1/2 K	\$5.87	RT 6 R1/2 K	\$6.36	YC 6 R1/2 K	\$5.87
8 mm	R1/8	MC 8 R1/8 K	\$1.64			ME 8 R1/8 K	\$2.60	BT 8 R1/8 K	\$4.12	RT 8 R1/8 K	\$4.56	YC 8 R1/8 K	\$4.12
8 mm	R1/4	MC 8 R1/4 K	\$1.64			ME 8 R1/4 K	\$2.60	BT 8 R1/4 K	\$4.12	RT 8 R1/4 K	\$5.01	YC 8 R1/4 K	\$4.12
8 mm	R3/8	MC 8 R3/8 K	\$2.34			ME 8 R3/8 K	\$2.60	BT 8 R3/8 K	\$4.56	RT 8 R3/8 K	\$5.48	YC 8 R3/8 K	\$4.56
8 mm	R1/2	MC 8 R1/2 K	\$2.34			ME 8 R1/2 K	\$2.96	BT 8 R1/2 K	\$4.56	RT 8 R1/2 K	\$6.36	YC 8 R1/2 K	\$5.83
10 mm	R1/8	MC 10 R1/8 K	\$2.43			ME 10 R1/8 K	\$2.96	BT 10 R1/8 K	\$4.39	RT 10 R1/8 K	\$5.48	YC 10 R1/8 K	\$4.56
10 mm	R1/4	MC 10 R1/4 K	\$2.43			ME 10 R1/4 K	\$2.96	BT 10 R1/4 K	\$4.56	RT 10 R1/4 K	\$5.48	YC 10 R1/4 K	\$4.56
10 mm	R3/8	MC 10 R3/8 K	\$3.49			ME 10 R3/8 K	\$3.71	BT 10 R3/8 K	\$4.90	RT 10 R3/8 K	\$5.83	YC 10 R3/8 K	\$4.84
10 mm	R1/2	MC 10 R1/2 K	\$3.24			ME 10 R1/2 K	\$5.38	BT 10 R1/2 K	\$6.36	RT 10 R1/2 K	\$6.36	YC 10 R1/2 K	\$5.87
12 mm	R1/8	MC 12 R1/8 K	\$2.36										
12 mm	R1/4	MC 12 R1/4 K	\$3.47			ME 12 R1/4 K	\$5.38	BT 12 R1/4 K	\$5.87	RT 12 R1/4 K	\$5.87	YC 12 R1/4 K	\$5.87
12 mm	R3/8	MC 12 R3/8 K	\$3.47			ME 12 R3/8 K	\$5.38	BT 12 R3/8 K	\$5.87	RT 12 R3/8 K	\$6.36	YC 12 R3/8 K	\$5.87
12 mm	R1/2	MC 12 R1/2 K	\$3.55			ME 12 R1/2 K	\$5.38	BT 12 R1/2 K	\$6.36	RT 12 R1/2 K	\$6.79	YC 12 R1/2 K	\$6.36



Composite Push-In Air Fittings List Price

Composite Fittings															
Model		Extended Elbow		Universal Elbow		Female Connector		Female Elbow		Bulkhead Connector		Flow Control Valve (Meter-In Tube)		Flow Control Valve (Meter-Out Tube)	
Tube OD	Pipe Size	EE		UE		FC		FE		BC		CI		CV	
1/8	10-32UNF			UE 1/8 10-32 K	\$3.65	FC 1/8 10-32 K	\$2.05	FE 1/8 10-32 K	\$2.93			CI 1/8 10-32 K	\$10.48	CV 1/8 10-32 K	\$9.02
1/8	NPT1/8			UE 1/8 N1/8 K	\$3.65	FC 1/8 N1/8 K	\$2.05	FE 1/8 N1/8 K	\$2.93	BC 1/8 N1/8 K	\$3.86	CI 1/8 N1/8 K	\$10.48	CV 1/8 N1/8 K	\$9.02
5/32	10-32UNF	EE 5/32 10-32 K	\$2.93	UE 5/32 10-32 K	\$3.65	FC 5/32 10-32 K	\$2.05	FE 5/32 10-32 K	\$2.93			CI 5/32 10-32 K	\$10.48	CV 5/32 10-32 K	\$9.02
5/32	NPT1/8	EE 5/32 N1/8 K	\$2.93	UE 5/32 N1/8 K	\$3.65	FC 5/32 N1/8 K	\$2.05	FE 5/32 N1/8 K	\$2.93	BC 5/32 N1/8 K	\$3.87			CV 5/32 N1/8 K	\$9.02
5/32	NPT1/4					FC 5/32 N1/4 K	\$2.05	FE 5/32 N1/4 K	\$2.93					CV 5/32 N1/4 K	\$9.02
3/16	10-32UNF			UE 3/16 10-32 K	\$4.39										
3/16	NPT1/8	EE 3/16 N1/8 K	\$2.93	UE 3/16 N1/8 K	\$4.39					BC 3/16 N1/8 K	\$3.86			CV 3/16 N1/8 K	\$9.02
3/16	NPT1/4	EE 3/16 N1/4 K	\$2.93	UE 3/16 N1/4 K	\$4.39					BC 3/16 N1/4 K	\$3.86				
3/16	NPT3/8	EE 3/16 N3/8 K	\$3.70												
1/4	10-32UNF			UE 1/4 10-32 K	\$4.39			FE 1/4 10-32 K	\$2.93			CI 1/4 10-32 K	\$10.48	CV 1/4 10-32 K	\$9.02
1/4	NPT1/8	EE 1/4 N1/8 K	\$2.93	UE 1/4 N1/8 K	\$4.39	FC 1/4 N1/8 K	\$2.05	FE 1/4 N1/8 K	\$2.93	BC 1/4 N1/8 K	\$4.63	CI 1/4 N1/8 K	\$11.19	CV 1/4 N1/8 K	\$9.75
1/4	NPT1/4	EE 1/4 N1/4 K	\$2.93	UE 1/4 N1/4 K	\$5.01	FC 1/4 N1/4 K	\$2.44	FE 1/4 N1/4 K	\$3.16	BC 1/4 N1/4 K	\$5.30	CI 1/4 N1/4 K	\$11.19	CV 1/4 N1/4 K	\$9.75
1/4	NPT3/8	EE 1/4 N3/8 K	\$3.70					FE 1/4 N3/8 K	\$3.70					CV 1/4 N3/8 K	\$12.42
5/16	NPT1/8	EE 5/16 N1/8 K	\$3.14	UE 5/16 N1/8 K	\$4.56	FC 5/16 N1/8 K	\$2.34	FE 5/16 N1/8 K	\$3.14	BC 5/16 N1/8 K	\$4.82	CI 5/16 N1/8 K	\$11.19	CV 5/16 N1/8 K	\$9.75
5/16	NPT1/4	EE 5/16 N1/4 K	\$3.14	UE 5/16 N1/4 K	\$4.56	FC 5/16 N1/4 K	\$2.75	FE 5/16 N1/4 K	\$3.16	BC 5/16 N1/4 K	\$5.30			CV 5/16 N1/4 K	\$9.75
5/16	NPT3/8	EE 5/16 N3/8 K	\$3.47	UE 5/16 N3/8 K	\$5.48	FC 5/16 N3/8 K	\$2.78	FE 5/16 N3/8 K	\$3.47					CV 5/16 N3/8 K	\$12.42
3/8	NPT1/8			UE 3/8 N1/8 K	\$5.48			FE 3/8 N1/8 K	\$4.35						
3/8	NPT1/4	EE 3/8 N1/4 K	\$4.35	UE 3/8 N1/4 K	\$5.48	FC 3/8 N1/4 K	\$3.12	FE 3/8 N1/4 K	\$4.35	BC 3/8 N1/4 K	\$5.99	CI 3/8 N1/4 K	\$12.09	CV 3/8 N1/4 K	\$10.63
3/8	NPT3/8	EE 3/8 N3/8 K	\$4.35	UE 3/8 N3/8 K	\$5.87	FC 3/8 N3/8 K	\$4.02	FE 3/8 N3/8 K	\$4.35	BC 3/8 N3/8 K	\$6.33	CI 3/8 N3/8 K	\$13.90	CV 3/8 N3/8 K	\$12.42
3/8	NPT1/2	EE 3/8 N1/2 K	\$6.53			FC 3/8 N1/2 K	\$4.76	FE 3/8 N1/2 K	\$6.53			CI 3/8 N1/2 K	\$16.87	CV 3/8 N1/2 K	\$14.82
1/2	NPT1/4	EE 1/2 N1/4 K	\$6.53	UE 1/2 N1/4 K	\$6.36	FC 1/2 N1/4 K	\$4.76								
1/2	NPT3/8	EE 1/2 N3/8 K	\$6.53	UE 1/2 N3/8 K	\$6.36	FC 1/2 N3/8 K	\$4.76	FE 1/2 N3/8 K	\$6.53	BC 1/2 N3/8 K	\$7.17	CI 1/2 N3/8 K	\$15.66	CV 1/2 N3/8 K	\$14.21
1/2	NPT1/2	EE 1/2 N1/2 K	\$7.79	UE 1/2 N1/2 K	\$6.79			FE 1/2 N1/2 K	\$8.15	BC 1/2 N1/2 K	\$7.17	CI 1/2 N1/2 K	\$16.30	CV 1/2 N1/2 K	\$14.99
4 mm	M5X0.8	EE 4 M5 K	\$2.93	UE 4 M5 K	\$3.65			FE 4 M5 K	\$2.93					CV 4 M5 K	\$9.02
4 mm	M6X1	EE 4 M6 K	\$2.93	UE 4 M6 K	\$3.65			FE 4 M6 K	\$2.93					CV 4 M6 K	\$9.02
4 mm	R1/8	EE 4 R1/8 K	\$2.93	UE 4 R1/8 K	\$3.65	FC 4 R1/8 K	\$2.05	FE 4 R1/8 K	\$2.93	BC 4 R1/8 K	\$3.87			CV 4 R1/8 K	\$9.02
4 mm	R1/4	EE 4 R1/4 K	\$2.93	UE 4 R1/4 K	\$4.39	FC 4 R1/4 K	\$2.05	FE 4 R1/4 K	\$2.93	BC 4 R1/4 K	\$3.87			CV 4 R1/4 K	\$9.75
6 mm	M5X0.8	EE 6 M5 K	\$2.93	UE 6 M5 K	\$4.39			FE 6 M5 K	\$2.93					CV 6 M5 K	\$9.02
6 mm	M6X1	EE 6 M6 K	\$2.93	UE 6 M6 K	\$4.39			FE 6 M6 K	\$2.93					CV 6 M6 K	\$9.02
6 mm	R1/8	EE 6 R1/8 K	\$2.93	UE 6 R1/8 K	\$4.39	FC 6 R1/8 K	\$2.05	FE 6 R1/8 K	\$2.93	BC 6 R1/8 K	\$4.63	CI 6 R1/8 K	\$11.19	CV 6 R1/8 K	\$9.75
6 mm	R1/4	EE 6 R1/4 K	\$2.93	UE 6 R1/4 K	\$5.01	FC 6 R1/4 K	\$2.32	FE 6 R1/4 K	\$2.93	BC 6 R1/4 K	\$5.30			CV 6 R1/4 K	\$9.75
6 mm	R3/8	EE 6 R3/8 K	\$3.70	UE 6 R3/8 K	\$5.48	FC 6 R3/8 K	\$2.78	FE 6 R3/8 K	\$3.70	BC 6 R3/8 K	\$5.79			CV 6 R3/8 K	\$12.42
6 mm	R1/2	EE 6 R1/2 K	\$5.79												
8 mm	R1/8	EE 8 R1/8 K	\$3.14	UE 8 R1/8 K	\$4.56	FC 8 R1/8 K	\$2.34	FE 8 R1/8 K	\$3.14	BC 8 R1/8 K	\$4.82			CV 8 R1/8 K	\$9.75
8 mm	R1/4	EE 8 R1/4 K	\$3.14	UE 8 R1/4 K	\$4.56	FC 8 R1/4 K	\$2.34	FE 8 R1/4 K	\$3.14	BC 8 R1/4 K	\$5.30			CV 8 R1/4 K	\$9.75
8 mm	R3/8	EE 8 R3/8 K	\$3.70	UE 8 R3/8 K	\$5.48	FC 8 R3/8 K	\$2.78	FE 8 R3/8 K	\$3.47	BC 8 R3/8 K	\$5.79	CI 8 R3/8 K	\$14.45	CV 8 R3/8 K	\$12.42
8 mm	R1/2	EE 8 R1/2 K	\$5.79	UE 8 R1/2 K	\$6.36	FC 8 R1/2 K	\$4.56			BC 8 R1/2 K	\$6.69			CV 8 R1/2 K	\$12.42
10 mm	R1/8	EE 10 R1/8 K	\$4.35			FC 10 R1/8 K	\$3.12	FE 10 R1/8 K	\$4.35	BC 10 R1/8 K	\$5.30				
10 mm	R1/4	EE 10 R1/4 K	\$4.35	UE 10 R1/4 K	\$5.48	FC 10 R1/4 K	\$3.12	FE 10 R1/4 K	\$4.35	BC 10 R1/4 K	\$5.79			CV 10 R1/4 K	\$10.63
10 mm	R3/8	EE 10 R3/8 K	\$4.35	UE 10 R3/8 K	\$5.87	FC 10 R3/8 K	\$3.12	FE 10 R3/8 K	\$4.35	BC 10 R3/8 K	\$6.24			CV 10 R3/8 K	\$12.42
10 mm	R1/2	EE 10 R1/2 K	\$6.53	UE 10 R1/2 K	\$6.36	FC 10 R1/2 K	\$4.75	FE 10 R1/2 K	\$6.53	BC 10 R1/2 K	\$6.69			CV 10 R1/2 K	\$14.82
12 mm	R1/4	EE 12 R1/4 K	\$6.53	UE 12 R1/4 K	\$6.36	FC 12 R1/4 K	\$4.75	FE 12 R1/4 K	\$6.53	BC 12 R1/4 K	\$6.24			CV 12 R1/4 K	\$14.21
12 mm	R3/8	EE 12 R3/8 K	\$6.53	UE 12 R3/8 K	\$6.36	FC 12 R3/8 K	\$4.75	FE 12 R3/8 K	\$6.53	BC 12 R3/8 K	\$6.69			CV 12 R3/8 K	\$14.21
12 mm	R1/2	EE 12 R1/2 K	\$6.53	UE 12 R1/2 K	\$6.79	FC 12 R1/2 K	\$4.75	FE 12 R1/2 K	\$6.53	BC 12 R1/2 K	\$7.17			CV 12 R1/2 K	\$14.82

Composite Fittings							
Model	Flow Control Valve (Inline)	Bulkhead Union	Cross Union	Elbow Union	Straight Union	Tee Union	Y Union
Tube OD	FV	BU	CU	EU	SU	TU	YU
1/8	FV 1/8 K \$10.45	BU 1/8 K \$3.81	CU 1/8 K \$4.49	EU 1/8 K \$1.95	SU 1/8 K \$1.95	TU 1/8 K \$2.88	YU 1/8 K \$2.88
5/32	FV 5/32 K \$10.45	BU 5/32 K \$3.81	CU 5/32 K \$4.49	EU 5/32 K \$1.95	SU 5/32 K \$1.95	TU 5/32 K \$2.88	YU 5/32 K \$2.88
3/16	FV 3/16 K \$10.45	BU 3/16 K \$3.81	CU 3/16 K \$4.49	EU 3/16 K \$1.95	SU 3/16 K \$1.95	TU 3/16 K \$2.88	YU 3/16 K \$2.88
1/4	FV 1/4 K \$10.79	BU 1/4 K \$3.81	CU 1/4 K \$4.49	EU 1/4 K \$2.02	SU 1/4 K \$2.02	TU 1/4 K \$2.88	YU 1/4 K \$2.88
5/16	FV 5/16 K \$10.79	BU 5/16 K \$4.60	CU 5/16 K \$4.49	EU 5/16 K \$2.36	SU 5/16 K \$2.32	TU 5/16 K \$2.88	YU 5/16 K \$2.88
3/8	FV 3/8 K \$11.96	BU 3/8 K \$5.56	CU 3/8 K \$5.62	EU 3/8 K \$2.70	SU 3/8 K \$2.70	TU 3/8 K \$3.56	YU 3/8 K \$3.56
1/2	FV 1/2 K \$16.63	BU 1/2 K \$5.72	CU 1/2 K \$6.96	EU 1/2 K \$3.14	SU 1/2 K \$3.12	TU 1/2 K \$4.47	YU 1/2 K \$4.47
4 mm	FV 4 K \$10.79	BU 4 K \$3.81	CU 4 K \$4.49	EU 4 K \$1.95	SU 4 K \$1.95	TU 4 K \$2.88	YU 4 K \$2.87
6 mm	FV 6 K \$10.79	BU 6 K \$3.81	CU 6 K \$4.49	EU 6 K \$2.02	SU 6 K \$2.02	TU 6 K \$2.88	YU 6 K \$2.87
8 mm	FV 08 K \$10.91	BU 8 K \$4.60	CU 8 K \$5.62	EU 8 K \$2.36	SU 8 K \$2.32	TU 8 K \$2.88	YU 8 K \$2.87
10 mm	FV 10 K \$15.76	BU 10 K \$5.56	CU 10 K \$6.64	EU 10 K \$2.70	SU 10 K \$2.70	TU 10 K \$3.56	YU 10 K \$3.56
12 mm	FV 12 K \$17.52	BU 12 K \$5.72	CU 12 K \$6.96	EU 12 K \$2.94	SU 12 K \$3.14	TU 12 K \$4.47	YU 12 K \$4.47

Composite Fittings							
Model	Elbow Reducer (Tube-Stem)	Plug In Elbow	Male Manifold	Manifold Union	Reduced Branch	Reduced Union	Tee Union Reducer
Tube OD	ER	PE	MM	MU	RB	RU	TU
1/8							
5/32	ER 1/4-5/32 K \$3.75	PE 5/32 K \$3.75		MU 5/32X1/8 K \$5.80	RB 5/32-1/8 K \$3.75	RU 5/32-1/8 K \$2.32	
3/16					RB 3/16-5/32 K \$3.56	RU 3/16-5/32 K \$2.32	
1/4	ER 5/16-1/4 K \$3.75 ER 3/8-1/4 K \$2.66	PE 1/4 K \$3.75	MM 1/4-5/32-N1/8 \$6.43	MU 1/4x1/8 K \$5.80 MU 1/4x5/32 K \$5.80	RB 1/4-5/32 K \$3.75 RB 1/4-3/16 K \$3.75	RU 1/4-5/32 K \$2.32 RU 1/4-3/16 K \$2.70	TU 1/4-5/32 K \$3.75
5/16		PE 5/16 K \$3.75	MM 5/16-5/32-N1/4 \$6.59 MM 5/16-1/4-N1/4 \$6.59	MU 5/16X5/32 K \$5.80 MU 5/16X1/4 K \$5.80	RB 5/16-1/4 K \$3.75	RU 5/16-1/4 K \$2.70	TU 5/16-1/4 K \$3.75
3/8		PE 3/8 K \$6.64		MU 3/8X1/4 K \$8.04	RB 3/8-1/4 K \$4.47 RB 3/8-5/16 K \$4.47	RU 3/8-1/4 K \$3.12 RU 3/8-5/16 K \$3.12	TU 3/8-1/4 K \$4.47 TU 3/8-5/16 K \$4.47
1/2		PE 1/2 K \$6.64			RB 1/2-3/8 K \$5.35	RU 1/2-3/8 K \$3.56	TU 1/2-3/8 K \$5.34
4 mm	ER 6-4 K \$3.75						
6 mm	ER 8-6 K \$3.75	PE 6 K \$3.04	MM 6-4-R1/8 \$6.59	MU 06-04 K \$5.80	RB 6-4 K \$3.75	RU 6-4 K \$2.32	TU 6-4 K \$3.75
8 mm	ER 10-8 K \$4.47		MM 8-4-R1/4 \$6.59 MM 8-6-R1/4 \$8.53	MU 08-04 K \$5.80 MU 08-06 K \$6.59	RB 8-6 K \$3.75	RU 8-6 K \$2.70	TU 8-6 K \$3.75
10 mm	ER 12-10 K \$5.34		MM 10-8-R3/8 \$9.01	MU 10-6 K \$7.55 MU 10-8 K \$7.55	RB 10-8 K \$4.47	RU 10-6 K \$3.14 RU 10-8 K \$3.14	TU 10-8 K \$4.47
12 mm					RB 12-10 K \$5.35	RU 12-10 K \$3.56	TU 12-10 K \$5.34

Composite Fittings								
Model	Plug	Stem Coupler	Stem Reducer	Tube Reducer (Tube-Stem)	Y Reducer (Tube Stem)	Model	Stack Elbow	Male Angle
Tube OD	PG	SC	SR	TR	YR	Tube OD Pipe Size	SE	MA
1/8	PG 1/8 \$0.80					1/8 10-32		MA 1/8 10-32 \$2.59
5/32	PG 5/32 \$0.80	SC 5/32 \$0.95	SR 5/32-1/4 \$1.27	TR 5/32-1/4 \$2.45	YR 5/32-1/4 \$3.33	1/8 NPT1/8	SE 1/8 N1/8 K \$5.63	MA 1/8 N1/8 \$2.59
3/16	PG 3/16 \$0.80					5/32 10-32	SE 5/32 10-32 K \$5.63	MA 5/32 10-32 \$2.59
1/4	PG 1/4 \$0.80	SC 1/4 \$0.95	SR 1/4-5/16 \$1.62	TR 1/4-5/16 \$2.89	YR 1/4-5/16 \$6.18	5/32 NPT1/8	SE 5/32 N1/8 K \$5.63	MA 5/32 N1/8 \$2.59
1/4				TR 1/4-3/8 \$2.89		5/32 NPT1/4	SE 5/32 N1/4 K \$5.63	MA 5/32 N1/4 \$2.59
5/16	PG 5/16 \$0.95	SC 5/16 \$1.27	SR 5/16-3/8 \$1.62	TR 5/16-3/8 \$4.06	YR 5/16-3/8 \$8.43	1/4 NPT1/8	SE 1/4 N1/8 K \$5.01	MA 1/4 N1/8 \$2.59
3/8	PG 3/8 \$0.95	SC 3/8 \$1.27	SR 3/8-1/2 \$1.62	TR 3/8-1/2 \$3.89		1/4 NPT1/4	SE 1/4 N1/4 K \$5.68	MA 1/4 N1/4 \$2.59
1/2	PG 1/2 \$1.18	SC 1/2 \$1.37				1/4 NPT3/8	SE 1/4 N3/8 K \$5.68	MA1/4 N3/8 \$3.24
4 mm	PG 4 \$0.80	SC 4 \$0.95				5/16 NPT1/4	SE 5/16 N1/4 K \$6.02	MA 5/16 N1/4 \$2.12
6 mm	PG 6 \$0.80	SC 6 \$0.95	SR 4-6 \$1.62	TR 4-6 \$2.45		5/16 NPT3/8	SE 5/16 N3/8 K \$6.02	
8 mm	PG 8 \$0.95	SC 8 \$1.27	SR 6-8 \$1.27	TR 6-8 \$2.89		3/8 NPT1/8	SE 3/8 N1/8 K \$6.02	MA 3/8 N1/8 \$3.24
10 mm	PG10 \$0.95	SC10 \$1.27	SR 8-10 \$1.62	TR 8-10 \$2.89		3/8 NPT1/4	SE 3/8 N1/4 K \$6.02	MA 3/8 N1/4 \$3.24
12 mm	PG 12 \$0.95	SC 12 \$1.27		TR 10-12 \$3.89		3/8 NPT3/8	SE 3/8 N3/8 K \$6.02	MA 3/8 N3/8 \$3.55
						1/2 NPT3/8	SE 1/2 N3/8 K \$6.38	
						1/2 NPT1/2	SE 1/2 N1/2 K \$6.78	

A. Installation of Pipe Fittings:

1. Tighten fitting by hand, then turn it 2-3 turns with a wrench until it reaches the desired torque listed. If the fittings are not pre-coated with sealant, or is used and the sealant is not in good condition, apply Teflon sealant tape to the threads.

Recommendation of Torque for Tightening Fittings		
Fitting Thread Size	Torque, lb-ft	Torque, kgf/cm
10-32, M5 –M6	1.0 – 1.5	14 – 21
NPT1/8, R1/8	5 – 6.5	70 – 90
NPT1/4, R1/4	8.5 – 10	120 – 140
NPT3/8, R3/8	16 – 17.5	220 – 240
NPT1/2, R1/2	20 – 21.5	280 – 300

B. Installation of Tubing into Fitting:

1. Slowly push a clean and perpendicularly cut tube into the fitting until it comes to a dead stop.
2. Gently pull the tubing back until the Grip Ring or Collet of the fitting grips onto the tubing and has a good seal.
3. Use Polyethylene, Polypropylene, Polyurethane, or Nylon tubing designed for instant fittings.

C. Removal of Tubing from Fitting:

1. Push in on the two long, oval sides of the Release Button.
2. Pull out the tube while depressing the Release Button.
3. To reuse the tubing, cut off the lodged portion of the previously used tubing in an even and perpendicular fashion.

D. Recommended Tubing Material, Size, and Hardness Requirements:

Tubing Material	Specified Size	Hardness (Durometer)
Polyurethane	+/- 0.006" (+/-0.15 mm)	Shore A 85 or higher
Polyethylene	+/- 0.004" (+/-0.1 mm)	Shore D 44—D75
Polypropylene	+/- 0.004" (+/-0.1 mm)	Shore D 44—D75
Nylon	+/- 0.004" (+/-0.1 mm)	Shore D 44—D75
Pre-grooved Metal Tubing	+/- 0.004" (+/-0.1 mm)	

E. Specifications, Materials of Construction, and Schematic of Typical Construction:

Specifications	
Operating Pressure Range	0 - 180 PSI (0 - 1200 kpa)
Vacuum	0 - 29.5" Hg (750 mm Hg)
Operating Temperature	32 - 140°F (0 - 60 °C)
Recommended Tubing Material	Polyurethane, Nylon, Polyethylene, Polypropylene
Metal Body	Brass, Nickel Plated
Plastic Body	PBT (Polybutylene terephthalate)
Release Button	POM (Poly oxy methylene copolymer)
Grip Ring or Collet	300 series Stainless Steel
O-ring	NBR (Buna-N)
Thread Sealant	Teflon
Service	FOR AIR ONLY

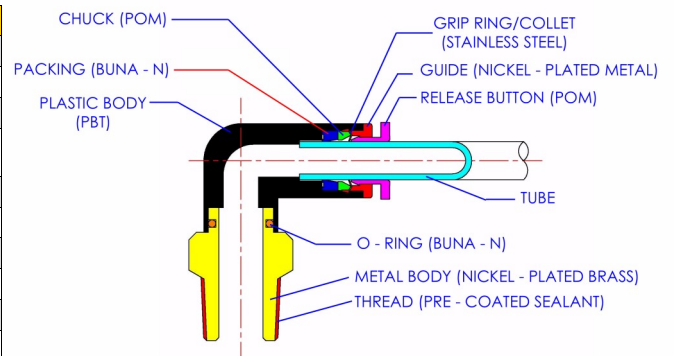

SCHEMATIC OF TYPICAL COMPOSITE FITTING CONSTRUCTION

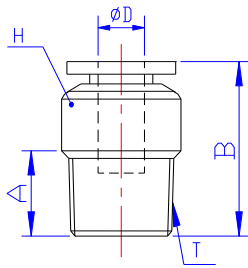

Compact Male Connector (CC)

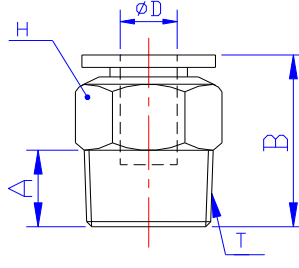

Male Connector (MC)

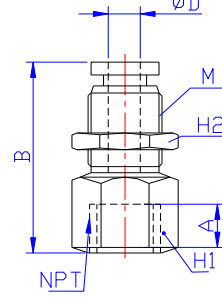

Bulkhead Connector (BC)

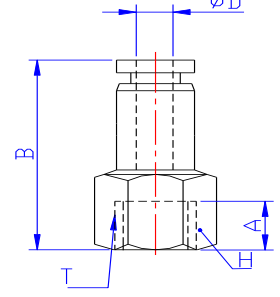

Female Connector (FC)

Model		Compact Male Connector				Male Connector				Bulkhead Connector					Female Connector				
		CC				MC				BC					FC				
ØD	T	Part No.	A	B	H	Part No.	A	B	H	Part No.	M	A	H1	H2	B	Part No.	A	B	H
5/32	10-32UNF	CC 5/32 10-32	3.8	20.3	Ø10	MC 5/32 10-32	3.8	20.3	11.1										
5/32	NPT1/8	CC 5/32 N1/8	7.5	19.8	Ø10	MC 5/32 N1/8	7.5	19.8	11.1	BC 5/32 N1/8	M12	7.5	14.3	14.3	23.8	FC 5/32 N1/8	7.5	23.8	14.3
5/32	NPT1/4	CC 5/32 N1/4				MC 5/32 N1/4	10.5	18.9	14.3							FC 5/32 N1/4	10.5	26.8	17.4
3/16	10-32UNF	CC 3/16 10-32				MC 3/16 10-32	3.8	20.9	11.1										
3/16	NPT1/8	CC 3/16 N1/8				MC 3/16 N1/8	7.5	20.6	11.1	BC 3/16 N1/8	M14	7.5	14.3	17.4	24.7	FC 3/16 N1/8	7.5	24.4	14.3
3/16	NPT1/4	CC 3/16 N1/4				MC 3/16 N1/4	10.5	23.7	14.3	BC 3/16 N1/4	M14	10.5	14.3	17.4	30.4	FC 3/16 N1/4	10.5	27.4	17.4
3/16	NPT3/8	CC 3/16 N3/8				MC 3/16 N3/8	11	21.2	17.4										
1/4	10-32UNF	CC 1/4 10-32	3.8	21.2	Ø12	MC 1/4 10-32	3.8	21.2	12.7										
1/4	NPT1/8	CC 1/4 N1/8	7.5	20.9	Ø12	MC 1/4 N1/8	7.5	20.9	12.7	BC 1/4 N1/8	M14	7.5	17.4	17.4	24.7	FC 1/4 N1/8	7.5	24.9	14.3
1/4	NPT1/4	CC 1/4 N1/4	10.5	23.7	Ø14	MC 1/4 N1/4	10.5	23.7	14.3	BC 1/4 N1/4	M14	10.5	17.4	17.4	30.4	FC 1/4 N1/4	10.5	27.9	17.4
1/4	NPT3/8	CC 1/4 N3/8				MC 1/4 N3/8	11	21.2	17.4										
5/16	NPT1/8	CC 5/16 N1/8	7.5	25.9	Ø14	MC 5/16 N1/8	7.5	25.9	14.3	BC 5/16 N1/8	M16	7.5	17.4	19	27.9	FC 5/16 N1/8	7.5	26.4	14.3
5/16	NPT1/4	CC 5/16 N1/4	10.5	25.9	Ø14	MC 5/16 N1/4	10.5	25.9	14.3	BC 5/16 N1/4	M16	10.5	19	19	35.9	FC 5/16 N1/4	10.5	29.4	17.4
5/16	NPT3/8	CC 5/16 N3/8	11	22.4	Ø17	MC 5/16 N3/8	11	22.4	17.4	BC 5/16 N3/8	M16	11	19	19	35.4	FC 5/16 N3/8	11	29.9	22.2
3/8	NPT1/8	CC 3/8 N1/8				MC 3/8 N1/8	7.5	28.2	17.4										
3/8	NPT1/4	CC 3/8 N1/4	10.5	30.5	Ø17	MC 3/8 N1/4	10.5	30.5	17.4	BC 3/8 N1/4	M20	10.5	22.2	22.2	31.9	FC 3/8 N1/4	10.5	31.2	17.4
3/8	NPT3/8	CC 3/8 N3/8	11	27.5	Ø17	MC 3/8 N3/8	11	27.5	17.4	BC 3/8 N3/8	M20	11	22.2	22.2	34.7	FC 3/8 N3/8	11	31.7	22.2
3/8	NPT1/2	CC 3/8 N1/2	14	25.8	Ø21	MC 3/8 N1/2	14	25.8	22.2										
1/2	NPT1/4	CC 1/2 N1/4	10.5	33.9	Ø21	MC 1/2 N1/4	10.5	33.9	22.2							FC 1/2 N1/4	10.5	34.4	22.2
1/2	NPT3/8	CC 1/2 N3/8	11	30.4	Ø21	MC 1/2 N3/8	11	30.4	22.2	BC 1/2 N3/8	M22	11	25.4	25.4	35.4	FC 1/2 N3/8	11	34.9	22.2
1/2	NPT1/2	CC 1/2 N1/2	14	33.4	Ø21	MC 1/2 N1/2	14	33.4	22.2	BC 1/2 N1/2	M22	14	25.4	25.4	41.4				

ØD	T	Part No.	A	B	H	Part No.	A	B	H	Part No.	M	A	H1	H2	B	Part No.	A	B	H
4	M5	CC 4 M5	3.8	20.1	Ø10	MC 4 M5	3.8	20.1	10										
4	M6	CC 4 M6	4.5	20.8	Ø10	MC 4 M6	4.5	20.8	10										
4	R1/8	CC 4 R1/8	7	19.3	Ø10	MC 4 R1/8	7	19.3	10	BC 4 R1/8	M12	7	14	14	23.3	FC 4 1/8	7	22.3	14
4	R1/4	CC 4 R1/4	9.5	17.9	Ø14	MC 4 R1/4	9.5	17.9	14	BC 4 R1/4	M12	9	17	14	25.4	FC 4 R1/4	9	25.3	17
6	M5	CC 6 M5	3.8	21	Ø12	MC 6 M5	3.8	21.2	12										
6	M6	CC 6 M6	4.5	21.7	Ø12	MC 6 M6	4.5	21.7	12										
6	R1/8	CC 6 R1/8	7	20.4	Ø12	MC 6 R1/8	7	20.4	12	BC 6 R1/8	M14	7	17	17	24.2	FC 6 R1/8	7	24.4	14
6	R1/4	CC 6 R1/4	9.5	22.7	Ø14	MC 6 R1/4	9.5	22.7	14	BC 6 R1/4	M14	9	17	17	29.2	FC 6 R1/4	9	26.4	17
6	R3/8	CC 6 R3/8	10.5	20.7	Ø17	MC 6 R3/8	10.5	20.7	17	BC 6 R3/8	M14	10	19	17	30.2	FC 6 R3/8	10	27.4	19
6	R1/2					MC 6 R1/2	13.5	24.7	21										
8	R1/8	CC 8 R1/8	7	25.4	Ø14	MC 8 R1/8	7	25.4	14	BC 8 R1/8	M16	7	19	19	27.4	FC 8 R1/8	7	25.9	14
8	R1/4	CC 8 R1/4	9.5	24.9	Ø14	MC 8 R1/4	9.5	24.9	14	BC 8 R1/4	M16	9	19	19	34.4	FC 8 R1/4	9	27.9	17
8	R3/8	CC 8 R3/8	10.5	21.9	Ø17	MC 8 R3/8	10.5	21.9	17	BC 8 R3/8	M16	10	19	19	34.4	FC 8 R3/8	10	28.9	19
8	R1/2	CC 8 R1/2	13.5	25.9	Ø21	MC 8 R1/2	13.5	25.9	21	BC 8 R1/2	M16	12	24	19	36.4	FC 8 R1/2	12	30.9	24
10	R1/8	CC 10 R1/8	7	27.7	Ø17	MC 10 R1/8	7	27.7	17	BC 10 R1/8	M20	7	21	24	28.4	FC 10 R1/8	7	27.7	17
10	R1/4	CC 10 R1/4	9.5	29.5	Ø17	MC 10 R1/4	9.5	29.5	17	BC 10 R1/4	M20	9	21	24	30.4	FC 10 R1/4	9	29.7	17
10	R3/8	CC 10 R3/8	10.5	27	Ø17	MC 10 R3/8	10.5	27	17	BC 10 R3/8	M20	10	21	24	33.7	FC 10 R3/8	10	30.7	19
10	R1/2	CC 10 R1/2	13.5	25.3	Ø21	MC 10 R1/2	13.5	25.3	21	BC 10 R1/2	M20	12	24	24	35.7	FC 10 R1/2	12	32.7	24
12	R1/4	CC 12 R1/4	9.5	32.9	Ø20	MC 12 R1/4	9.5	32.9	20	BC 12 R1/4	M22	9	24	27	33.5	FC 12 R1/4	9	32.9	20
12	R3/8	CC 12 R3/8	10.5	29.9	Ø20	MC 12 R3/8	10.5	29.9	20	BC 12 R3/8	M22	10	24	27	34.4	FC 12 R3/8	10	33.9	20
12	R1/2	CC 12 R1/2	13.5	32.9	Ø21	MC 12 R1/2	13.5	32.9	21	BC 12 R1/2	M22	12	24	27	39.4	FC 12 R1/2	12	35.9	24

Units in mm

Composite Push-In Air Fittings Dimensions

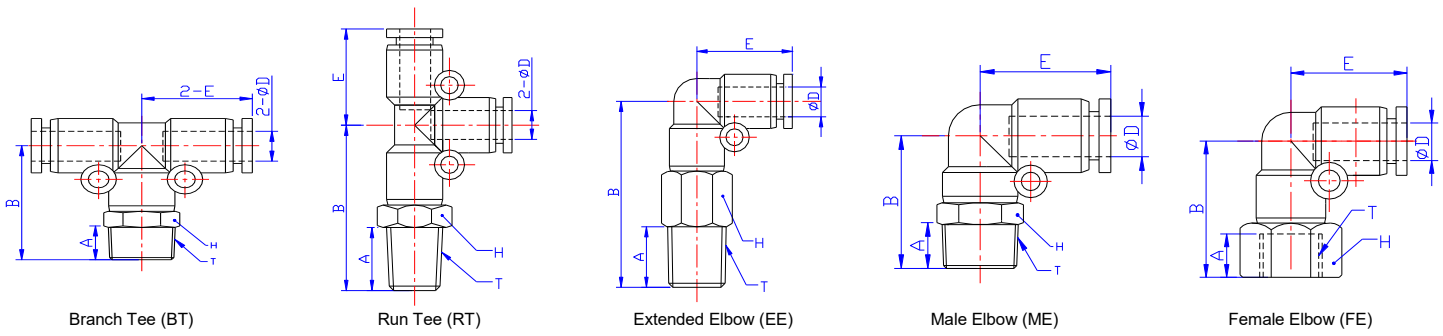

Model	Branch Tee & Run Tee							Extended Elbow				Male Elbow				Female Elbow					
	BT / RT		BT / RT		A	B	E	H	EE		A	B	E	H	ME		A	B	E	H	
5/32 10-32UNF	BT 5/32 10-32	RT 5/32 10-32	3.8	23	18.5	11.1	EE5/32 10-32	3.8	33.5	17.5	11.1	ME 5/32 10-32	3.8	22	17.5	11.1	FE 5/32 10-32				
5/32 NPT1/8	BT 5/32 N1/8	RT 5/32 N1/8	7.5	25	18.5	11.1	EE 5/32 N1/8	7.5	36	17.5	11.1	ME 5/32 N1/8	7.5	24	17.5	11.1	FE 5/32 N1/8	7.5	23.5	17.5	14.3
5/32 NPT1/4	BT 5/32 N1/4	RT 5/32 N1/4	10.5	29	18.5	14.3						ME 5/32 N1/4	10.5	28	17.5	14.3	FE 5/32 N1/4				
3/16 10-32UNF	BT 3/16 10-32	RT 3/16 10-32	3.8	23	18.8	11.1						ME 3/16 10-32	3.8	22	17.8	11.1	FE 3/16 10-32				
3/16 NPT1/8	BT 3/16 N1/8	RT 3/16 N1/8	7.5	25.5	18.8	11.1	EE 3/16 N1/8		36	17.8	11.1	ME 3/16 N1/8	7.5	24.5	17.8	11.1	FE 3/16 N1/8	7.5	23.8	17.8	14.3
3/16 NPT1/4	BT 3/16 N1/4	RT 3/16 N1/4	10.5	29	18.8	14.3	EE 3/16 N1/4	10.5	39.5	17.8	14.3	ME 3/16 N1/4	10.5	28	17.8	14.3	FE 3/16 N1/4	10.5	26.5	17.8	17.4
3/16 NPT3/8	BT 3/16 N3/8	RT 3/16 N3/8	11	30	18.8	17.4	EE 3/16 N3/8	11	40.5	17.8	17.4	ME 3/16 N3/8	11	29	17.8	17.4					
1/4 10-32UNF	BT 1/4 10-32	RT 1/4 10-32	3.8	24.7	19.3	12.7						ME 1/4 10-32	3.8	24.4	19	12.7	FE 1/4 10-32				
1/4 NPT1/8	BT 1/4 N1/8	RT 1/4 N1/8	7.5	26	19.3	12.7	EE 1/4 N1/8	7.5	39.7	19	12.7	ME 1/4 N1/8	7.5	25.7	19	12.7	FE 1/4 N1/8	7.5	24.9	19	14.3
1/4 NPT1/4	BT 1/4 N1/4	RT 1/4 N1/4	10.5	29.5	19.3	14.3	EE 1/4 N1/4	10.5	43.2	19	14.3	ME 1/4 N1/4	10.5	29.2	19	14.3	FE 1/4 N1/4	10.5	27.9	19	17.4
1/4 NPT3/8	BT 1/4 N3/8	RT 1/4 N3/8	11	30.5	19.3	17.4	EE 1/4 N3/8	11	44.2	19	17.4	ME 1/4 N3/8	11	30.2	19	17.4	FE 1/4 N3/8				
5/16 NPT1/8	BT 5/16 N1/8	RT 5/16 N1/8	7.5	29.45	22.75	14.3	EE 5/16 N1/8	7.5	42.2	22.8	14.3	ME 5/16 N1/8	7.5	27	22.8	14.3	FE 5/16 N1/8	7.5	25	22.8	14.3
5/16 NPT1/4	BT 5/16 N1/4	RT 5/16 N1/4	10.5	32.45	22.75	14.3	EE 5/16 N1/4	10.5	45.3	22.8	14.3	ME 5/16 N1/4	10.5	30	22.8	14.3	FE 5/16 N1/4	10.5	28.5	22.8	17.4
5/16 NPT3/8	BT 5/16 N3/8	RT 5/16 N3/8	11	33.45	22.75	17.4	EE 5/16 N3/8	11	46.3	22.8	17.4	ME 5/16 N3/8	11	31	22.8	17.4	FE 5/16 N3/8	11	29.5	22.8	22.2
3/8 NPT1/8	BT 3/8 N1/8	RT 3/8 N1/8	7.5	35	27	17.4						ME 3/8 N1/8	7.5	30	26.3	17.4					
3/8 NPT1/4	BT 3/8 N1/4	RT 3/8 N1/4	10.5	38	27	17.4	EE 3/8 N1/4	10.5	52	26.3	17.4	ME 3/8 N1/4	10.5	33	26.3	17.4	FE 3/8 N1/4	10.5	31	26.3	17.4
3/8 NPT3/8	BT 3/8 N3/8	RT 3/8 N3/8	11	38.5	27	17.4	EE 3/8 N3/8	11	53.5	26.3	17.4	ME 3/8 N3/8	11	33.5	26.3	17.4	FE 3/8 N3/8	11	31.5	26.3	22.2
3/8 NPT1/2	BT 3/8 N1/2	RT 3/8 N1/2	14	42	27	22.2	EE 3/8 N1/2	14	57	26.3	22.2	ME 3/8 N1/2	14	37	26.3	22.2	FE 3/8 N1/2				
1/2 NPT1/4	BT 1/2 N1/4	RT 1/2 N1/4	10.5	39.5	29.6	22.2	EE 1/2 N1/4	10.5	59.5	29.6	22.2	ME 1/2 N1/4	10.5	36.5	29.6	22.2					
1/2 NPT3/8	BT 1/2 N3/8	RT 1/2 N3/8	11	40	29.6	22.2	EE 1/2 N3/8	11	60	29.6	22.2	ME 1/2 N3/8	11	37	29.6	22.2	FE 1/2-N3/8	11	34.5	29.6	22.2
1/2 NPT1/2	BT 1/2 N1/2	RT 1/2 N1/2	14	43	29.6	22.2	EE 1/2 N1/2	14	63	29.6	22.2	ME 1/2 N1/2	14	40	29.6	22.2	FE 1/2-N1/2	14	37.5	29.6	25.4

ΦD	Pipe Size	Part No.	Part No.	A	B	E	H	Part No.	A	B	E	H	Part No.	A	B	E	H	Part No.	A	B	E	H
4	M5	BT 4 M5	RT 4 M5	3.8	22.3	18.5	10	EE 4 M5	3.8	29.3	17.5	8	ME 4 M5	3.8	17.3	17.5	8	FE 4 M5	4.5	19.5	17.5	10
4	M6	BT 4 M6	RT 4 M6	4.5	23	18.5	10	EE 4 M6	4.5	30	17.5	8	ME 4 M6	4.5	18	17.5	8	FE 4 M6	5	20	17.5	10
4	R1/8	BT 4 R1/8	RT 4 R1/8	7	24.5	18.5	10	EE 4 R1/8	7	35.5	17.5	10	ME 4 R1/8	7	23.5	17.5	10	FE 4 R1/8	7	23	17.5	14
4	R1/4	BT 4 R1/4	RT 4 R1/4	9.5	28	18.5	14	EE 4 R1/4	9.5	39	17.5	14	ME 4 R1/4	9.5	27	17.5	14	FE 4 R1/4	9	25	17.5	17
6	M5	BT 6 M5	RT 6 M5	3.8	23.3	19.3	12	EE 6 M5	3.8	31.3	19	8	ME 6 M5	3.8	17.3	19	8	FE 6 M5	4.5	20.7	19	12
6	M6	BT 6 M6	RT 6 M6	4.5	24	19.3	12	EE 6 M6	4.5	32	19	8	ME 6 M6	4.5	18	19	8	FE 6 M6	5	21.2	19	12
6	R1/8	BT 6 R1/8	RT 6 R1/8	7	25.5	19.3	12	EE 6 R1/8	7	39.2	19	12	ME 6 R1/8	7	25.2	19	12	FE 6 R1/8	7	24.4	19	14
6	R1/4	BT 6 R1/4	RT 6 R1/4	9.5	28.5	19.3	14	EE 6 R1/4	9.5	42.2	19	14	ME 6 R1/4	9.5	28.2	19	14	FE 6 R1/4	9	26.4	19	17
6	R3/8	BT 6 R3/8	RT 6 R3/8	10.5	30	19.3	17	EE 6 R3/8	10.5	43.7	19	17	ME 6 R3/8	10.5	29.7	19	17	FE 6 R3/8	10	27.7	19	19
6	R1/2	BT 6 R1/2	RT 6 R1/2	13.5	33.5	19.3	21	EE 6 R1/2	13.5	47.2	19	21	ME 6 R1/2	13.5	33.2	19	21					
8	R1/8	BT 8 R1/8	RT 8 R1/8	7	29	22.75	14	EE 8 R1/8	7	41.8	22.8	14	ME 8 R1/8	7	26.5	22.8	14	FE 8 R1/8	7	24.8	22.8	14
8	R1/4	BT 8 R1/4	RT 8 R1/4	9.5	31.45	22.75	14	EE 8 R1/4	9.5	44.3	22.8	14	ME 8 R1/4	9.5	29	22.8	14	FE 8 R1/4	9	27	22.8	17
8	R3/8	BT 8 R3/8	RT 8 R3/8	10.5	32.95	22.75	17	EE 8 R3/8	10.5	45.8	22.8	17	ME 8 R3/8	10.5	30.5	22.8	17	FE 8 R3/8	10	28.5	22.8	19
8	R1/2	BT 8 R1/2	RT 8 R1/2	13.5	36.45	22.75	21	EE 8 R1/2	13.5	49.3	22.8	21	ME 8 R1/2	13.5	34	22.8	21	FE 8 R1/2	12	30.5	22.8	24
10	R1/8	BT 10 R1/8	RT 10 R1/8	7	34.5	27	17	EE 10 R1/8	7	49.5	26.3	17	ME 10 R1/8	7	29.5	26.3	17	FE 10 R1/8	7	23	26.3	17
10	R1/4	BT 10 R1/4	RT 10 R1/4	9.5	37	27	17	EE 10 R1/4	9.5	52	26.3	17	ME 10 R1/4	9.5	32	26.3	17	FE 10 R1/4	9	29.5	26.3	17
10	R3/8	BT 10 R3/8	RT 10 R3/8	10.5	38	27	17	EE 10 R3/8	10.5	53	26.3	17	ME 10 R3/8	10.5	33	26.3	17	FE 10 R3/8	10	31	26.3	19
10	R1/2	BT 10 R1/2	RT 10 R1/2	13.5	41.5	27	21	EE 10 R1/2	13.5	56.5	26.3	21	ME 10 R1/2	13.5	36.5	26.3	21	FE 10 R1/2	12	33.5	26.3	24
12	R1/4	BT 12 R1/4	RT 12 R1/4	9.5	38.5	29.6	20	EE 12 R1/4	9.5	58.5	29.6	20	ME 12 R1/4	9.5	36.5	29.6	20	FE 12 R1/4	9	26	29.6	21
12	R3/8	BT 12 R3/8	RT 12 R3/8	10.5	39.5	29.6	20	EE 12 R3/8	10.5	59.5	29.6	20	ME 12 R3/8	10.5	36.5	29.6	20	FE 12 R3/8	10	34	29.6	21
12	R1/2	BT 12 R1/2	RT 12 R1/2	13.5	42.5	29.6	21	EE 12 R1/2	13.5	62.5	29.6	21	ME 12 R1/2	13.5	39.5	29.6	21	FE 12 R1/2	12	36.5	29.6	24

Units in mm

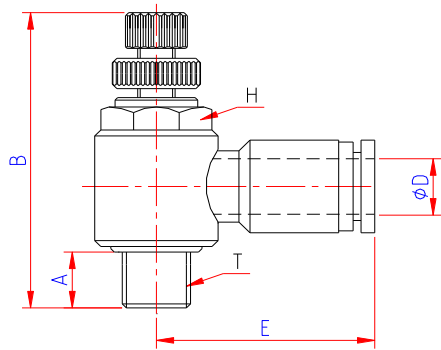

CI = Air Control Valve (Meter-In)
CV = Air Control Valve (Meter-Out)

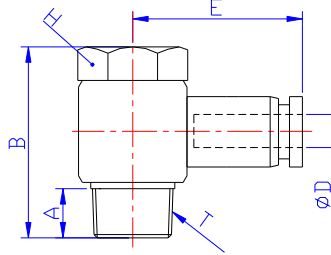

Universal Elbow (UE)

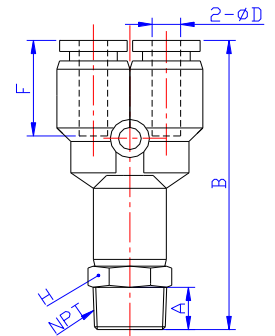

Y Connector (YC)

Model		Control Valve (Meter-In & Meter-Out)			Universal Elbow		Y Connector						
		CI / CV			UE		YC						
ØD	T	A	E	H	Part No. (CI/CV)	B	Part No.	B	Part No.	A	B	F	H
5/32	10-32	3.8	20	8	CV 5/32 10-32	29.3	UE 5/32 10-32	17.8	YC 5/32 10-32	3.8	40	14	11.1
5/32	NPT1/8	7.5	22.6	11.1	CV 5/32 N1/8	40.1	UE 5/32 N1/8	23.5	YC 5/32 N1/8	7.5	42	14	11.1
5/32	NPT1/4								YC 5/32 N1/4	10.5	46	14	14.3
3/16	10-32	3.8	20.3	8			UE 3/16 10-32	17.8	YC 3/16 10-32	3.8	40.3	14.3	11.1
3/16	NPT1/8	7.5	22.6	11.1			UE 3/16 N1/8	23.5	YC 3/16 N1/8	7.5	42.8	14.3	11.1
3/16	NPT1/4	10.5	24.3	14.3			UE 3/16 N1/4	27.3	YC 3/16 N1/4	10.5	46.3	14.3	14.3
3/16	NPT3/8								YC 3/16 N3/8	11	47.3	14.3	17.4
1/4	10-32	3.8	22	8	CV 1/4 10-32	29.3			YC 1/4 10-32	3.8	42.5	14.8	12.7
1/4	NPT1/8	7.5	23.1	11.1	CV 1/4 N1/8	40.1	UE 1/4 N1/8	23.5	YC 1/4 N1/8	7.5	43.8	14.8	12.7
1/4	NPT1/4	10.5	25.1	14.3	CV 1/4 N1/4	47.2	UE 1/4 N1/4	27.3	YC 1/4 N1/4	10.5	47.3	14.8	14.3
1/4	NPT3/8	11	26.8	19	CV 1/4 N3/8	53.9			YC 1/4 N3/8	11	48.3	14.8	17.4
5/16	NPT1/8	7.5	25.6	11.1	CV 5/16 N1/8	40.1	UE 5/16 N1/8	23.5	YC 5/16 N1/8	7.5	47.1	18.2	14.3
5/16	NPT1/4	10.5	28.6	14.3	CV 5/16 N1/4	47.2	UE 5/16 N1/4	27.3	YC 5/16 N1/4	10.5	50.1	18.2	14.3
5/16	NPT3/8	11	29.6	19	CV 5/16 N3/8	53.9	UE 5/16 N3/8	32.4	YC 5/16 N3/8	11	51.1	18.2	17.4
3/8	NPT1/8								YC 3/8 N1/8	7.5	55.1	19.5	17.4
3/8	NPT1/4	10.5	31	14.3	CV 3/8 N1/4	47.2	UE 3/8 N1/4	27.3	YC 3/8 N1/4	10.5	58.1	19.5	17.4
3/8	NPT3/8	11	31.6	19	CV 3/8 N3/8	53.9	UE 3/8 N3/8	32.4	YC 3/8 N3/8	11	58.6	19.5	17.4
3/8	NPT1/2	14	34.6	25.4	CV 3/8 N1/2	58.4			YC 3/8 N1/2	14	62.1	19.5	22.2
1/2	NPT1/4								YC 1/2 N1/4	10.5	63.1	21.6	22.2
1/2	NPT3/8	11	35.6	19	CV 1/2 N3/8	53.9	UE 1/2 N3/8	32.4	YC 1/2 N3/8	11	63.6	21.6	22.2
1/2	NPT1/2	14	36.6	25.4	CV 1/2 N1/2	58.4	UE 1/2 N1/2	39.1	YC 1/2 N1/2	14	66.6	21.6	22.2

ØD	T	A	E	H	Part No. (CV/CI)	B	Part No.	B	Part No.	A	B	F	H
4	M5	4	20	8	CV 4 M5	29.3	UE 4 M5	18	YC 4 M5	3.8	39.3	14	10
4	M6	4.5					UE 4 M6	18.5	YC 4 M6	4.5	40	14	10
4	R1/8	7	22.3	10	CV 4 R1/8	39.7	UE 4 R1/8	23	YC 4 1/8	7	41.5	14	10
4	R1/4	9.5	24.1	14	CV 4 R1/4	46.4	UE 4 R1/4	26.3	YC 4 R1/4	9.5	45	14	14
6	M5	4	21.9	8	CV 6 M5	29.3	UE 6 M5	18	YC 6 M5	3.8	41.1	14.8	12
6	M6	4.5					UE 6 M6	18.5	YC 6 M6	4.5	41.8	14.8	12
6	R1/8	7	23.1	10	CV 6 R1/8	39.7	UE 6 R1/8	23	YC 6 R1/8	7	43.3	14.8	12
6	R1/4	9.5	25.1	14	CV 6 R1/4	46.4	UE 6 R1/4	26.3	YC 6 R1/4	9.5	46.3	14.8	14
6	R3/8	10.5	26.8	19	CV 6 R3/8	53.4	UE 6 R3/8	31.9	YC 6 R3/8	10.5	47.8	14.8	17
6	R1/2	13.5	29.8	24	CV 6 R1/2	57.9			YC 6 R1/2	13.5	51.3	14.8	21
8	R1/8	7	25.6	10	CV 8 R1/8	39.7	UE 8 R1/8	23	YC 8 R1/8	7	46.6	18.2	14
8	R1/4	9.5	28.6	14	CV 8 R1/4	46.4	UE 8 R1/4	26.3	YC 8 R1/4	9.5	49.1	18.2	14
8	R3/8	10.5	29.6	19	CV 8 R3/8	53.4	UE 8 R3/8	31.9	YC 8 R3/8	10.5	50.6	18.2	17
8	R1/2	13.5	32.6	24	CV 8 R1/2	57.9	UE 8 R1/2	38.6	YC 8 R1/2	13.5	54.1	18.2	21
10	R1/8	7	28.8	10	CV 10 R1/8	39.7			YC 10 R1/8	7	54.6	19.5	17
10	R1/4	9.5	31	14	CV 10 R1/4	46.4	UE 10 R1/4	26.3	YC 10 R1/4	9.5	57.1	19.5	17
10	R3/8	10.5	31.6	19	CV 10 R3/8	53.4	UE 10 R3/8	31.9	YC 10 R3/8	10.5	58.1	19.5	17
10	R1/2	13.5	34.6	24	CV 10 R1/2	57.9	UE 10 R1/2	38.6	YC 10 R1/2	13.5	61.6	19.5	21
12	R1/4	9.5	33.5	14	CV 12 R1/4	46.4	UE 12 R1/4	26.3	YC 12 R1/4	9.5	62.1	21.6	21
12	R3/8	10.5	35.6	19	CV 12 R3/8	53.4	UE 12 R3/8	31.9	YC 12 R3/8	10.5	63.1	21.6	21
12	R1/2	13.5	36.6	24	CV 12 R1/2	57.9	UE 12 R1/2	38.6	YC 12 R1/2	13.5	66.1	21.6	21

Units in mm

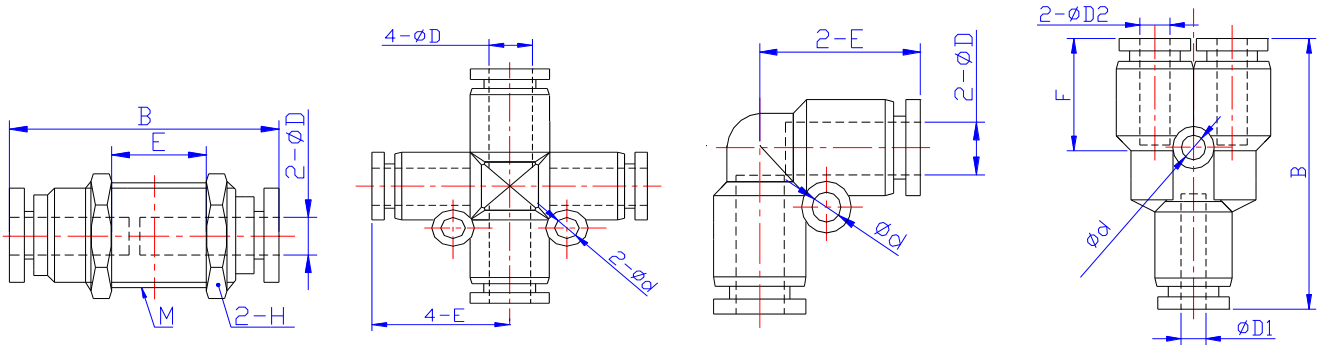

Bulkhead Union (BU)

Cross Union (CU)

Elbow Union (EU)

Reduced Branch (RB)

Model	Bulkhead Union					Cross Union			Elbow Union			Reduced Branch					
	Model	B	E	H	M	Model	∅d	E	Model	E	∅d	Model	∅D1	∅D2	∅d	B	F
5/32	BU 5/32	30.1	9.7	14.3	M12	CU 5/32	3.2	17.5	EU 5/32	17.5	3.2	RB 3/16-5/32	3/16	5/32	3.2	35.8	14.0
3/16	BU 3/16	31.8	7.5	17.4	M14	CU 3/16	3.2	17.8	EU 3/16	17.8	3.2	RB 1/4-5/32	1/4	5/32	3.2	36.8	14.5
1/4	BU 1/4	31.8	7.5	17.4	M14	CU 1/4	3.2	19.3	EU 1/4	19	3.2	RB 1/4-3/16	1/4	3/16	3.2	37.1	14.8
5/16	BU 5/16	35.3	6.8	19.0	M16	CU 5/16	3.2	22.75	EU 5/16	22.8	3.2	RB 5/16-1/4	5/16	1/4	3.2	39.9	17.7
3/8	BU 3/8	36.4	8.9	22.2	M20	CU 3/8	4.2	27	EU 3/8	26.3	4.2	RB 3/8-5/16	3/8	5/16	4.2	47.9	20.3
1/2	BU 1/2	45.3	12.8	25.4	M22	CU 1/2	4.3	29.6	EU 1/2	29.6	4.3	RB 1/2-3/8	1/2	3/8	4.2	51.6	20.0
4	BU 4	30.1	9.7	14.0	M12	CU 4	3.2	17.5	EU 4	17.5	3.2						
6	BU 6	31.8	7.5	17.0	M14	CU 6	3.2	19.3	EU 6	19	3.2	RB 6-4	6	4	3.2	36.8	14.5
8	BU 8	35.3	6.8	19.0	M16	CU 8	3.2	22.75	EU 8	22.8	3.2	RB 8-6	8	6	3.2	39.9	17.7
10	BU 10	39	11.5	24.0	M20	CU 10	4.2	27	EU 10	26.3	4.2	RB 10-8	10	8	4.2	47.9	20.3
12	BU 12	45.3	12.8	27.0	M22	CU 12	4.3	29.6	EU 12	29.6	4.3	RB 12-10	12	10	4.2	51.6	20

Units in mm

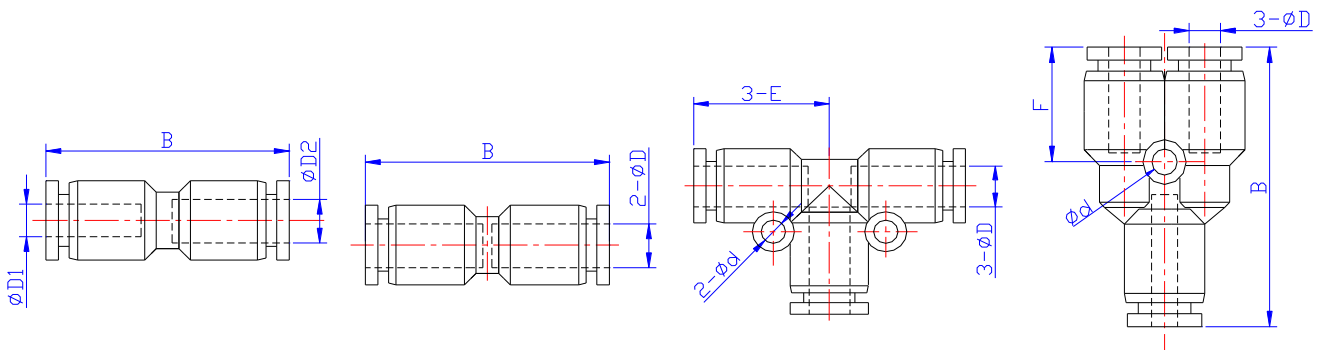

Reduced Union, RU

Straight Union, SU

Tee Union, TU

Y Union, YU

Reduced Union				Straight Union			Tee Union				Y Union				
Part No.	∅D1	∅D2	B	Part No.	∅D	B	Part No.	∅D	∅d	E	Part No.	∅D	∅d	B	F
				SU 5/32	5/32	33	TU 5/32	5/32	3.2	18.5	YU 5/32	5/32	3.2	35.5	14.0
RU 3/16-5/32	3/16	5/32	33.3	SU 3/16	3/16	33.6	TU 3/16	3/16	3.2	18.8	YU 3/16	3/16	3.2	36.1	14.3
RU 1/4-5/32	1/4	5/32	34.9	SU 1/4	1/4	35.2	TU 1/4	1/4	3.2	19.3	YU 1/4	1/4	3.2	37.1	14.8
RU 1/4-3/16	1/4	3/16	35.2												
RU 5/16-1/4	5/16	1/4	38.6	SU 5/16	5/16	39.1	TU 5/16	5/16	3.2	22.75	YU 5/16	5/16	3.2	40.4	18.2
RU 3/8-1/4	3/8	1/4		SU 3/8	3/8	45.2	TU 3/8	3/8	4.2	27	YU 3/8	3/8	4.2	47.1	19.5
RU 3/8-5/16	3/8	5/16	47.3												
RU 1/2-3/8	1/2	3/8	48.9	SU 1/2	1/2	49.2	TU 1/2	1/2	4.3	29.6	YU 1/2	1/2	4.2	53.2	21.6
RU 6-4	4	6	33.6	SU 4	4	33	TU 4	4	3.2	18.5	YU 4	4	3.2	35.5	14
RU 8-6	6	8	36.1	SU 6	6	35.2	TU 6	6	3.2	19.3	YU 6	6	3.2	37.1	14.8
RU 10-8	8	10	41.8	SU 8	8	39.1	TU 8	8	3.2	22.75	YU 8	8	3.2	40.4	18.2
RU 12-10	10	12	46.1	SU 10	10	45.2	TU 10	10	4.2	27	YU 10	10	4.2	47.1	19.5
				SU 12	12	49.2	TU 12	12	4.3	29.6	YU 12	12	4.2	53.2	21.6

Units in mm

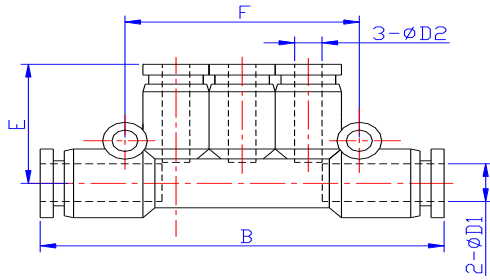

Manifold Union (MU)

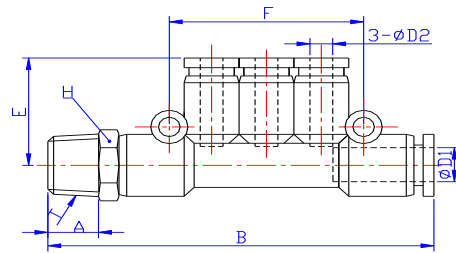

Male Manifold (MM)

Manifold Union					Manifold Union					Male Manifold									
MU					MU					MM									
Part No.	ØD	F	E	B	Part No.	ØD1	ØD2	B	E	F	Part No.	ØD1	ØD2	T	A	B	E	F	H
MU 5/32	5/32	36	19	57	MU 3/16X5/32	3/16	5/32	57.6	19	36	MM 3/16-5/32-N1/8	3/16	5/32	NPT 1/8	7.5	64.3	19	36	11.1
MU 3/16	3/16	36	19.3	57.6	MU 1/4X5/32	1/4	5/32	57.6	19	36	MM 1/4-5/32-N1/8	1/4	5/32	NPT 1/8	7.5	64.3	19	36	12.7
MU 1/4	1/4	42	20.3	61.6	MU 5/16X5/32	5/16	5/32	62.6	20	42	MM 5/16-5/32-N1/4	5/16	5/32	NPT 1/4	10.5	72.3	20	42	14.3
MU 5/16	5/16	48	24.3	81.6	MU 5/16X3/16	5/16	3/16	62.6	20.3	42	MM 5/16-3/16-N1/4	5/16	3/16	NPT 1/4	10.5	72.3	20.3	42	14.3
					MU 5/16X1/4	5/16	1/4	62.6	20.3	42	MM 5/16-1/4-N1/4	5/16	1/4	NPT 1/4	10.5	72.3	20.3	42	14.3
MU 4	4	36	19	57	MU 3/8X1/4	3/8	1/4	80	23.8	48	MM 3/8-5/16-N3/8	3/8	5/16	NPT 3/8	11	91.5	24.3	48	17.4
MU 6	6	42	20.3	61.6	MU 3/8X5/16	3/8	5/16	80	24.3	48									
MU 8	8	48	24.3	81.6															
					MU 6-4	6.0	4.0	57.6	19.0	36	MM 6-4-R1/8	6.0	4.0	R1/8	7	63.8	19	36	12
					MU 8-4	8.0	4.0	62.6	20.0	42	MM 8-4-R1/4	8.0	4.0	R1/4	9.5	71.3	20	42	14
					MU 8-6	8.0	6.0	62.6	20.3	42	MM 8-6-R1/4	8.0	6.0	R1/4	9.5	71.3	20.3	42	14
					MU 10-6	10.0	6.0	80.0	23.8	48									
					MU 10-8	10.0	8.0	80.0	24.3	48	MM10-8-R3/8	10.0	8.0	R3/8	10.5	91	24.3	48	17

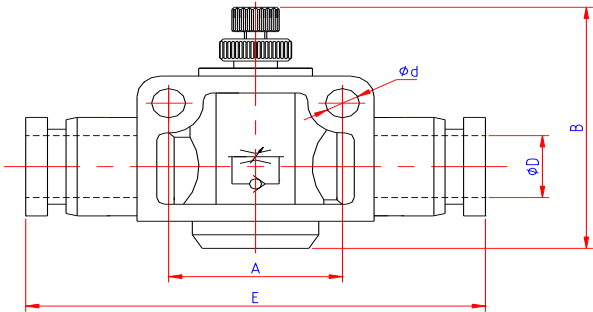

Air Flow Control Valve (FV)

Air Flow Control Valve					
FV					
Part No.	ØD	Ød	A	B	E
FV 5/32	5/32	3.2	14	28.8	39.5
FV 3/16	3/16	3.2	14	28.8	40.1
FV 1/4	1/4	4.3	20	42.6	47.6
FV 5/16	5/16	4.3	22	44.3	52.6
FV 3/8	3/8	4.3	26	53.4	60.5
FV 1/2	1/2	4.3	32	55.6	74.2

FV 4	4	3.2	14	28.8	39.5
FV 6	6	4.3	20	42.6	47.6
FV 8	8	4.3	22	44.3	52.6
FV 10	10	4.3	26	53.4	60.5
FV 12	12	4.3	32	55.6	74.2

Units in mm

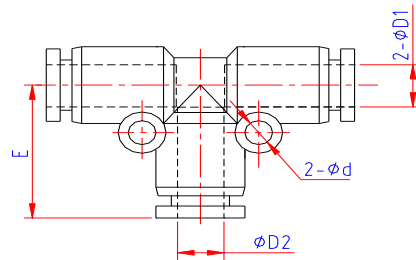

Tee Union Reducer (TU)

Tee Union Reducer				
TU				
Part No.	ØD1	ØD2	Ød	E
TU 1/4-5/32	1/4	5/32	3.2	19.0
TU 5/16-1/4	5/16	1/4	3.2	22.3
TU 3/8-5/16	3/8	5/16	3.2	27.8
TU 1/2-3/8	1/2	3/8	4.2	29.3

TU 6-4	6	4	3.2	19.5
TU 8-6	8	6	3.2	20.3
TU 10-8	10	8	4.2	24.8
TU 12-10	12	10	4.2	28.5

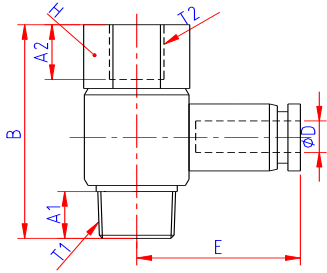

Stack Elbow (SE)

Stack Elbow								
SE								
ØD	T1	T2	Part No.	A1	A2	H	B	E
5/32	10-32UNF	10-32UNF	SE 5/32 10-32	3.8	5.5	11.1	19.5	20
	NPT1/8	NPT1/8	SE 5/32 N1/8	7.5	7.5	14.3	30	22.3
3/16	10-32UNF	10-32UNF	SE 3/16 10-32	3.8	5.5	11.1	19.5	20.3
	NPT1/8	NPT1/8	SE 3/16 N1/8	7.5	7.5	14.3	30	22.6
	NPT1/4	NPT1/4	SE 3/16 N1/4	10.5	10.5	17.4	35.8	24.3
1/4	NPT1/8	NPT1/8	SE 1/4 N1/8	7.5	7.5	14.3	30	23.1
	NPT1/4	NPT1/4	SE 1/4 N1/4	10.5	10.5	17.4	35.8	25.1
5/16	NPT1/8	NPT1/8	SE 5/16 N1/8	7.5	7.5	14.3	30	25.6
	NPT1/4	NPT1/4	SE 5/16 N1/4	10.5	10.5	17.4	35.8	28.6
	NPT3/8	NPT3/8	SE 5/16 N3/8	11	11	22.2	40.9	29.6
3/8	NPT1/4	NPT1/4	SE 3/8 N1/4	10.5	10.5	17.4	35.8	31
	NPT3/8	NPT3/8	SE 3/8 N3/8	11	11	22.2	40.9	31.6
1/2	NPT3/8	NPT3/8	SE 1/2 N3/8	11	11	22.2	40.9	35.6
	NPT1/2	NPT1/2	SE 1/2 N1/2	14	14	25.4	49	36.6

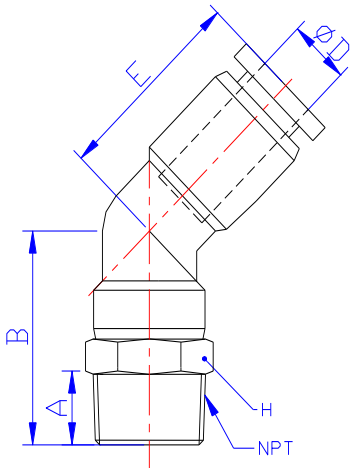

Male Angle (MA)

Male Angle						
MA						
ØD	NPT	Part No.	A	B	E	H
5/32	10-32UNF	MA 5/32 10-32	3.8	20.7	16.2	11.1
	NPT1/8	MA 5/32 N1/8	7.5	22.7	16.2	11.1
	NPT1/4	MA 5/32 N1/4	10.5	26.7	16.2	14.3
3/16	10-32UNF	MA 3/16 10-32	3.8	20.7	16.5	11.1
	NPT1/8	MA 3/16 N1/8	7.5	23.2	16.5	11.1
	NPT1/4	MA 3/16 N1/4	10.5	26.7	16.5	14.3
1/4	NPT3/8	MA 3/16 N3/8	11	27.7	16.5	17.4
	10-32UNF	MA 1/4 10-32	3.8	23.1	17.7	12.7
	NPT1/8	MA 1/4 N1/8	7.5	24.4	17.7	12.7
5/16	NPT1/4	MA 1/4 N1/4	10.5	27.9	17.7	14.3
	NPT3/8	MA 1/4 N3/8	11	28.9	17.7	17.4
	NPT1/8	MA 5/16 N1/8	7.5	27.6	20.9	14.3
3/8	NPT1/4	MA 5/16 N1/4	10.5	30.6	20.9	14.3
	NPT3/8	MA 5/16 N3/8	11	31.6	20.9	17.4
	NPT1/8	MA 3/8 N1/8	7.5	30.2	22.2	17.4
1/2	NPT1/4	MA 3/8 N1/4	10.5	33.2	22.2	17.4
	NPT3/8	MA 3/8 N3/8	11	33.7	22.2	17.4
	NPT1/2	MA 3/8 N1/2	14	37.2	22.2	22.2
1/2	NPT1/4	MA 1/2 N1/4	10.5	36.2	26.3	22.2
	NPT3/8	MA 1/2 N3/8	11	36.7	26.3	22.2
	NPT1/2	MA 1/2 N1/2	14	39.7	26.3	22.2

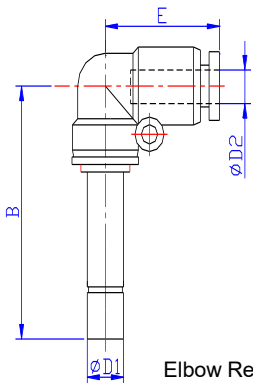

Elbow Reducer (ER)

Elbow Reducer				
ER				
Part No.	ØD1	ØD2	B	E
ER 5/32-3/16	5/32	3/16	33	17.5
ER 1/4-5/32	1/4	5/32	35	17.5
ER 3/16-1/4	3/16	1/4	35	17.5
ER 5/16-1/4	5/16	1/4	39.2	19
ER 3/8-5/16	3/8	5/16	42.5	22.8
ER 1/2-3/8	1/2	3/8	52.8	26.3
ER 6-4	6	4	35	17.5
ER 8-6	8	6	39.2	19
ER 10-8	10	8	44	22.8
ER 12-10	12	10	48.5	26.3

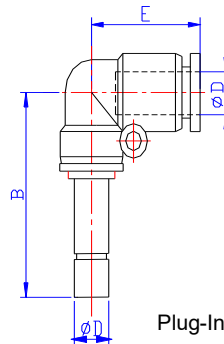

Plug-In Elbow (PE)

Plug-In Elbow			
PE			
Part No.	ØD	B	E
PE 5/32	5/32	33	17.5
PE 3/16	3/16	33	17.8
PE 1/4	1/4	36.2	19
PE 5/16	5/16	42.5	22.8
PE 3/8	3/8	50.8	26.3
PE 1/2	1/2	54.5	29.6

Units in mm

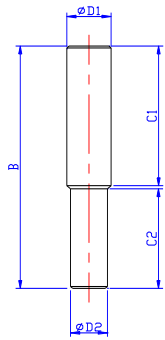

Stem Reducer (SR)

Stem Reducer					
SR					
Part No.	ØD1	ØD2	C1	C2	B
SR 3/16-5/32	3/16	5/32	18	17	36
SR 1/4-5/32	1/4	5/32	18	17	36
SR 1/4-3/16	1/4	3/16	18	17	36
SR 5/16-1/4	3/16	1/4	20	18	39
SR 3/8-5/16	3/8	5/16	25	20	46
SR 1/2-3/8	1/2	3/8	27	26	54

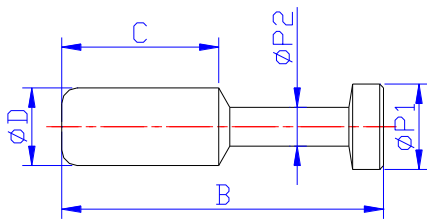

Plug (PG)

Plug					
PG					
Part No.	ØD	B	ØP1	ØP2	C
PG 5/32	5/32	28	5	3	15
PG 3/16	3/16	28	5	3	15
PG 1/4	1/4	33	7	3	17
PG 5/16	5/16	37	9	4	18
PG 3/8	3/8	42	11	5	20.5
PG 1/2	1/2	44	13	6	23

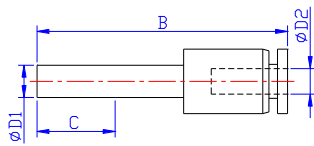

Tube Reducer (TR)

Tube Reducer				
TR				
Part No.	ØD1	ØD2	B	C
TR 5/32-1/4	1/4	5/32	39.5	16
TR 5/32-5/16	5/16	5/32	41.5	18.6
TR 1/4-5/16	5/16	1/4	41.8	18.6
TR 1/4-3/8	3/8	1/4	46.5	20
TR 5/16-3/8	3/8	5/16	46.5	20
TR 1/4-1/2	1/2	1/4	51.8	23.5
TR 5/16-1/2	1/2	5/16	52.3	23.5
TR 3/8-1/2	1/2	3/8	51.5	23.5

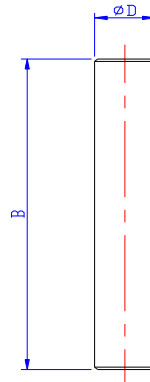

Stem Coupling (SC)

Stem Coupling		
SC		
Part No.	ØD	B
SC 5/32	5/32	35
SC 3/16	3/16	35
SC 1/4	1/4	37
SC 5/16	5/16	41
SC 3/8	3/8	51
SC 1/2	1/2	54

Units in mm

Composite Angle Flow Control Air Valves Flow Rate

STC FLOW CONTROL VALVES AIR FLOW CHARACTERISTICS

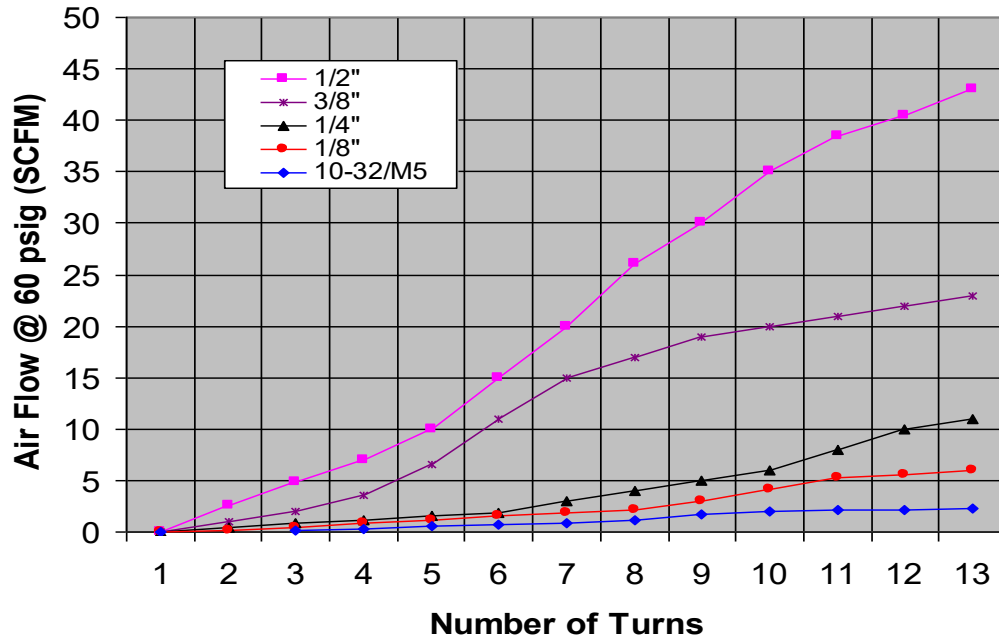

Special Features:

- Complete rotation of the valve body around the bolt allows for optimum positioning of tubing
- Compact size provides space saving installations
- Special adjustment needle design allows large adjustment with high precision
- Adjustment needles and banjo bodies are retained, preventing accidental loss of needle or lock nut.

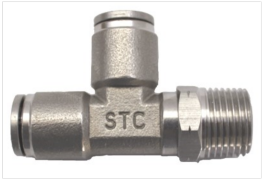

Fine Quality

Precision Engineered



Advanced Design



Excellent Prices

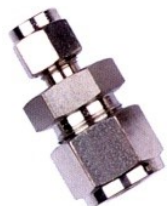

Contents

Fittings Numbering System.....	B2
Stainless Steel Push-In Fittings List Price.....	B3 - B4
Stainless Steel Push-In Fittings Specifications.....	B5
Stainless Steel Fittings Dimensions.....	B6 - B8
Compression & Barb Fittings Numbering System.....	B9
Compression Fittings Specifications.....	B9
Compression Fittings List Price.....	B10 - B11
Barb Compression Fittings List Price.....	B12
Barb Compression Fittings Specifications.....	B12

Ordering Part No. =
(e.g., BCS 1/4 N3/8 W)

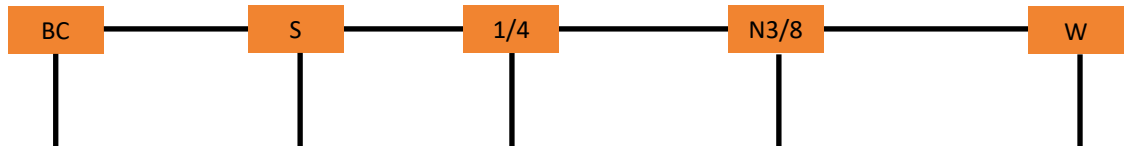

Fitting Name	
Branch Tee	BT
Bulkhead Connector	BC
Bulkhead Union	BU
Cartridge Fitting	CF
Elbow Union	EU
Female Connector	FC
Female Elbow	FE
Hex Bushing	HB
Male Connector	MC
Male Elbow	ME
Plug In Elbow	PE
Reducing Union	RU
Run Tee	RT
Straight Union	SU
Tee Union	TU
Tube Adaptor	TA
Tube Connector	TC
Tube Reducer	TR

Material / Type	
316 Stainless Steel	S

Tube OD	
Inches	1/8
	5/32
	3/16
	1/4
	5/16
	3/8
mm	1/2
	4
	6
	8
	10
	12
14	
16	

Thread Size / Stem / Tube	
N = NPT	N1/8
	N1/4
	N3/8
	N1/2
R = PT (British Standard Pipe Taper Thread)	R1/8
	R1/4
	R3/8
	R1/2
G = PP (British Standard Parallel Pipe Thread)	G1/8
	G1/4
	G3/8
	G1/2
U = Universal Threads (fits NPT, R, & G)	U1/8
	U1/4
	U3/8
Machine Thread	U1/2
	10-32
	M5
M6	
Stem Size	1/8-1/2"
	4-12mm

Stainless Steel Fitting Options—Tube Gripping/ Releasing Mechanism	
Collet style with Stainless Steel Release Button	(leave blank)
Gripper Style with Stainless Steel Release Button	W

Stainless Steel Fittings													
Model		Bulkhead Connector		Branch Tee (Swivel)		Female Connector		Male Connector		Male Elbow (Swivel)		Run Tee (Swivel)	
		BCS		BTS		FCS		MCS		MES		RTS	
Tube OD	Thread	Part No.	Unit Price	Part No.	Unit Price	Part No.	Unit Price	Part No.	Unit Price	Part No.	Unit Price	Part No.	Unit Price
1/8"	10-32	BCS 1/8 10-32 W	\$28.77	BTS 1/8 10-32 W	\$29.81	FCS 1/8 10-32 W	\$12.38	MCS 1/8 10-32 W	\$10.61	MES 1/8 10-32 W	\$21.11	RTS 1/8 10-32 W	\$29.81
1/8"	NPT1/8	BCS 1/8 N1/8 W	\$28.77	BTS 1/8 N1/8 W	\$29.81	FCS 1/8 N1/8 W	\$12.38	MCS 1/8 N1/8 W	\$10.61	MES 1/8 N1/8 W	\$21.11	RTS 1/8 N1/8 W	\$29.81
1/8"	NPT1/4	BCS 1/8 N1/4 W	\$31.84	BTS 1/8 N1/4 W	\$31.33	FCS 1/8 N1/4 W	\$17.38	MCS 1/8 N1/4 W	\$11.14	MES 1/8 N1/4 W	\$25.36	RTS 1/8 N1/4 W	\$31.33
5/32"	10-32	BCS 5/32 10-32 W	\$28.77	BTS 5/32 10-32 W	\$29.81	FCS 5/32 10-32 W	\$12.38	MCS 5/32 10-32 W	\$10.61	MES 5/32 10-32 W	\$21.10	RTS 5/32 10-32 W	\$29.81
5/32"	NPT1/8	BCS 5/32 N1/8 W	\$28.77	BTS 5/32 N1/8 W	\$29.81	FCS 5/32 N1/8 W	\$12.38	MCS 5/32 N1/8 W	\$10.61	MES 5/32 N1/8 W	\$21.10	RTS 5/32 N1/8 W	\$29.81
5/32"	NPT1/4	BCS 5/32 N1/4 W	\$31.84	BTS 5/32 N1/4 W	\$32.87	FCS 5/32 N1/4 W	\$16.53	MCS 5/32 N1/4 W	\$10.61	MES 5/32 N1/4 W	\$21.10	RTS 5/32 N1/4 W	\$32.87
1/4"	10-32	BCS 1/4 10-32 W	\$32.65	BTS 1/4 10-32 W	\$29.81	FCS 1/4 10-32 W	\$12.38	MCS 1/4 10-32 W	\$10.61	MES 1/4 10-32 W	\$22.46	RTS 1/4 10-32 W	\$29.81
1/4"	NPT1/8	BCS 1/4 N1/8 W	\$32.65	BTS 1/4 N1/8 W	\$29.81	FCS 1/4 N1/8 W	\$12.38	MCS 1/4 N1/8 W	\$10.61	MES 1/4 N1/8 W	\$22.46	RTS 1/4 N1/8 W	\$29.81
1/4"	NPT1/4	BCS 1/4 N1/4 W	\$32.65	BTS 1/4 N1/4 W	\$34.28	FCS 1/4 N1/4 W	\$12.38	MCS 1/4 N1/4 W	\$10.61	MES 1/4 N1/4 W	\$24.29	RTS 1/4 N1/4	\$34.28
1/4"	NPT3/8	BCS 1/4 N3/8 W	\$34.17	BTS 1/4 N3/8 W	\$39.10	FCS 1/4 N3/8 W	\$13.33	MCS 1/4 N3/8 W	\$11.57	MES 1/4 N3/8 W	\$25.27	RTS 1/4 N3/8	\$39.10
5/16"	NPT1/8	BCS 5/16 N1/8 W	\$34.17	BTS 5/16 N1/8 W	\$37.48	FCS 5/16 N1/8 W	\$17.47	MCS 5/16 N1/8 W	\$14.11	MES 5/16 N1/8 W	\$25.70	RTS 5/16 N1/8 W	\$37.48
5/16"	NPT1/4	BCS 5/16 N1/4 W	\$34.17	BTS 5/16 N1/4 W	\$37.48	FCS 5/16 N1/4 W	\$17.47	MCS 5/16 N1/4 W	\$14.11	MES 5/16 N1/4 W	\$26.54	RTS 5/16 N1/4 W	\$37.48
5/16"	NPT3/8	BCS 5/16 N3/8 W	\$34.17	BTS 5/16 N3/8 W	\$43.08	FCS 5/16 N3/8 W	\$17.47	MCS 5/16 N3/8 W	\$14.92	MES 5/16 N3/8 W	\$27.14	RTS 5/16 N3/8 W	\$43.08
5/16"	NPT 1/2	BCS 5/16 N1/2 W	\$35.71	BTS 5/16 N1/2 W	\$44.62	FCS 5/16 N1/2 W	\$20.53	MCS 5/16 N1/2 W	\$16.14	MES 5/16 N1/2 W	\$32.73	RTS 5/16 N1/2 W	\$45.61
3/8"	NPT 1/8	BCS 3/8 N1/8 W	\$38.05	BTS 3/8 N1/8 W	\$43.08	FCS 3/8 N1/8 W	\$21.21	MCS 3/8 N1/8 W	\$14.11	MES 3/8 N1/8 W	\$28.11	RTS 3/8 N1/8 W	\$43.08
3/8"	NPT1/4	BCS 3/8 N1/4 W	\$38.05	BTS 3/8 N1/4 W	\$43.08	FCS 3/8 N1/4 W	\$21.21	MCS 3/8 N1/4 W	\$14.11	MES 3/8 N1/4 W	\$28.11	RTS 3/8 N1/4 W	\$43.08
3/8"	NPT3/8	BCS 3/8 N3/8 W	\$38.05	BTS 3/8 N3/8 W	\$43.08	FCS 3/8 N3/8 W	\$22.99	MCS 3/8 N3/8 W	\$14.33	MES 3/8 N3/8 W	\$29.17	RTS 3/8 N3/8 W	\$43.08
3/8"	NPT1/2	BCS 3/8 N1/2 W	\$38.05	BTS 3/8 N1/2 W	\$47.88	FCS 3/8 N1/2 W	\$23.80	MCS 3/8 N1/2 W	\$16.14	MES 3/8 N1/2 W	\$33.42	RTS 3/8 N1/2 W	\$47.88
1/2"	NPT1/4	BCS 1/2 N1/4 W	\$41.03	BTS 1/2 N1/4 W	\$47.18	FCS 1/2 N1/4 W	\$21.35	MCS 1/2 N1/4 W	\$17.30	MES 1/2 N1/4 W	\$35.86	RTS 1/2 N1/4 W	\$47.18
1/2"	NPT3/8	BCS 1/2 N3/8 W	\$42.54	BTS 1/2 N3/8 W	\$47.18	FCS 1/2 N3/8 W	\$23.80	MCS 1/2 N3/8 W	\$17.30	MES 1/2 N3/8 W	\$35.86	RTS 1/2 N3/8 W	\$47.18
1/2"	NPT1/2	BCS 1/2 N1/2 W	\$45.61	BTS 1/2 N1/2 W	\$50.41	FCS 1/2 N1/2 W	\$24.57	MCS 1/2 N1/2 W	\$22.81	MES 1/2 N1/2 W	\$40.83	RTS 1/2 N1/2 W	\$50.41

4 mm	M5	BCS 4 M5 W	\$28.77	BTS 4 M5 W	\$29.81	FCS 4 M5 W	\$12.38	MCS 4 M5 W	\$10.61	MES 4 M5 W	\$21.10	RTS 4 M5 W	\$29.81
4 mm	R1/8	BCS 4 R1/8 W	\$28.77	BTS 4 R1/8 W	\$29.81	FCS 4 R1/8 W	\$12.38	MCS 4 R1/8 W	\$10.61	MES 4 R1/8 W	\$21.10	RTS 4 R1/8 W	\$29.81
4 mm	R1/4	BCS 4 R1/4 W	\$28.77	BTS 4 R1/4 W	\$29.81	FCS 4 R1/4 W	\$12.38	MCS 4 R1/4 W	\$12.23	MES 4 R1/4 W	\$21.10	RTS 4 R1/4 W	\$29.81
6mm	M5	BCS 6 M5 W	\$32.65	BTS 6 M5 W	\$29.81	FCS 6 M5 W	\$12.38	MCS 6 M5 W	\$12.23	MES 6 M5 W	\$24.29	RTS 6 M5 W	\$29.81
6mm	R1/8	BCS 6 R1/8 W	\$32.65	BTS 6 R1/8 W	\$29.81	FCS 6 R1/8 W	\$12.38	MCS 6 R1/8 W	\$12.23	MES 6 R1/8 W	\$22.48	RTS 6 R1/8 W	\$29.81
6mm	R1/4	BCS 6 R1/4 W	\$32.65	BTS 6 R1/4 W	\$34.28	FCS 6 R1/4 W	\$12.38	MCS 6 R1/4 W	\$12.23	MES 6 R1/4 W	\$24.29	RTS 6 R1/4 W	\$34.28
6mm	R3/8	BCS 6 R3/8 W	\$34.17			FCS 6 R3/8 W	\$15.89	MCS 6 R 3/8 W	\$14.92	MES 6 R3/8 W	\$30.22		
8mm	R1/8	BCS 8 R1/8 W	\$34.17			FCS 8 R1/8 W	\$15.89	MCS 8 R1/8 W	\$14.11	MES 8 R1/8 W	\$26.96	RTS 8 R1/8 W	\$37.48
8 mm	R1/4	BCS 8 R1/4 W	\$34.17	BTS 8 R1/4 W	\$37.48	FCS 8 R1/4 W	\$15.89	MCS 8 R1/4 W	\$14.11	MES 8 R1/4 W	\$26.96	RTS 8 R1/4 W	\$37.48
8 mm	R3/8	BCS 8 R3/8 W	\$34.17	BTS 8 R3/8 W	\$40.72	FCS 8 R3/8 W	\$17.47	MCS 8 R3/8 W	\$14.92	MES 8 R3/8 W	\$27.14	RTS 8 R3/8 W	\$40.72
10mm	R1/4	BCS 10 R1/4 W	\$38.05	BTS 10 R1/4 W	\$43.08	FCS 10 R1/4 W	\$19.08	MCS 10 R1/4 W	\$14.11	MES 10 R1/4 W	\$28.11	RTS 10 R1/4 W	\$43.08
10mm	R3/8	BCS 10 R3/8 W	\$38.05	BTS 10 R3/8 W	\$43.08	FCS 10 R3/8 W	\$20.37	MCS 10 R3/8 W	\$14.33	MES 10 R3/8 W	\$29.17	RTS 10 R3/8 W	\$43.08
12mm	R1/4	BCS 12 R1/4 W	\$42.54			FCS 12 R1/4 W	\$21.35	MCS 12 R1/4 W	\$17.30	MES 12 R1/4 W	\$40.83		
12mm	R3/8	BCS 12 R3/8 W	\$42.54	BTS 12 R3/8 W	\$47.18	FCS 12 R3/8 W	\$21.35	MCS 12 R3/8 W	\$17.30	MES 12 R3/8 W	\$35.86	RTS 12 R3/8 W	\$47.18
12mm	R1/2	BCS 12 R1/2 W	\$42.54	BTS 12 R1/2 W	\$50.41	FCS 12 R1/2 W	\$24.57	MCS 12 R1/2 W	\$22.81	MES 12 R1/2 W	\$40.83	RTS 12 R1/2 W	\$50.41

Stainless Steel Push-In Fittings List Price

Stainless Steel Fittings								
	Bulkhead Union		Elbow Union		Hex Plug		Plug	
	BUS		EUS		PGS		PGS	
Model	Part No.	Unit Price	Part No.	Unit Price	Part No.	Price	Part No.	Price
Tube OD								
1/8"	BUS 1/8 W	\$20.27	EUS 1/8 W	\$24.30	PGS N1/8	\$7.03	PGS 1/8	\$3.49
5/32"	BUS 5/32 W	\$20.27	EUS 5/32 W	\$24.29			PGS 5/32	\$2.78
1/4"	BUS 1/4 W	\$23.87	EUS 1/4 W	\$27.91	PGS N1/4	\$6.78	PGS 1/4	\$3.49
5/16"	BUS 5/16 W	\$30.54	EUS 5/16 W	\$29.17			PGS 5/16	\$1.96
3/8"	BUS 3/8 W	\$32.46	EUS 3/8 W	\$31.81	PGS N3/8	\$8.93	PGS 3/8	\$2.01
1/2"	BUS 1/2 W	\$41.88	EUS 1/2 W	\$36.60	PGS N1/2	\$21.45	PGS 1/2	\$2.45

4 mm	BUS 4 W	\$20.27	EUS 4 W	\$24.29				
6 mm	BUS 6 W	\$28.64	EUS 6 W	\$27.91			PGS 6	\$2.45
8 mm	BUS 8 W	\$30.54	EUS 8 W	\$29.17				
10 mm	BUS 10 W	\$32.46	EUS 10 W	\$31.81			PGS 10	\$2.45
12 mm	BUS 12 W	\$41.88	EUS 12 W	\$36.60			PGS 12	\$2.45

Stainless Steel Fittings								
	Straight Union		Tube Connector		Tee Union		Cartridge Fitting	
	SUS		TCS		TUS		CFS	
Model	Part No.	Unit Price	Part No.	Unit Price	Part No.	Unit Price	Part No.	Unit Price
Tube OD								
1/8"	SUS 1/8 W	\$15.28	TCS 1/8	\$3.65	TUS 1/8 W	\$29.81	CFS 1/8 W	\$13.48
5/32"	SUS 5/32 W	\$15.28	TCS 5/32	\$3.65	TUS 5/32 W	\$29.81	CFS 5/32 W	\$12.10
1/4"	SUS 1/4 W	\$15.28	TCS 1/4	\$3.65	TUS 1/4 W	\$34.28	CFS 1/4 W	\$10.41
5/16"	SUS 5/16 W	\$16.65	TCS 5/16	\$3.65	TUS 5/16 W	\$38.69	CFS 5/16 W	\$11.33
3/8"	SUS 3/8 W	\$18.04	TCS 3/8	\$4.39	TUS 3/8 W	\$43.08	CFS 3/8 W	\$11.94
1/2"	SUS 1/2 W	\$21.84	TCS 1/2	\$5.10	TUS 1/2 W	\$50.41	CFS 1/2 W	\$12.71

4 mm	SUS 4 W	\$15.28			TUS 4 W	\$29.81	CFS 4 W	\$12.10
6 mm	SUS 6 W	\$15.28			TUS 6 W	\$34.28	CFS 6 W	\$10.41
8 mm	SUS 8 W	\$16.65			TUS 8 W	\$38.69	CFS 8 W	\$11.33
10 mm	SUS 10 W	\$18.04	TCS 10	\$4.39	TUS 10 W	\$43.08	CFS 10 W	\$11.94
12 mm	SUS 12 W	\$21.84			TUS 12 W	\$50.41	CFS 12 W	\$12.71

Stainless Steel Fittings											
	Reduced Union		Tube Reducer			Tube Adaptor		Hex Bushing			
	RUS		TRS			TAS		HBS			
Model	Part No.	Unit Price	Part No.	Unit Price	Model	Part No.	Unit Price	Part No.	Unit Price		
ØD1	ØD2				Tube OD	Thread					
1/8"	5/32"	RUS 5/32-1/8 W	\$20.27		1/8"	10-32	TAS 1/8 10-32	\$6.73			
5/32"	1/8"			TRS 1/8-5/32 W	\$15.28	1/8"	NPT1/8	TAS 1/8 N1/8	\$6.73	HBS MN1/4-FN1/8	\$3.70
5/32"	1/4"	RUS 1/4-5/32 W	\$23.87			1/4"	NPT1/8	TAS 1/4 N1/8	\$6.73		
1/4"	5/32"			TRS 5/32-1/4 W	\$15.28	1/4"	NPT1/4	TAS 1/4 N1/4	\$6.73		
3/8"	1/4"	RUS 3/8-1/4 W	\$32.46			1/4"	NPT3/8	TAS 1/4 N3/8	\$6.73		
3/8"	5/16"	RUS 3/8-5/16 W	\$32.46	TRS 1/4-3/8 W	\$15.28	5/16"	NPT1/4	TAS 5/16 N1/4	\$9.92		
3/8"	1/2"	RUS 1/2-3/8 W	\$41.88	TRS 5/16-3/8 W	\$16.65	5/16"	NPT3/8	TAS 5/16 N3/8	\$9.92		
1/2"	3/8"			TRS 3/8-1/2 W	\$18.04	3/8"	NPT1/8	TAS 3/8 N1/8	\$9.44	HBS MN3/8-FN1/8	\$4.63
						3/8"	NPT1/4	TAS 3/8 N1/4	\$9.92	HBS MN3/8-FFN1/4	\$5.55
6mm	4mm	RUS 6-4 W	\$28.64	TRS 4-6 W	\$13.69	3/8"	NPT3/8	TAS 3/8 N3/8	\$14.02		
8mm	6mm	RUS 8-6 W	\$30.51	TRS 6-8 W	\$15.28	3/8"	NPT1/2	TAS 3/8 N1/2	\$14.02		
10mm	6mm	RUS 10-6 W	\$29.50			1/2"	NPT1/4	TAS 1/2 N1/4	\$16.81	HBS MN1/2-FN1/4	\$5.55
10mm	8mm	RUS 10-8 W	\$32.46	TRS 8-10 W	\$16.65	1/2"	NPT3/8	TAS 1/2 N3/8	\$16.81	HBS MN1/2-FN3/8	\$5.55
12mm	10mm	RUS 12-10 W	\$41.88	TRS 10-12 W	\$18.04	1/2"	NPT1/2	TAS 1/2 N1/2	\$16.81		

6mm	N1/4	TAS 6 N1/4	\$6.73		
-----	------	------------	--------	--	--

A. Installation of Pipe Fittings:

Tighten fitting by hand, then turn it 2-3 turns with a wrench until it reaches the desired torque listed. If the fittings are not pre-coated with sealant, or is used and the sealant is not in good condition, apply Teflon sealant tape to the threads.

Recommendation of Torque for Tightening Fittings		
Fitting Thread Size	Torque, lb-ft	Torque, kgf/cm
10-32, M5 – M6	1.0 – 1.5	14 – 21
NPT1/8, R1/8	5 – 6.5	70 – 90
NPT1/4, R1/4	8.5 – 10	120 – 140
NPT3/8, R3/8	16 – 17.5	220 – 240
NPT1/2, R1/2	20 – 21.5	280 – 300

B. Installation of Tubing into Fitting:

1. Slowly push a clean and perpendicularly cut tube into the fitting until it comes to a dead stop.
2. Gently pull the tubing back until the Grip Ring or Collet of the fitting grips onto the tubing and has a good seal.
3. Use Polyethylene, Polypropylene, Polyurethane, or Nylon tubing designed for instant fittings.
4. Hard metal tubing can be used for all metal Stainless Steel if the tubing is pre-grooved.

C. Removal of Tubing from Fitting:

1. Push in evenly on the Release Button.
2. Pull out the tube while depressing the Release Button.
3. To reuse the tubing, cut off the lodged portion of the previously used tubing in an even and perpendicular fashion.

D. Recommended Tubing Material, Size, and Hardness Requirements:

Tubing Material	Specified Size	Hardness (Durometer)
Polyurethane	+/- 0.006" (+/-0.15 mm)	Shore A 85 or higher
Polyethylene	+/- 0.004" (+/-0.1 mm)	Shore D 44—D75
Polypropylene	+/- 0.004" (+/-0.1 mm)	Shore D 44—D75
Nylon	+/- 0.004" (+/-0.1 mm)	Shore D 44—D75
Pre-grooved Metal Tubing	+/- 0.004" (+/-0.1 mm)	

E. Specifications, Materials of Construction, and Schematics of Typical Construction:

Stainless Steel Fittings	
Operating Pressure Range	0 - 250 PSI (0 - 1650 kpa)
Vacuum	0 - 30" Hg (0 - 760 mm Hg)
Operating Temperature	5 - 230°F (-15 to 110°C)
Recommended Tubing Material	Polyurethane, Nylon, Polyethylene, Polypropylene, and Hard metal tubing (tubing must be pre-grooved)
Metal Body	T316 Stainless Steel
Plastic Body	None
Release Button	300 series Stainless Steel
Grip Ring or Collet	300 series Stainless Steel
O-ring	VITON
Thread Sealant	None
Service	Air, Liquid
Sterilization Temperature	Up to 280°F (138°C)

Stainless Steel (SS) Gripper-Style (W) Fitting
Materials of Construction

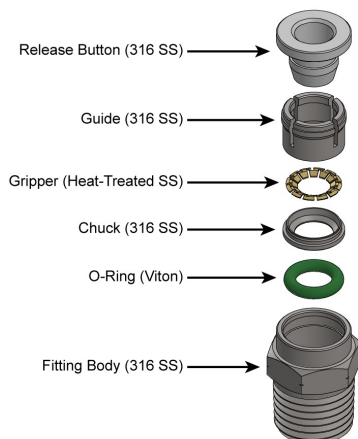

Stainless Steel (SS) Collet-Style Fitting
Materials of Construction

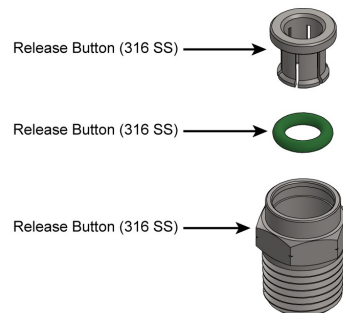

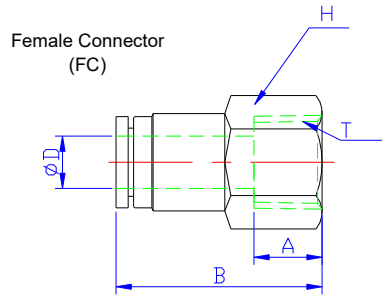

Model			Bulkhead Connector				Female Connector	
ΦD	T, Thread	B	BCS			FCS		
			Part No.	H1	H2	M	Part No.	H
1/8	10-32	24.2	BCS 1/8 10-32 W	S14	S14	M12X1	FCS 1/8 10-32 W	S11
1/8	1/8 NPT	27.2	BCS 1/8 N1/8 W	S14	S14	M12X1	FCS 1/8 N1/8 W	S14
1/8	1/4 NPT	30.2	BCS 1/8 N1/4 W	S17	S17	M14X1	FCS 1/8 N1/4 W	S17
5/32	10-32	24.2	BCS 5/32 10-32 W	S14	S14	M12X1	FCS 5/32 10-32 W	S11
5/32	1/8 NPT	27.2	BCS 5/32 N1/8 W	S14	S14	M12X1	FCS 5/32 N1/8 W	S14
5/32	1/4 NPT	30.2	BCS 5/32 N1/4 W	S17	S17	M12X1	FCS 5/32 N1/4 W	S17
3/16	1/8 NPT	29.2	BCS 3/16 N1/8 W	S17	S17	M14X1	FCS 3/16 N1/8 W	S14
3/16	1/4 NPT	32.2	BCS 3/16 N1/4 W	S17	S17	M14X1	FCS 3/16 N1/4 W	S17
1/4	10-32	26.2	BCS 1/4 10-32 W	S17	S17	M14X1	FCS 1/4 10-32 W	S14
1/4	1/8 NPT	29.2	BCS 1/4 N1/8 W	S17	S17	M14X1	FCS 1/4 N1/8 W	S14
1/4	1/4 NPT	32.2	BCS 1/4 N1/4 W	S17	S17	M14X1	FCS 1/4 N1/4 W	S17
1/4	3/8 NPT	33.2	BCS 1/4 N3/8 W	S19	S19	M14X1	FCS 1/4 N3/8 W	S19
5/16	1/8 NPT	31.1	BCS 5/16 N1/8 W	S19	S19	M17X1	FCS 5/16 N1/8 W	S17
5/16	1/4 NPT	34.1	BCS 5/16 N1/4 W	S19	S19	M17X1	FCS 5/16 N1/4 W	S17
5/16	3/8 NPT	37.1	BCS 5/16 N3/8 W	S19	S19	M17X1	FCS 5/16 N3/8 W	S19
3/8	1/8 NPT	34	BCS 3/8 N1/8 W	S21	S21	M19X1	FCS 3/8 N1/8 W	S19
3/8	1/4 NPT	37	BCS 3/8 N1/4 W	S21	S21	M19X1	FCS 3/8 N1/4 W	S19
3/8	3/8 NPT	38	BCS 3/8 N3/8 W	S21	S21	M19X1	FCS 3/8 N3/8 W	S19
3/8	1/2 NPT	40	BCS 3/8 N1/2 W	S24	S24	M22X1	FCS 3/8 N1/2 W	S24
1/2	1/4 NPT	39.5	BCS 1/2 N1/4 W	S24	S24	M22X1	FCS 1/2 N1/4 W	S22
1/2	3/8 NPT	40.5	BCS 1/2 N3/8 W	S24	S24	M22X1	FCS 1/2 N3/8 W	S22
1/2	1/2 NPT	42.5	BCS 1/2 N1/2 W	S24	S24	M22X1	FCS 1/2 N1/2 W	S24

4	M5	24.2	BCS 4 M5 W	S14	S14	M12X1	FCS 4 M5 W	S11
4	1/8 BSPT	27.2	BCS 4 R1/8 W	S14	S14	M12X1	FCS 4 R1/8 W	S14
4	1/4 BSPT	30.2	BCS 4 R1/4 W	S17	S17	M14X1	FCS 4 R1/4 W	S17
6	M5	26.2	BCS 6 M5 W	S17	S17	M14X1	FCS 6 M5 W	S14
6	1/8 BSPT	29.2	BCS 6 R1/8 W	S17	S17	M14X1	FCS 6 R1/8 W	S14
6	1/4 BSPT	32.2	BCS 6 R1/4 W	S17	S17	M14X1	FCS 6 R1/4 W	S17
6	3/8 BSPT	33.2	BCS 6 R3/8 W	S19	S19	M17X1	FCS 6 R3/8 W	S19
8	1/8 BSPT	31.1	BCS 8 R1/8 W	S19	S19	M17X1	FCS 8 R1/8 W	S17
8	1/4 BSPT	34.1	BCS 8 R1/4 W	S19	S19	M17X1	FCS 8 R1/4 W	S17
8	3/8 BSPT	37.1	BCS 8 R3/8 W	S19	S19	M17X1	FCS 8 R3/8 W	S19
8	1/2 BSPT	39.1	BCS 8 R1/2 W	S24	S24	M22X1	FCS 8 R1/2 W	S24
10	1/8 BSPT	34	BCS 10 R1/8 W	S21	S21	M19X1	FCS 10 R1/8 W	S19
10	1/4 BSPT	37	BCS 10 R1/4 W	S21	S21	M19X1	FCS 10 R1/4 W	S19
10	3/8 BSPT	38	BCS 10 R3/8 W	S21	S21	M19X1	FCS 10 R3/8 W	S21
10	1/2 BSPT	40	BCS 10 R1/2 W	S24	S24	M22X1	FCS 10 R1/2 W	S24
12	1/4 BSPST	39.5	BCS 12 R1/4 W	S24	S24	M22X1	FCS 12 R1/4 W	S22
12	3/8 BSPT	40.5	BCS 12 R3/8 W	S24	S24	M22X1	FCS 12 R3/8 W	S22
12	1/2 BSPT	42.5	BCS 12 R1/2 W	S24	S24	M22X1	FCS 12 R1/2 W	S24

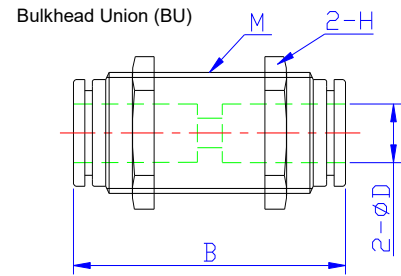

Bulkhead Union				
BUS				
ΦD	Part No.	B	H	M
1/8"	BUS 1/8 W	34.5	S14	M12X1
5/32"	BUS 5/32 W	35.1	S14	M12X1
3/16"	BUS 3/16 W	38.05	S17	M14X1
1/4"	BUS 1/4 W	38.05	S17	M14X1
5/16"	BUS 5/16 W	42.7	S19	M17X1
3/8"	BUS 3/8 W	48.4	S21	M19X1
1/2"	BUS 1/2 W	52.5	S24	M22X1

4	BUS 4 W	35.1	S14	M12X1
6	BUS 6 W	38.05	S17	M14X1
8	BUS 8 W	42.7	S19	M17X1
10	BUS 10 W	48.4	S21	M19X1
12	BUS 12 W	52.5	S24	M22X1

Model		Tube Reducer		
ΦD1	ΦD2	TR		
		Part No.	B	C
1/4	5/32	TRS 5/32-1/4W	33.4	9
5/16	5/32	TRS 5/32-5/16W	36.4	10.5
5/16	1/4	TRS 1/4-5/16W	40.3	10.5
3/8	1/4	TRS 1/4-3/8W	36.9	10.5
3/8	5/16	TRS 5/16-3/8W	43.1	10.5
1/2	1/4	TRS 1/4-1/2W	36.9	10.5
1/2	5/16	TRS 5/16-1/2W	39.1	10.5
1/2	3/8	TRS 3/8-1/2W	41.5	10.5

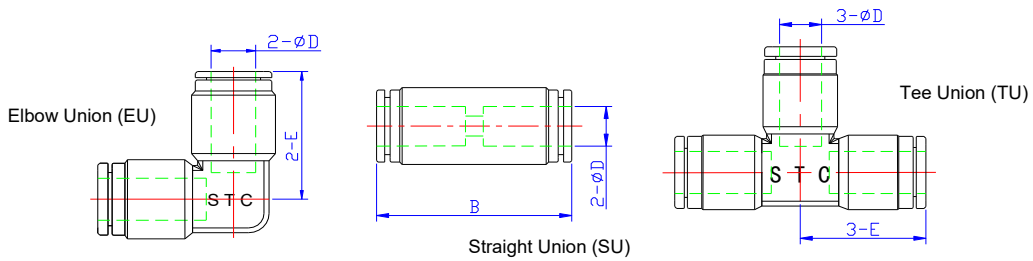

Model	Elbow Union		Reducing Union		Straight Union		Tee Union		Plug				
	EUS		RUS		SUS		TUS		PG S				
ΦD	Part No.	E	Part No.	B	Part No.	B	Part No.	E	Part No.	B	P1	P2	C
1/8"	EUS 1/8 W	20.2	RUS 1/8-5/32 W	35.2	SUS 1/8 W	34.5	TUS 1/8 W	20.2	PGS 5/32	25	5	2.5	13
5/32"	EUS 5/32 W	20.2	RUS 5/32-1/4 W	37	SUS 5/32 W	35.1	TUS 5/32 W	20.2	PGS 3/16	31	6	2.5	15
3/16"	EUS 3/16 W	22.6			SUS 3/16 W	38.05	TUS 3/16 W	22.6	PGS 1/4	33	7	3	17
1/4"	EUS 1/4 W	22.3	RUS 1/4-5/16 W	40.9	SUS 1/4 W	38.05	TUS 1/4 W	22.3	PGS 5/16	37	9	4	18
5/16"	EUS 5/16 W	23.9	RUS 5/16-3/8 W	47.05	SUS 5/16 W	42.7	TUS 5/16 W	24.1	PGS 3/8	42	11	5	23
3/8"	EUS 3/8 W	30.5	RUS 3/8-1/2 W	52	SUS 3/8 W	48.4	TUS 3/8 W	27.2	PGS 1/2	44	13	6	23
1/2"	EUS 1/2 W	32.2			SUS 1/2 W	52.5	TUS 1/2 W	31.9					
4mm	EUS 4 W	20.2	RUS 4-6 W	37	SUS 4 W	35.1	TUS 4 W	20.2	PGS 4	25	5	2.5	13
6mm	EUS 6 W	22.3	RUS 6-8 W	40.9	SUS 6 W	38.05	TUS 6 W	22.3	PGS 6	33	7	3	17
8mm	EUS 8 W	23.9	RUS 8-10 W	47.05	SUS 8 W	42.7	TUS 8 W	24.1	PGS 8	37	9	4	18
10mm	EUS 10 W	30.5	RUS 10-12 W	52	SUS 10 W	48.4	TUS 10 W	27.2	PGS 10	42	11	5	23
12mm	EUS 12 W	32.2			SUS 12 W	52.5	TUS 12 W	31.9	PGS 12	44	13	6	23

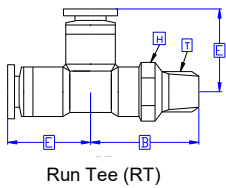

Model	Run Tee					Tube Adaptor			
	Tube OD	T, Thread	Part No.	A	B	E	Part No.	A	B
1/8	10-32	RTS 1/8 10-32W	5.4	21.85	20.2	TAS 1/8 10-32	23.4	13	S11
1/8	1/8 NPT	RTS 1/8 N1/8W	8.2	19.5	20.2	TAS 1/8 N1/8	26.2	13	S11
1/8	1/4 NPT	RTS 1/8 N1/4W	11.5	22.8	20.2	TAS 1/8 N1/4	29.5	13	S14
5/32	10-32	RTS 5/32 10-32W	5.4	21.85	20.2	TAS 5/32 10-32	25.4	15	S11
5/32	1/8 NPT	RTS 5/32 N1/8W	8.2	19.5	20.2	TAS 5/32 N1/8	28.2	15	S11
5/32	1/4 NPT	RTS 5/32 N1/4W	11.5	22.8	20.2				
3/16	1/8 NPT	RTS 3/16 N1/8W	8.2	21.3	22.6	TAS 3/16 N1/8	28.2	15	S11
3/16	1/4 NPT	RTS 3/16 N1/4W	11.5	23.9	22.6	TAS 3/16 N1/4	31.5	15	S14
1/4	10-32	RTS 1/4 10-32W	5.4	20.9	22.3	TAS 1/4 10-32	28.4	18	S11
1/4	1/8 NPT	RTS 1/4 N1/8W	8.2	21.3	22.3	TAS 1/4 N1/8	31.2	18	S11
1/4	1/4 NPT	RTS 1/4 N1/4W	11.5	23.9	22.3	TAS 1/4 N1/4	34.5	18	S14
1/4	3/8 NPT	RTS 1/4 N3/8W	12.5	24.9	22.3	TAS 1/4 N3/8	35.5	18	S18
5/16	1/8 NPT	RTS 5/16 N1/8W	8.2	22.3	24.1	TAS 5/16 N1/8	34.2	21	S11
5/16	1/4 NPT	RTS 5/16 N1/4W	11.5	24.4	24.1	TAS 5/16 N1/4	37.5	21	S14
5/16	3/8 NPT	RTS 5/16 N3/8W	12.5	25.9	24.1	TAS 5/16 N3/8	38.5	21	S18
3/8	1/8 NPT	RTS 3/8 N1/8W	8.2	24.15	27.2	TAS 3/8 N1/8	34.2	21	S11
3/8	1/4 NPT	RTS 3/8 N1/4W	11.5	27.5	27.2	TAS 3/8 N1/4	37.5	21	S14
3/8	3/8 NPT	RTS 3/8 N3/8W	12.5	27.2	27.2	TAS 3/8 N3/8	38.5	21	S18
3/8	1/2 NPT	RTS 3/8 N1/2W	15	30.1	27.2	TAS 3/8 N1/2	41	21	S22
1/2	1/4 NPT	RTS 1/2 N1/4W	11.5	32.2	31.9	TAS 1/2 N1/4	37.5	21	S14
1/2	3/8 NPT	RTS 1/2 N3/8W	12.5	29.8	31.9	TAS 1/2 N3/8	38.5	21	S18
1/2	1/2 NPT	RTS 1/2 N1/2W	15	32.3	31.9	TAS 1/2 N1/2	41	21	S22
4mm	M5	RTS 4 M5W	5.4	21.85	20.2	TAS 4 M5	25.4	15	S11
4mm	1/8 BSPT	RTS 4 R1/8W	8.2	19.5	20.2	TAS 4 R1/8	28.2	15	S11
4mm	1/4 BSPT	RTS 4 R1/4W	11.5	22.8	20.2	TAS 4 1/4	31.5	15	S14
6mm	M5	RTS 6 M5W	5.4	20.9	22.3	TAS 6 M5	28.4	18	S11
6mm	1/8 BSPT	RTS 6 R1/8W	8.2	21.3	22.3	TAS 6 R1/8	31.2	18	S11
6mm	1/4 BSPT	RTS 6 R1/4W	11.5	23.9	22.3	TAS 6 R1/4	34.5	18	S14
6mm	3/8 BSPT	RTS 6 R3/8W	12.5	24.9	22.3	TAS 6 R3/8	35.5	18	S18
8mm	1/8 BSPT	RTS 8 R1/8W	8.2	22.3	24.1	TAS 8 R1/8	34.2	21	S11
8mm	1/4 BSPT	RTS 8 R1/4W	11.5	24.4	24.1	TAS 8 R1/4	37.5	21	S14
8mm	3/8 BSPT	RTS 8 R3/8W	12.5	25.9	24.1	TAS 8 R3/8	38.5	21	S18
8mm	1/2 BSPT	RTS 8 R1/2W	15	28.4	24.1	TAS 8 R1/2	41	21	S22
10mm	1/8 BSPT	RTS 10 R1/8W	8.2	24.15	27.2	TAS 10 R1/8	34.2	21	S11
10mm	1/4 BSPT	RTS 10 R1/4W	11.5	27.5	27.2	TAS 10 R1/4	37.5	21	S14
10mm	3/8 BSPT	RTS 10 R3/8W	12.5	27.2	27.2	TAS 10 R3/8	38.5	21	S18
10mm	1/2 BSPT	RTS 10 R1/2W	15	30.1	27.2	TAS 10 R1/2	41	21	S22
12mm	1/4 BSPT	RTS 12 R1/4W	11.5	32.2	31.9	TAS 12 R1/4	37.5	21	S14
12mm	3/8 BSPT	RTS 12 R3/8W	12.5	29.8	31.9	TAS 12 R3/8	38.5	21	S18
12mm	1/2 BSPT	RTS 12 R1/2W	15	32.3	31.9	TAS 12 R1/2	41	21	S22

Units in mm

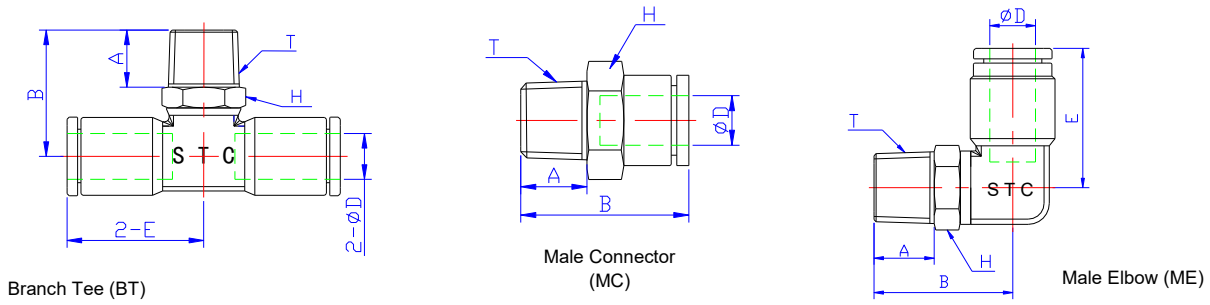

Model		Branch Tee					Male Connector				Male Elbow			
ØD	T, Thread	H	Part No.	A	B	E	Part No.	A	B	H	Part No.	A	B	E
1/8"	10-32	S11	BTS 1/8 10-32W	5.4	21.85	20.2	MCS 1/8 10-32W	4.8	23.2	S11	MES 1/8 10-32W	5.4	21.85	20.2
1/8"	1/8 NPT	S11	BTS 1/8 N1/8W	8.2	19.5	20.2	MCS 1/8 N1/8W	8	20.4	S11	MES 1/8 N1/8W	8.2	19.5	20.2
1/8"	1/4 NPT	S14	BTS 1/8 N1/4W	11.5	22.8	20.2	MCS 1/8 N1/4W	11.5	23.4	S14	MES 1/8 N1/4W	11.5	22.8	20.2
5/32"	10-32	S11	BTS 5/32 10-32W	5.4	21.85	20.2	MCS 5/32 10-32W	4.8	23.2	S11	MES 5/32 10-32W	5.4	21.85	20.2
5/32"	1/8 NPT	S11	BTS 5/32 N1/8W	8.2	19.5	20.2	MCS 5/32 N1/8W	8	20.4	S11	MES 5/32 N1/8W	8.2	19.5	20.2
5/32"	1/4 NPT	S14	BTS 5/32 N1/4W	11.5	22.8	20.2	MCS 5/32 N1/4W	11	21.5	S14	MES 5/32 N1/4W	11.5	22.8	20.2
3/16"	1/8 NPT	S11	BTS 3/16 N1/8W	8.2	21.3	22.6	MCS 3/16 N1/8W	8.2	23.6	S14	MES 3/16 N1/8W	8.2	21.3	22.6
3/16"	1/4 NPT	S14	BTS 3/16 N1/4W	11.5	23.9	22.6	MCS 3/16 N1/4W	11.5	23.6	S14	MES 3/16 N1/4W	11.5	23.9	22.6
1/4"	10-32	S12	BTS 1/4 10-32W	5.4	20.9	22.3	MCS 1/4 10-32W	4.8	25.4	S14	MES 1/4 10-32W	5.4	20.9	22.3
1/4"	1/8 NPT	S11	BTS 1/4 N1/8W	8.2	21.3	22.3	MCS 1/4 N1/8W	8.2	23.6	S14	MES 1/4 N1/8W	8.2	21.3	22.3
1/4"	1/4 NPT	S14	BTS 1/4 N1/4W	11.5	23.9	22.3	MCS 1/4 N1/4W	11.5	23.6	S14	MES 1/4 N1/4W	11.5	23.9	22.3
1/4"	3/8 NPT	S18	BTS 1/4 N3/8W	12.5	24.9	22.3	MCS 1/4 N3/8W	12	24.6	S18	MES 1/4 N3/8W	12.5	24.9	22.3
5/16"	1/8 NPT	S11	BTS 5/16 N1/8W	8.2	22.3	24.1	MCS 5/16 N1/8W	8.2	30.3	S17	MES 5/16 N1/8W	8.2	22.3	23.9
5/16"	1/4 NPT	S14	BTS 5/16 N1/4W	11.5	24.4	24.1	MCS 5/16 N1/4W	11.5	29.1	S17	MES 5/16 N1/4W	11.5	24.4	23.9
5/16"	3/8 NPT	S18	BTS 5/16 N3/8W	12.5	25.9	24.1	MCS 5/16 N3/8W	12.5	25.6	S18	MES 5/16 N3/8W	12.5	25.9	23.9
5/16"	1/2 NPT	S22					MCS 5/16 N1/2W	15	31.2	S22	MES 5/16 N1/2W	15	28.5	23.9
3/8"	1/8 NPT	S11	BTS 3/8 N1/8W	8.2	24.15	27.2	MCS 3/8 N1/8W	8.2	34.7	S18	MES 3/8 N1/8W	8.2	24.65	30.5
3/8"	1/4 NPT	S14	BTS 3/8 N1/4W	11.5	27.5	27.2	MCS 3/8 N1/4W	11.5	36.4	S18	MES 3/8 N1/4W	11.5	28	30.5
3/8"	3/8 NPT	S18	BTS 3/8 N3/8W	12.5	27.2	27.2	MCS 3/8 N3/8W	12.5	32.5	S18	MES 3/8 N3/8W	12.5	27.7	30.5
3/8"	1/2 NPT	S22	BTS 3/8 N1/2W	15	30.1	27.2	MCS 3/8 N1/2W	15	31.5	S22	MES 3/8 N1/2W	15	30	30.5
1/2"	1/4 NPT	S14	BTS 1/2 N1/4W	11.5	32.2	31.9	MCS 1/2 N1/4W	11.5	40.2	S22	MES 1/2 N1/4W	11.5	32.5	32.2
1/2"	3/8 NPT	S18	BTS 1/2 N3/8W	12.5	29.8	31.9	MCS 1/2 N3/8W	12.5	36.7	S22	MES 1/2 N3/8W	12.5	29.6	32.2
1/2"	1/2 NPT	S22	BTS 1/2 N1/2W	15	32.3	31.9	MCS 1/2 N1/2W	15	33.7	S22	MES 1/2 N1/2W	15	32.6	32.2

4	M5	S11	BTS 4 M5W	5.4	21.85	20.2	MCS 4 M5W	4.8	23.2	S11	MES 4 M5W	5.4	21.85	20.2
4	1/8 BSPT	S11	BTS 4 R1/8W	8.2	19.5	20.2	MCS 4 R1/8W	8	20.4	S11	MES 4 R1/8W	8.2	19.5	20.2
4	1/4 BSPT	S14	BTS 4 R1/4W	11.5	22.8	20.2	MCS 4 R1/4W	11.5	23.4	S14	MES 4 R1/4W	11.5	22.8	20.2
6	M5	S11	BTS 6 M5W	5.4	20.9	22.3	MCS 6 M5W	4.8	25.4	S14	MES 6 M5W	5.4	20.9	22.3
6	1/8 BSPT	S11	BTS 6 R1/8W	8.2	21.3	22.3	MCS 6 R1/8W	8.2	23.6	S14	MES 6 R1/8W	8.2	21.3	22.3
6	1/4 BSPT	S14	BTS 6 R1/4W	11.5	23.9	22.3	MCS 6 R1/4W	11.5	23.6	S14	MES 6 R1/4W	11.5	23.9	22.3
6	3/8 BSPT	S18	BTS 6 R3/8W	12.5	24.9	22.3	MCS 6 R3/8W	12	24.6	S18	MES 6 R3/8W	12.5	24.9	22.3
8	1/8 BSPT	S11	BTS 8 R1/8W	8.2	22.3	24.1	MCS 8 R1/8W	8.2	30.3	S17	MES 8 R1/8W	8.2	22.3	23.9
8	1/4 BSPT	S14	BTS 8 R1/4W	11.5	24.4	24.1	MCS 8 R1/4W	11.5	29.1	S17	MES 8 R1/4W	11.5	24.4	23.9
8	3/8 BSPT	S18	BTS 8 R3/8W	12.5	25.9	24.1	MCS 8 R3/8W	12.5	25.6	S18	MES 8 R3/8W	12.5	25.9	23.9
8	1/2 BSPT	S22	BTS 8 R1/2W	15	28.4	24.1	MCS 8 R1/2W	15	30.1	S22	MES 8 R1/2W	15	28.4	23.9
10	1/8 BSPT	S11	BTS 10 R1/8W	8.2	24.15	27.2	MCS 10 R1/8W	8.2	34.7	S18	MES 10 R1/8W	8.2	24.65	30.5
10	1/4 BSPT	S14	BTS 10 R1/4W	11.5	27.5	27.2	MCS 10 R1/4W	11.5	36.5	S18	MES 10 R1/4W	11.5	28	30.5
10	3/8 BSPT	S18	BTS 10 R3/8W	12.5	27.2	27.2	MCS 10 R3/8W	12.5	32.5	S18	MES 10 R3/8W	12.5	27.7	30.5
10	1/2 BSPT	S22	BTS 10 R1/2W	15	30.1	27.2	MCS 10 R1/2W	15	31.5	S22	MES 10 R1/2W	15	30	30.5
12	1/4 BSPT	S14	BTS 12 R1/4W	11.5	32.2	31.9	MCS 12 R1/4W	11.5	40.2	S22	MES 12 R1/4W	11.5	32.5	32.2
12	3/8 BSPT	S18	BTS 12 R3/8W	12.5	29.8	31.9	MCS 12 R3/8W	12.5	36.7	S22	MES 12 R3/8W	12.5	29.6	32.2
12	1/2 BSPT	S22	BTS 12 R1/2W	15	32.3	31.9	MCS 12 R1/2W	15	33.7	S22	MES 12 R1/2W	15	32.6	32.2

Units in mm

Ordering Part No. =
(e.g., **MCC 10 R1/8**)

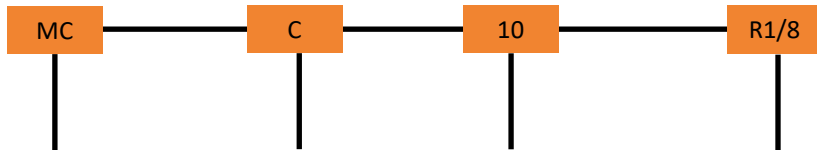

Fitting Name	
Back Ferrule	BF
Branch Tee	BT
Bulkhead Union	BU
Butt Weld	BW
Cap	CP
Cross Union	CU
Elbow Union	EU
Female Branch Tee	FB
Female Connector	FC
Front Ferrule	FF
Male Connector	MC
Male Elbow	ME
Nut	NT
Plug	PG
Reducing Union	RU
Run Tee	RT
Straight Union	SU
Tube Stem Reducer	TRC
Tee Union	TU

Material / Type	
316 Stainless Steel Double Ferrule Compression Fittings	C
316 Stainless Steel Barb Compression Fittings	A

Tube OD	
Inches	1/16
	1/8
	1/4
	5/16
	3/8
	1/2
	5/8
	3/4
mm	1
	4
	6
	8
	10
	12
	14
	16
18	
20	

Thread Size / Stem / Tube	
N = NPT	N1/8
	N1/4
	N3/8
	N1/2
	N3/4
	N1
R = PT (British Standard Pipe Taper Thread)	R1/8
	R1/4
	R3/8
	R1/2
	R3/4
Machine Thread	R1
	10-32
	M5
	M6

Features
316 Stainless Steel Compression Fittings with Double Ferrules, Compatible with Swagelok®, Parker-A-Lok, Let-Lok, Yor-Lok

Compression Fittings Specifications

Specifications	
Operating Temperature	-425 to 600 °F
Material of Construction	316 stainless steel
Compatible with	Swagelok®, Parker A-Lok, Let-Lock, Yor-Lok
Service	Air, Water, Steam, Oil, Gasoline, Natural Gas, most solvents and acids that are compatible with 316 SS







Pressure		
Tube Size (OD)		Maximum Pressure (PSI @72 °F)*
1/16"		10000
1/8"	2 mm	8800
3/16"	4 mm	5500
1/4"	6 mm	4200
5/16"	8 mm	3300
3/8"	10 mm	2800
1/2"	12 mm	2500
5/8"	16 mm	2300
3/4"	18 mm	2100
1"	20 mm	1900

* Maximum pressures are based on Type 304 and 316 annealed stainless steel welded tubing made to ASTM A213, A249, or A269 standards.

Compression Fittings List Price

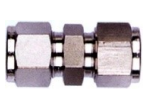



Compression Fittings													
Model		Branch Tee		Female Connector		Female Branch Tee		Male Connector		Male Elbow		Run Tee	
		BTC		FCC		FBC		MCC		MEC		RTC	
Tube OD	Thread	Part No.	Unit Price	Part No.	Unit Price	Part No.	Unit Price	Part No.	Unit Price	Part No.	Unit Price	Part No.	Unit Price
1/8"	NPT1/8"	BTC 1/8 N1/8	\$24.90	FCC 1/8 N1/8	\$12.94	FBC 1/8 N1/8	\$32.53	MCC 1/8 N1/8	\$8.39	MEC 1/8 N1/8	\$13.86	RTC 1/8 N1/8	\$25.25
1/8"	NPT1/4"	BTC 1/8 N1/4	\$28.21	FCC 1/8 N1/4	\$12.94	FBC 1/8 N1/4	\$32.53	MCC 1/8 N1/4	\$9.22	MEC 1/8 N1/4	\$13.86	RTC 1/8 N1/4	\$32.96
3/16"	NPT1/8"							MCC 3/16 N1/8	\$7.77				
1/4"	NPT1/8"	BTC 1/4 N1/8	\$24.90	FCC 1/4 N1/8	\$9.41	FBC 1/4 N1/8	\$34.08	MCC 1/4 N1/8	\$7.25	MEC 1/4 N1/8	\$19.37	RTC 1/4 N1/8	\$23.91
1/4"	NPT1/4"	BTC 1/4 N1/4	\$28.31	FCC 1/4 N1/4	\$11.52	FBC 1/4 N1/4	\$34.08	MCC 1/4 N1/4	\$7.53	MEC 1/4 N1/4	\$12.98	RTC 1/4 N1/4	\$28.31
1/4"	NPT3/8"			FCC 1/4 N3/8	\$14.74	FBC 1/4 N3/8	\$40.63	MCC 1/4 N3/8	\$9.26	MEC 1/4 N3/8	\$19.37	RTC 1/4 N3/8	\$32.96
1/4"	NPT1/2"			FCC 1/4 N1/2	\$18.18								
5/16"	NPT1/8"	BTC 5/16 N1/8	\$29.30	FCC 5/16 N1/8	\$12.03			MCC 5/16 N1/8	\$10.68	MEC 5/16 N1/8	\$19.37		
5/16"	NPT1/4"	BTC 5/16 N1/4	\$31.24	FCC 5/16 N1/4	\$12.70			MCC 5/16 N1/4	\$10.68	MEC 5/16 N1/4	\$19.37		
5/16"	NPT3/8"	BTC 5/16 N3/8	\$35.51										
3/8"	NPT1/8"			FCC 3/8 N1/8	\$12.56			MCC 3/8 N1/8	\$13.32	MEC 3/8 N1/8	\$23.84		
3/8"	NPT1/4"	BTC 3/8 N1/4	\$35.51	FCC 3/8 N1/4	\$12.56			MCC 3/8 N1/4	\$15.38	MEC 3/8 N1/4	\$23.84	RTC 3/8 N1/4	\$30.06
3/8"	NPT3/8"	BTC 3/8 N3/8	\$35.51	FCC 3/8 N3/8	\$15.91			MCC 3/8 N3/8	\$13.32	MEC 3/8 N3/8	\$32.95	RTC 3/8 N3/8	\$34.82
3/8"	NPT1/2"			FCC 3/8 N1/2	\$21.07			MCC 3/8 N1/2	\$17.85	MEC 3/8 N1/2	\$32.95		
1/2"	NPT1/4"	BTC 1/2 N1/4	\$45.13	FCC 1/2 N1/4	\$22.90	FBC 1/2 N1/4	\$70.67	MCC 1/2 N1/4	\$14.06	MEC 1/2 N1/4	\$25.88		
1/2"	NPT3/8"	BTC 1/2 N3/8	\$45.13	FCC 1/2 N3/8	\$22.90	FBC 1/2 N3/8	\$70.67	MCC 1/2 N3/8	\$14.59	MEC 1/2 N3/8	\$25.88	RTC 1/2 N3/8	\$45.08
1/2"	NPT1/2"	BTC 1/2 N1/2	\$47.43	FCC 1/2 N1/2	\$22.90	FBC 1/2 N1/2	\$70.67	MCC 1/2 N1/2	\$15.63	MEC 1/2 N1/2	\$28.69	RTC 1/2 N1/2	\$47.43
1/2"	NPT3/4"							MCC 1/2 N3/4	\$21.00	MEC 1/2 N3/4	\$41.98		





4mm	M5							MCC 4 M5	\$13.32				
4mm	R1/8							MCC 4 R1/8	\$9.72				
6mm	M5							MCC 6 M5	\$9.72	MEC 6 M5	\$19.33		
6mm	R1/8							MCC 6 R1/8	\$9.72	MEC 6 R1/8	\$15.95		
6mm	R1/4	BTC 6 R1/4	\$28.31					MCC 6 R1/4	\$9.72	MEC 6 R1/4	\$15.95		
6mm	R3/8	BTC 6 R3/8	\$28.31										
8mm	R1/8	BTC 8 R1/8	\$36.53					MCC 8 R1/8	\$9.72	MEC 8 R1/8	\$17.89		
8mm	R1/4	BTC 8 R1/4	\$36.53					MCC 8 R1/4	\$10.89	MEC 8 R1/4	\$17.89		
8mm	R3/8							MCC 8 R3/8	\$12.28	MEC 8 R3/8	\$25.88		
8mm	R1/2									MEC 8 R1/2	\$25.88		
10mm	R1/8							MCC 10 R1/8	\$8.58				
10mm	R1/4							MCC 10 R1/4	\$8.58	MEC 10 R1/4	\$18.91		
10mm	R3/8							MCC 10 R3/8	\$10.90	MEC 10 R3/8	\$18.91		
10mm	R1/2							MCC 10 R1/2	\$17.85				
12mm	R1/4	BTC 12 R1/4	\$47.58					MCC 12 R1/4	\$21.71	MEC 12 N1/4	\$30.03		
12mm	R3/8	BTC 12 R1/2	\$47.58					MCC 12 R3/8	\$21.71	MEC 12 R3/8	\$30.03		
12mm	R1/2	BTC 12 R3/8	\$47.58					MCC 12 R1/2	\$23.29	MEC 12 R1/2	\$30.03		

Compression Fittings												
	Bulkhead Union		Elbow Union		Straight Union		Tee Union		Cross Union		Reducing Union	
Model	BUC		EUC		SUC		TUC		CUC		RUC	
Tube OD	Part No.	Unit Price	Part No.	Unit Price	Part No.	Unit Price	Part No.	Unit Price	Part No.	Unit Price	Part No.	Unit Price
1/8"	BUC 1/8	\$22.94	EUC 1/8	\$20.55	SUC 1/8	\$12.84	TUC 1/8	\$24.87	CUC 1/8	\$51.39	RUC 1/8-1/16	\$16.75
1/4"	BUC 1/4	\$22.00	EUC 1/4	\$19.72	SUC 1/4	\$12.84	TUC 1/4	\$26.87	CUC 1/4	\$46.83	RUC 1/4-1/8	\$13.25
5/16"	BUC 5/16	\$22.00	EUC 5/16	\$19.72	SUC 5/16	\$12.84	TUC 5/16	\$28.41	CUC 5/16	\$46.83	RUC 5/16-1/4	\$13.25
3/8"	BUC 3/8	\$31.94	EUC 3/8	\$18.77	SUC 3/8	\$14.98	TUC 3/8	\$28.41	CUC 3/8	\$58.87	RUC 3/8-1/8	\$20.31
3/8"											RUC 3/8-1/4	\$20.31
1/2"	BUC 1/2	\$34.02	EUC 1/2	\$31.00	SUC 1/2	\$22.71	TUC 1/2	\$41.51	CUC 1/2	\$61.09	RUC 1/2-3/8	\$24.25
4 mm					SUC 4	\$12.84						
6 mm	BUC 6	\$22.94	EUC 6	\$15.77	SUC 6	\$12.84	TUC 6	\$24.87				
8 mm					SUC 8	\$12.84	TUC 8	\$26.87				
10 mm			EUC 10	\$19.72	SUC 10	\$18.86						
12 mm			EUC 12	\$34.06	SUC 12	\$22.71						

Compression Fittings														
	Cap		Back Ferrule		Front Ferrule		Nut		Plug		Tube Stem Reducer		Tube X Male Pipe (Butt Weld)	
Model	CPC		BFC		FFC		NTC		PGC		TRC		BWC	
Tube OD	Part No.	Unit Price	Part No.	Unit Price	Part No.	Unit Price	Part No.	Unit Price	Part No.	Unit Price	Part No.	Unit Price	Part No.	Unit Price
1/8"	CPC 1/8	\$7.51	BFC 1/8	\$1.43	FFC 1/8	\$2.47	NTC 1/8	\$2.47	PGC 1/8	\$7.43	TRC 1/8X1/16	\$15.78	BWC 1/8X1/8	\$7.81
1/4"	CPC 1/4	\$6.36	BFC 1/4	\$1.18	FFC 1/4	\$2.24	NTC 1/4	\$2.24	PGC 1/4	\$5.71	TRC 1/8X1/8	\$10.53	BWC 1/4X1/8	\$7.60
5/16"	CPC 5/16	\$6.77	BFC 5/16	\$1.49	FFC 5/16	\$3.79	NTC 5/16	\$3.79	PGC 5/16	\$6.61	TRC 1/8X1/4	\$10.44	BWC 1/4X1/4	\$7.96
3/8"	CPC 3/8	\$8.47	BFC 3/8	\$1.44	FFC 3/8	\$3.04	NTC 3/8	\$3.04	PGC 3/8	\$6.70	TRC 1/4X1/8	\$11.72	BWC 5/16X1/4	\$12.49
1/2"	CPC 1/2	\$12.73	BFC 1/2	\$2.03	FFC 1/2	\$4.95	NTC 1/2	\$4.95	PGC 1/2	\$9.54	TRC 1/4X1/4	\$8.19	BWC 3/8X1/4	\$12.47
											TRC 1/4X3/8	\$9.41	BWC 3/8X3/8	\$12.75
4 mm			BFC 4	\$2.08	FFC 4	\$2.24	NTC 4	\$2.24			TRC 1/4X1/2	\$11.05	BWC 3/8X1/2	\$17.55
6 mm			BFC 6	\$1.70	FFC 6	\$2.24	NTC 6	\$2.24	PGC 6	\$5.71	TRC 5/16X1/4	\$13.17	BWC 1/2X1/2	\$17.23
8 mm			BFC 8	\$2.09	FFC 8	\$3.79	NTC 8	\$3.79			TRC 3/8X1/4	\$11.66		
10 mm			BFC 10	\$1.44	FFC 10	\$4.95	NTC 10	\$4.95			TRC 3/8X3/8	\$11.35		
12 mm			BFC 12	\$2.97	FFC 12	\$4.95	NTC 12	\$4.95			TRC 3/8X1/2	\$11.66		
											TRC 1/2X1/2	\$14.27		

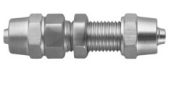
Barb Compression Fittings List Price & Specifications

Barb Compression Fittings									
Model		Male Branch Tee Swivel		Female Connector		Male Connector		Male Elbow Swivel Connector	
		BTA		FCA		MCA		MEA	
Tube OD	Thread	Part No.	Unit Price	Part No.	Unit Price	Part No.	Unit Price	Part No.	Unit Price
1/8"	N1/8								
1/8"	N1/4								
5/32"	N1/8								
5/32"	N1/4								
1/4"	N1/8	BTA 1/4 N1/8	\$32.61	FCA 1/4 N1/8	\$21.62	MCA 1/4 N1/8	\$15.73	MEA 1/4 N1/8	\$29.09
1/4"	N1/4	BTA 1/4 N1/4	\$32.61	FCA 1/4 N1/4	\$21.62	MCA 1/4 N1/4	\$15.73	MEA 1/4 N1/4	\$29.09
5/16"	N1/8								
5/16"	N1/4								
5/16"	N3/8								
3/8"	N1/4					MCA 3/8 N1/4	\$15.73		
3/8"	N3/8								
3/8"	N1/2								
1/2"	N1/4								
1/2"	N3/8								
1/2"	N1/2								

Barb Compression Fittings											
Model		Bulkhead Union		Elbow Union		Plug		Straight Union		Tee Union	
		BUA		EUA		PGA		SUA		TUA	
Tube OD		Part No.	Unit Price	Part No.	Unit Price	Part No.	Unit Price	Part No.	Unit Price	Part No.	Unit Price
1/8"											
5/32"											
1/4"		BUA 1/4	\$33.28	EUA 1/4	\$33.28	PGA 1/4	\$6.41	SUA 1/4	\$19.91	TUA 1/4	\$33.28
5/16"											
3/8"											
1/2"											

Barb Compression Fittings Specifications

Specifications	
Operating Temperature	-60 to 200°F (when used with Nylon Tubing) -350 to 500°F (when used with Teflon Tubing)
Material of Construction	316 stainless steel
Service	Air, Water, Steam, Oil, Gasoline, Natural Gas, most solvents and acids that are compatible with 316 stainless steel and the tubing material used
Maximum Pressure	800PSI @72 °F*

* Maximum pressures are based on high pressure Teflon or Nylon tubing.



Fine Quality



Precision Engineered



Advanced Design



Excellent Prices



Contents

Coil Numbering System.....	C2
Manual Valves Numbering System.....	C2
Process Valves Numbering System.....	C3 - C4
Process Valves List Price.....	C5 - C7
Coils & Digital Timers List Price.....	C8
Process Valves Specifications.....	C8 - C9
Process Valves Internal Components.....	C9
Process Valves Dimensions.....	C10 - C12
Manual Valves List Price.....	C13
Manual Valves Dimensions & Specifications.....	C13 - C14

Coil Numbering System

Ordering Part No. =
(e.g., **2W200C-1-D-13**)

2W200C — **1-D** — **13**

Coils	Model	Voltage	Wattage (W)
Coil for 2P025 & 2V Series Valves	200C	1 = 12 VDC 2 = 24 VDC	3, 4.8, 6.5
Coil for 2S/2W025-250, 3S/2W020-035 Series Valves	2W200C	2A = 24 VAC	14, 20
Coil for 2LS120-200, 2MS/2MSO120-500, 2P/2PO160-250, 2S/2W350-500, 2WO/2SO160-250 Series Valves	2WO250C	3 = 110 VAC 4 = 220 VAC (50-60 Hz)	20-30
Coil for 2L170-300, 2LS250-500, 2WO/2SO350-500 Series Valves	2W350C		25-35

Manual Valve Numbering System

Ordering Part No. =
(e.g., **V1-1/4**)

V1 — **1/4** —

Manual Ball Valves	
Reduced Port 316 SS Ball Valve (1 Piece)	V1
Full Port 316 SS Ball Valve (2 Piece)	V2
Full Port 316 SS Ball Valve (3 Piece)	V3
Full Port 316 SS Ball Valve (3 Piece, Tri-Clamp)	V3C
Reduced Port Chrome Plated Brass Ball Valve (FXF Port)	T400
Reduced Port Chrome Plated Brass Ball Valve (FXM Port)	T400FM
316 SS Needle Valve	VNO1

Port Size (NPT)
1/4
3/8
1/2
3/4
1
1 1/4
1 1/2
2

Options	
Lockable Handle	L
Panel Mount	P

Ordering Part No. =
(e.g., 2W025-1/4-1-D-V)

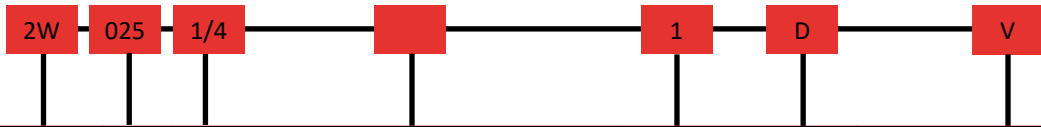

Action	Normally Closed / Normally Open	Body Material	Model Series	Orifice Size 10X (mm)	Port Size (NPT)	Material / Type (for standard materials, leave blank)	Voltage Option	Electrical Connection	Seal Options			
2 Way Direct Acting Zero Differential	NC	Stainless Steel	2H	012	1/8	Standard: Stainless Steel Body (leave blank)	1 = 12VDC 2 = 24VDC 2A = 24VAC 3 = 110VAC 4 = 220VAC (50/60Hz) E = Explosion Proof Coil	D = DIN	Standard: PTFE (leave blank) Option: V = Viton			
		Plastic	2P	025	1/8	S = Plastic Solenoid Valve w/ SS Actuator A = Acetal Plastic Solenoid Valve w/ SS Actuator		G = Grommet D = DIN	Standard: NBR (leave blank) Options: E = EPDM, V = Viton, P = PTFE (Teflon)			
					1/4			Standard: Teflon Body (leave blank)	D = DIN	Standard: Viton (leave blank) Option: E = EPDM		
		PTFE (Teflon)	2T	060	3/8							
					1/2							
					Stainless Steel	2S		025	1/8	H = 304 Stainless Steel Hex Shape Body	G = Grommet D = DIN	Standard: NBR (leave blank) Options: E = EPDM, V = Viton
								025	1/4	Standard: 304 Stainless Steel Body (leave blank) H = 304 Stainless Steel Hex Shape Body		
								035	1/4	Standard: 304 Stainless Steel Body (leave blank)		
		040	3/8									
		050	1/4									
Brass	2W	025	1/4	Standard: Brass Body (leave blank) H = Brass Hex Shape Body	G = Grommet D = DIN	Standard: NBR (leave blank) Option: V = Viton						
		035	1/4	Standard: Brass Body (leave blank)								
		040	3/8									
NO	NO	Stainless Steel	2SO	040	3/8	Standard: 304 Stainless Steel Body (leave blank)	D = DIN	Standard: NBR (leave blank) Option: V = Viton				
		Brass	2WO	040	3/8	Standard: Brass Body (leave blank)						
3 Way Direct Acting Zero Differential	NC	Plastic	3P	010	1/8	A = Acetal Delrin Plastic	D = DIN	Standard: NBR (leave blank)				
	NC or NO	Stainless Steel	3S	020	1/4				Standard: 304 Stainless Steel Body (leave blank)			
035				1/4								
2 Way Direct Lift Diaphragm Zero Differential	NC	Stainless Steel	2S	160	3/8	Standard: 304 Stainless Steel Body (leave blank)	1 = 12VDC 2 = 24VDC 2A = 24VAC 3 = 110VAC 4 = 220VAC (50/60Hz) E = Explosion Proof Coil	D = DIN	Standard: NBR (leave blank) Options: E = EPDM, V = Viton			
				160	1/2							
				200	3/4							
				250	1							
				350	1 1/4							
				400	1 1/2							
				500	2							
		Brass	2W	160	3/8	Standard: Brass Body (leave blank)		D = DIN	Standard: NBR (leave blank) Options: E = EPDM, V = Viton			
				160	1/2							
				200	3/4							
	Plastic	2P	160	1/2	Standard: Plastic Body (leave blank)	D = DIN	Standard: NBR (leave blank) Options: E = EPDM, V = Viton					
			200	3/4								
			250	1								
	NO	Stainless Steel	2SO	160	3/8	Standard: 304 Stainless Steel Body (leave blank)	D = DIN	Standard: NBR (leave blank) Options: E = EPDM, V = Viton				
				160	1/2							
				200	3/4							
				250	1							
				350	1 1/4							
				400	1 1/2							
				500	2							
Brass		2WO	160	3/8	Standard: Brass Body (leave blank)	D = DIN		Standard: NBR (leave blank) Options: E = EPDM, V = Viton				
			160	1/2								
			200	3/4								
Plastic	2PO	160	1/2	Standard: Plastic Body (leave blank)	D = DIN	Standard: NBR (leave blank) Option: V = Viton						
		200	3/4									
		250	1									



Process Valves Numbering System

Ordering Part No. =
(e.g., 2MS150-1/2-3-D)

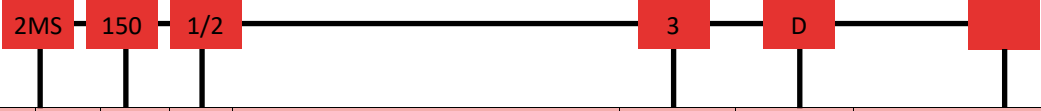

Action	Normally Closed / Normally Open	Body Material	Model Series	Orifice Size 10X (mm)	Port Size (NPT)	Material / Type (for standard materials, leave blank)	Voltage Option	Electrical Connection	Seal Options		
2 Way Pilot Piston	NC	Brass	2L	170	1/2	Standard: Brass Body (leave blank)	1 = 12VDC 2 = 24VDC 2A = 24VAC 3 = 110VAC 4 = 220VAC (50/60Hz) E = Explosion Proof Coil	D = DIN	Standard Seal: PTFE (leave blank)		
				170	3/4						
				200	1						
				300	1 1/2						
2 Way Direct Lift Piston Zero Differential	NC	Stainless Steel	2LS	120	3/8	Standard: 304 Stainless Steel (leave blank)		1 = 12VDC 2 = 24VDC 2A = 24VAC 3 = 110VAC 4 = 220VAC (50/60Hz) E = Explosion Proof Coil	D = DIN	Standard Seal: PTFE (leave blank)	
				150	1/2						
				200	3/4						
				250	1						
				320	1 1/4						
				400	1 1/2						
2 Way Pilot Diaphragm	NC	Brass	2V	130	3/8	Standard: Brass Body (leave blank)			1 = 12VDC 2 = 24VDC 2A = 24VAC 3 = 110VAC 4 = 220VAC (50/60Hz) E = Explosion Proof Coil	D = DIN	Standard Seal: NBR (leave blank) Option: V = Viton
				130	1/2						
				250	3/4						
				250	1						
2 Way Pilot Piston 7PSI Differential	NC	Stainless Steel	2MS	120	3/8	Standard: 304 Stainless Steel (leave blank)	1 = 12VDC 2 = 24VDC 2A = 24VAC 3 = 110VAC 4 = 220VAC (50/60Hz) E = Explosion Proof Coil			D = DIN	Standard Seal: PTFE (leave blank) Standard Pressure: 6 to 230PSI (leave blank) Pressure Options: M = Medium, Pressure 6 to 580PSI (DC), H = High, Pressure 87 to 1160 PSI
				150	1/2						
				200	3/4						
				250	1						
				320	1 1/4						
	NO	Stainless Steel	2MSO	120	3/8	Standard: 304 Stainless Steel (leave blank)		1 = 12VDC 2 = 24VDC 2A = 24VAC 3 = 110VAC 4 = 220VAC (50/60Hz) E = Explosion Proof Coil		D = DIN	Standard Seal: PTFE (leave blank)
				150	1/2						
				200	3/4						
				250	1						
				320	1 1/4						
2 Way, Slow Closing Pilot Diaphragm	NC (Option: NO)	Brass	2D	150	1/2	Standard: Brass (leave blank)			1 = 12VDC 2 = 24VDC 2A = 24VAC 3 = 110VAC 4 = 220VAC (50/60Hz) E = Explosion Proof Coil	D = DIN	Standard: NBR - Buna N (leave blank) Option: V = Viton, E = EPDM
				200	3/4						
				250	1						
				320	1 1/4						
				400	1 1/2						
	NO (Option: NO)	Stainless Steel	2DS	150	1/2	Standard: 304 Stainless Steel (leave blank) Option: 316 Stainless Steel	1 = 12VDC 2 = 24VDC 2A = 24VAC 3 = 110VAC 4 = 220VAC (50/60Hz) E = Explosion Proof Coil			D = DIN	Standard: NBR - Buna N (leave blank) Option: V = Viton, E = EPDM
				200	3/4						
				250	1						
				320	1 1/4						
				400	1 1/2						
2 Way, Pilot Piston	NC	Stainless Steel	2DS	500	2F	Standard: 304 Stainless Steel (leave blank)		1 = 12VDC 2 = 24VDC 2A = 24VAC 3 = 110VAC 4 = 220VAC (50/60Hz) E = Explosion Proof Coil		D = DIN	Standard: NBR - Buna N (leave blank)
				650	2 1/2F						
				800	3F						
				1000	4F						
				1500	6F						
	NO	Stainless Steel	2DSO	500	2F	Standard: 304 Stainless Steel (leave blank)			1 = 12VDC 2 = 24VDC 2A = 24VAC 3 = 110VAC 4 = 220VAC (50/60Hz) E = Explosion Proof Coil	D = DIN	Standard: NBR - Buna N (leave blank) Option: V = Viton, E = EPDM
				650	2 1/2F						
				800	3F						
				1000	4F						
				1500	6F						
2 Way Pilot Diaphragm	NC	Brass	2R	130	3/8	Standard: Brass (leave blank)	1 = 12VDC 2 = 24VDC 2A = 24VAC 3 = 110VAC 4 = 220VAC (50/60Hz) E = Explosion Proof Coil			D = DIN	Standard: NBR - Buna N (leave blank) Option: V = Viton, E = EPDM
				150	1/2						
				200	3/4						
				250	1						
				320	1 1/4						
	NO (Option: NO)	Stainless Steel	2RS	130	3/8	Standard: 316 Stainless Steel (leave blank)		1 = 12VDC 2 = 24VDC 2A = 24VAC 3 = 110VAC 4 = 220VAC (50/60Hz) E = Explosion Proof Coil		D = DIN	Standard: NBR - Buna N (leave blank) Option: V = Viton, E = EPDM
				150	1/2						
				200	3/4						
				250	1						
				320	1 1/4						
400	1 1/2										
500	2										

	Valve Type	Part No.	List Price	Voltage Options	Electrical Connection	Seal (Options)	Coil Power (W)	Cv	Orifice (mm)	Services	Features
	2 Way, NC Direct Acting Plastic Body	2P025-1/8	\$26.92	1 = 12VDC 2 = 24VDC 2A = 24VAC 3 = 110VAC 4 = 220VAC (50/60Hz)	G = Grommet D = DIN	Standard: NBR (leave blank) Options: E = EPDM, V = Viton, P = PTFE (Teflon)	3-6.5	0.23	2.5	Air	Operating Temp: -5 to 80°C Operating Pressure: Vacuum to 115PSI Coil: F Class, IP65, 100% ED
		2P025-1/4							2.5	Air, Water, Liquid	
		2P025-1/8 S	\$29.71						2	Air, Water, Liquid	
		2P025-1/4 S							2	Air, Water, Liquid	
		2P025-1/8 A	\$31.12						2	Air, Water, Liquid	
	3 Way, NC Direct Acting Plastic Body	3P010-1/8A	\$32.50	1 = 12VDC 2 = 24VDC 2A = 24VAC 3 = 110VAC 4 = 220VAC (50/60Hz)	D = DIN	Standard: NBR (leave blank)	3-6.5	0.05	1	Air, Water, Liquid	Operating Temp: 32 to 50°F Operating Pressure: Vacuum to 60PSI Coil: B Class, IP65, 100% ED
		3P010-1/4A	\$32.50						1	Air, Water, Liquid	
	2 Way, NC Direct Acting Stainless Steel Body	2S012-1/8A	\$41.47	1 = 12VDC 2 = 24VDC 2A = 24VAC 3 = 110VAC 4 = 220VAC (50/60Hz) E = Explosion Proof Coil	G = Grommet D = DIN	Standard: NBR (leave blank) Options: E = EPDM, V = Viton	3-6.5	0.05	1.2	Air, Liquid, Oil, Water	Temp: -10 to 80°C Operating Pressure: 0 to 200PSI
		2S012-1/4A	\$41.47						1.2		
		2S020-1/8A	\$41.47						2.5		
		2S020-1/4A	\$41.47						2.5		
	3 Way, Universal Direct Acting Stainless Steel Body	3S012-1/8A	\$45.65	1 = 12VDC 2 = 24VDC 2A = 24VAC 3 = 110VAC 4 = 220VAC (50/60Hz) E = Explosion Proof Coil	G = Grommet D = DIN	Standard: NBR (leave blank) Options: E = EPDM, V = Viton	3-6.5	0.05	1.2	Air, Liquid, Oil, Water	Temp: -10 to 80°C Pressure: Normally Closed: Vacuum to 60PSI Normally Open: Vacuum to 150PSI Diverter Valve 1 input to 2 outputs: Vacuum to 150PSI
		3S012-1/4A	\$45.65						1.2		
	2 Way, NC Direct Acting Stainless Steel Body	2S025-1/8H	\$41.47	1 = 12VDC 2 = 24VDC 2A = 24VAC 3 = 110VAC 4 = 220VAC (50/60Hz) E = Explosion Proof Coil	G = Grommet	Standard: NBR (leave blank)	10-14	0.23	2.5	Air, Liquid, Oil, Water	Operating Temp: -10 to 80°C Operating Pressure: Vacuum to 150PSI Coil: H Class, IP65, 100% ED
		2S025-1/4H	\$41.47						2.5		
	2 Way, NC Direct Acting Stainless Steel Body	2W025-1/4H	\$40.17	1 = 12VDC 2 = 24VDC 2A = 24VAC 3 = 110VAC 4 = 220VAC (50/60Hz) E = Explosion Proof Coil	D = DIN	Standard: NBR (leave blank) Options: E = EPDM, V = Viton	14-20	0.23	2.5	Air, Liquid, Oil, Water	Operating Temp: -10 to 80°C Operating Pressure: 2S025: Vacuum to 200PSI, 2S035: Vacuum to 170PSI, 2S040: Vacuum to 150PSI, 2S050: Vacuum to 80PSI Coil: H Class, IP65, 100% ED
		2S025-1/4	\$44.83						3.5		
		2S035-1/4	\$49.01						4		
		2S040-3/8	\$62.21						5		
		2S050-1/4	\$62.21						5		
	2 Way, NC Direct Acting Brass Body	2S050-3/8	\$62.21	1 = 12VDC 2 = 24VDC 2A = 24VAC 3 = 110VAC 4 = 220VAC (50/60Hz)	D = DIN	Standard: NBR (leave blank) Option: V = Viton	10-14	0.23	2.5	Air, Liquid, Oil, Water	Operating Temperature (with NBR seal): -10 to 80°C Operating Temperature (with Viton seal): -15 to 120°C Operating Pressure: Vacuum to 150PSI Coil: H Class, IP65, 100% ED
		2W025-1/4	\$40.17						3.5		
		2W035-1/4	\$45.73						4		
	2 Way, NC Direct Acting Stainless Steel	2W040-3/8	\$49.90	1 = 12VDC 2 = 24VDC 2A = 24VAC 3 = 110VAC 4 = 220VAC (50/60Hz)	D = DIN	Standard: PTFE/Teflon (leave blank) Option: V = Viton	14-20	0.05	1.2	Air, Water, Liquid	Operating Temp: 0 to 85°C Operating Pressure: 2H012—Vacuum to 1000PSI Coil: H Class, IP65, 100% ED
	2 Way, NO Direct Acting Stainless Steel	2H012-1/8	\$82.18	1 = 12VDC 2 = 24VDC 2A = 24VAC 3 = 110VAC 4 = 220VAC (50/60Hz)	D = DIN	Standard: NBR (leave blank) Option: V = Viton	30		3	Air, Gas, Liquid	Operating Temp: -5 to 80°C Operating Pressure: Vacuum to 90PSI Coil: H Class, IP65, 100% ED
		2S0030-1/4	\$83.22						4		
	2 Way, NO Direct Acting Brass	2S0040-3/8	\$93.23	1 = 12VDC 2 = 24VDC 2A = 24VAC 3 = 110VAC 4 = 220VAC (50/60Hz)	D = DIN	Standard: NBR (leave blank) Option: V = Viton	30	0.6	4	Air, Liquid, Oil, Water	Operating Temp (with NBR Seal): -10 to 80°C Operating Temp (with Viton Seal): -15 to 120°C Operating Pressure: Vacuum to 90PSI Coil: H Class, IP65, 100% ED
	2 Way, NC Pilot Diaphragm Brass	2W0040-3/8	\$82.99	1 = 12VDC 2 = 24VDC 2A = 24VAC 3 = 110VAC 4 = 220VAC (50/60Hz) E = Explosion Proof Coil	D = DIN	Standard: NBR (leave blank) Option: E = EPDM, V = Viton	3-6.5		4.8	Air, Liquid, Oil, Water	Operating Temp (with NBR Seal): -5 to 80°C Operating Temp (with Viton Seal): -15 to 120°C Operating Pressure: 5 to 115PSI (NBR Seal), 5 to 150PSI (Viton Seal) Coil: F Class, IP65, 100% ED
		2V130-3/8	\$85.92						4.8		
		2V130-1/2	\$85.92						25		
		2V250-3/4	\$165.68						25		
		2V250-1	\$165.68								

Process Valves List Price

	Valve Type	Part No.	List Price	Voltage Options	Electrical Connection	Seal (Options)	Coil Power (W)	Cv	Orifice (mm)	Services	Features
	3 Way, NC/NO Direct Acting Stainless Steel	3S020-1/4	\$86.21	1 = 12VDC 2 = 24VDC 2A = 24VAC 3 = 110VAC 4 = 220VAC (50/60Hz)	D = DIN	V = Viton	13-20	0.23	2	Air, Liquid, Oil, Water	Operating Temp: -15 to 120°C Operating Pressure: Vacuum to 100PSI (2mm orifice), Vacuum to 60PSI (3.5mm orifice) Coil: H Class, IP65, 100% ED
		3S035-1/4	\$86.21					0.5	3.5		
	2 Way, NC Direct Lift Diaphragm Stainless Steel Zero Differential	2S160-3/8	\$151.16	1 = 12VDC 2 = 24VDC 2A = 24VAC 3 = 110VAC 4 = 220VAC (50/60Hz) E = Explosion Proof Coil	D = DIN	Standard: NBR (leave blank) Options: E = EPDM V = Viton	14-20	4.8	16	Air, Liquid, Oil, Water	Operating Temp: -5 to 80°C (with NBR Seal), -5 to 120°C (with Viton Seal) Operating Pressure: Vacuum to 150PSI (AC Coil), Vacuum to 100PSI (DC Coil) Coil: H Class, IP65, 100% ED
		2S160-1/2	\$151.16					4.8	16		
		2S200-3/4	\$171.42					7.6	20		
		2S250-1	\$192.66					12	25		
		2S350-1 1/4	\$350.25					24	35		
		2S400-1 1/2	\$373.67					29	40		
		2S500-2	\$583.78					48	50		
	2 Way, NC Direct Lift Diaphragm Brass Zero Differential	2W160-3/8	\$87.40	1 = 12VDC 2 = 24VDC 2A = 24VAC 3 = 110VAC 4 = 220VAC (50/60Hz) E = Explosion Proof Coil	D = DIN	Standard: NBR (leave blank) Options: E = EPDM V = Viton	14-20	4.8	16	Air, Liquid, Oil, Water	Operating Temp: -5 to 80°C (with NBR Seal), -5 to 120°C (with Viton Seal) Operating Pressure: Vacuum to 150PSI (AC Coil), Vacuum to 100PSI (DC Coil) Coil: H Class, IP65, 100% ED
		2W160-1/2	\$93.66					4.8	16		
		2W200-3/4	\$101.29					7.6	20		
		2W250-1	\$128.89					12	25		
		2W350-1 1/4	\$247.34					24	35		
		2W400-1 1/2	\$284.63					29	40		
		2W500-2	\$399.23					48	50		
	2 Way, NC Direct Lift Diaphragm Plastic Zero Differential	2P160-1/2	\$64.94	1 = 12VDC 2 = 24VDC 2A = 24VAC 3 = 110VAC 4 = 220VAC (50/60Hz)	D = DIN	Standard: NBR (leave blank) Options: E = EPDM V = Viton	30	4.8	16	Air, Liquid, Oil, Water	Operating Temp: 0 to 50°C Operating Pressure: Vacuum to 90PSI Coil: H Class, IP65, 100% ED
		2P200-3/4	\$77.25					7.6	20		
		2P250-1	\$105.95					12	25		
	2 Way, NC Pilot Piston Plastic	2PO160-1/2	\$94.16	1 = 12VDC 2 = 24VDC 2A = 24VAC 3 = 110VAC 4 = 220VAC (50/60Hz)	D = DIN	Standard: NBR (leave blank) Option: V = Viton	30-35	4.8	16	Air, Liquid, Oil, Water Vacuum Reverse Flow Direction	Operating Temp: 0 to 50°C Operating Pressure: Vacuum to 90PSI Coil: H Class, IP65, 100% ED
		2PO200-3/4	\$106.48					7.6	20		
		2PO250-1	\$135.16					12	25		
	2 Way, NO Direct Lift Diaphragm Stainless Steel Zero Differential	2SO160-3/8	\$173.88	1 = 12VDC 2 = 24VDC 2A = 24VAC 3 = 110VAC 4 = 220VAC (50/60Hz)	D = DIN	Standard: NBR (leave blank) Options: E = EPDM V = Viton	30-38	4.8	16	Air, Liquid, Oil, Water	Operating Temp: 5 to 80°C (with NBR Seal), -5 to 120°C (with Viton Seal) Operating Pressure: Vacuum to 90PSI Coil: H Class, IP65, 100% ED
		2SO160-1/2	\$189.70					4.8	16		
		2SO200-3/4	\$221.36					7.6	20		
		2SO250-1	\$347.74					12	25		
		2SO350-1 1/4	\$414.67					24	35		
		2SO400-1 1/2	\$482.15					29	40		
		2SO500-2	\$657.48					48	50		
	2 Way, NO Direct Lift Diaphragm Brass Zero Differential	2WO160-3/8	\$133.80	1 = 12VDC 2 = 24VDC 2A = 24VAC 3 = 110VAC 4 = 220VAC (50/60Hz)	D = DIN	Standard: NBR (leave blank) Options: E = EPDM V = Viton	30-38	4.8	16	Air, Liquid, Oil, Water	Operating Temp: -10 to 80°C (with NBR Seal), -15 to 120°C (with Viton Seal) Operating Pressure: Vacuum to 90PSI (with NBR Seal), Vacuum to 150PSI (with Viton Seal) Coil: H Class, IP65, 100% ED
		2WO160-1/2	\$133.80					4.8	16		
		2WO200-3/4	\$145.91					7.6	20		
		2WO250-1	\$170.28					12	25		
		2WO350-1 1/4	\$299.51					24	35		
		2WO400-1 1/2	\$358.42					29	40		
		2WO500-2	\$484.90					48	50		
	2 Way, NC Pilot Piston Brass	2L170-1/2	\$189.74	1 = 12VDC 2 = 24VDC 2A = 24VAC 3 = 110VAC 4 = 220VAC (50/60Hz)	D = DIN	Standard: PTFE	30-35	4.8	17	Air, Liquid, Steam	Operating Temp: -5 to 180°C Operating Pressure: 7 to 232PSI Coil: F Class, IP65, 100% ED Installation: Vertical Coil Position, Horizontal Flow
		2L170-3/4	\$200.29					4.8	17		
		2L200-1	\$233.41					12	20		
		2L300-1 1/2	\$415.32					20	30		
	2 Way, NC Direct Lift Piston Stainless Steel Zero Differential	2LS150-1/2	\$221.36	1 = 12VDC 2 = 24VDC 2A = 24VAC 3 = 110VAC 4 = 220VAC (50/60Hz)	D = DIN	Standard: PTFE	15	4.5	15	Steam, Air, Inert Gases, Water, Liquid	Fluid Temp: -20 to 180°C Operating Pressure: 0 to 120PSI (AC Coil), 0 to 80PSI (DC Coil) Coil: H Class, IP65, 100% ED
		2LS200-3/4	\$273.29					8.5	20		
		2LS250-1	\$341.54					12	25		
		2LS320-1 1/4	\$448.30					24	35		
		2LS400-1 1/2	\$496.32					29	40		
		2LS500-2	\$716.83					48	50		

	Valve Type	Part No.	List Price	Voltage Options	Electrical Connection	Seal (Options)	Coil Power (W)	Cv	Orifice (mm)	Services	Features
	2 Way, NC Pilot Piston Stainless Steel	2MS120-3/8	\$202.39	1 = 12VDC 2 = 24VDC 2A = 24VAC 3 = 110VAC 4 = 220VAC (50/60Hz) E = Explosion Proof Coil	D = DIN	Standard: PTFE (Teflon)	13-20	4.5	12	Air, Liquid, Steam	Operating Temp: -20 to 180°C Operating Pressure, Standard: 6 to 230PSI Options: Medium: 6 to 580PSI (DC) Medium: 6 to 725PSI (AC) High: 87 to 1160PSI Coil: H Class, IP65, 20W, CE
		2MS150-1/2	\$202.39					4.5	15		
		2MS200-3/4	\$242.45					7.6	20		
		2MS250-1	\$309.93					12	25		
		2MS320-1 1/4	\$438.52					22	32		
		2MS400-1 1/2	\$460.66					30	40		
	2MS500-2	\$714.72	48	50							
	2 Way, NO Pilot Piston Stainless Steel	2MSO120-3/8	\$247.73	1 = 12VDC 2 = 24VDC 2A = 24VAC 3 = 110VAC 4 = 220VAC (50/60Hz)	D = DIN	Standard: PTFE (Teflon)	13-20	4.5	12	Steam, Air, Inert Gases, Water, Liquid	Fluid Temp: -20 to 180°C Ambient Temp: -20 to 55°C Operating Pressure: 6 to 145PSI Coil: H Class, IP65, 20W, CE
		2MSO150-1/2	\$247.73					4.5	15		
		2MSO200-3/4	\$287.78					7.6	20		
		2MSO250-1	\$355.25					12	25		
		2MSO320-1 1/4	\$483.86					22	32		
2MSO400-1 1/2		\$505.99	30					40			
2MSO500-2	\$760.05	48	50								
	2 Way, NC High Pressure Stainless Steel Valve	2E100-3/8	\$562.51	1 = 12VDC 2 = 24VDC 2A = 24VAC 3 = 110VAC 4 = 220VAC (50/60Hz) E = Explosion Proof Coil	D = DIN	Standard: PTFE (Teflon)	13-28	4	10	Air, Liquid, Steam	Operating Pressure: 87 to 1450PSI (Option: 87 to 2300PSI) Fluid Temperature: -40 to 180°C Coil: H Class, IP65, 20-25W, CE
		2E150-1/2	\$701.30					9.2	15		
		2E200-3/4	\$843.03					16	20		
		2E250-1	\$932.15					24	25		
	Teflon Diaphragm Isolated Teflon Direct Acting Solenoid Valve	2T060-3/8	\$374.03	2 = 24VDC 3 = 110VAC 4 = 220VAC (50/60Hz)	D = DIN	Standard: V = FKM (Viton)	20-30	2.8	6	Air, Inert Gases, Water, Liquid	Fluid Temperature: 0 to 80°C Operating Pressure: 0 to 22PSI
		2T060-1/2	\$374.03								
	2 Way, NC Slow Closing Pilot Diaphragm (NO Option)	2D150-1/2	\$104.47	1 = 12VDC 2 = 24VDC 2A = 24VAC 3 = 110VAC 4 = 220VAC (50/60Hz)	D = DIN	Standard: NBR (Buna N) Option: V = Viton, E = EPDM	12-20	3.7	15	Air, Liquid, Oil, Water	Media Temp: 14 to 176°F (14 to 266°F for Viton) Ambient Temp: 23 to 110°F Pressure: 4 to 175PSI Coil: H Class, IP65
		2D200-3/4	\$129.69					7	20		
		2D250-1	\$165.32					11.1	25		
		2D320-1 1/4	\$263.07					14	32		
		2D400-1 1/2	\$341.34					24.5	40		
		2D500-2	\$439.94					35	50		
	2 Way, NC Pilot Diaphragm Stainless Steel Valve	2DS150-1/2	\$119.96	1 = 12VDC 2 = 24VDC 2A = 24VAC 3 = 110VAC 4 = 220VAC (50/60Hz)	D = DIN	Standard: NBR (Buna N) Options: E = EPDM, V = Viton	12-20	3.7	15	Water, Air, Oil, Gas	Body: 304 Stainless Steel (Option: 316SS) Media Temp: 14 to 176°F (14 to 266°F Viton) Ambient Temp: 23 to 110°F Pressure: 4 to 175PSI Coil: H Class, IP65
		2DS200-3/4	\$145.79					7	20		
		2DS250-1	\$207.90					11.1	25		
		2DS320-1 1/4	\$309.94					14	32		
		2DS400-1 1/2	\$381.06					24.5	40		
		2DS500-2	\$497.51					35	50		
	2 Way, NC Pilot Diaphragm Flanged Stainless Steel Valve	2DS500-2F	\$861.33	1 = 12VDC 2 = 24VDC 2A = 24VAC 3 = 110VAC 4 = 220VAC (50/60Hz)	D = DIN	NBR (Buna N)	13-20	30	50	Air, Liquid	Body: 304 Stainless Steel Operating Temp: -5 to 80°C Pressure: 6 to 175PSI Maximum Pressure: 175PSI at 72°F Coil: H Class, IP65, 20W, CE
		2DS650-2 1/2F	\$1,822.18					53	65		
		2DS800-3F	\$2,098.27					82	80		
		2DS1000-4F	\$3,136.35					128	100		
		2DS1500-6F	\$6,109.96					292	150		
			2 Way, NO Pilot Piston Stainless Steel Valve					2DSO500-2F	\$905.56		
2DSO650-2 1/2F	\$1,866.34			53	65						
2DSO800-3F	\$2,142.42			82	100						
2DSO1000-4F	\$3,136.35			128	100						
2DSO1500-6F	\$6,188.58			292	150						
	2 Way, NC Pilot Diaphragm Brass Body (NO Option)	2R130-3/8	\$91.23	3 = 110VAC Option: E = Explosion Proof	D = DIN	Standard: NBR (Buna N) Options: V = Viton, E = EPDM	12-20	4.5	13	Air, Gas, Liquid, Oil, Water	Body: Brass Media Temp: 14 to 176°F Ambient Temp: 23 to 110°F Pressure: 7 to 188PSI Coil: H Class, IP65
		2R150-1/2	\$104.47					4.5	15		
		2R200-3/4	\$129.69					7.6	20		
		2R250-1	\$165.32					12	25		
		2R320-1 1/4	\$263.07					22	32		
		2R400-1 1/2	\$341.34					30	40		
2R500-2	\$439.94	48	50								
	2 Way, NC Pilot Diaphragm Stainless Steel Body (NO Option)	2RS130-3/8	\$128.18	2 = 24VDC 3 = 110VAC	D = DIN	Standard: NBR (Buna N) Option: V = Viton, E = EPDM	12-20	4.5	13	Air, Gas, Liquid, Oil, Water	Body: 316 Stainless Steel Media Temp: 14 to 176°F (14 to 266°F Viton) Ambient Temp: 23 to 110°F Pressure: 7 to 188PSI Coil: H Class, IP65
		2RS150-1/2	\$128.18					4.5	15		
		2RS200-3/4	\$145.79					7.6	20		
		2RS250-1	\$207.90					12	25		
		2RS320-1 1/4	\$309.94					22	32		
		2RS400-1 1/2	\$381.06					30	40		
2RS500-2	\$497.51	48	50								

Process Valves, Coils & Digital Timers

List Price | Process Valve Specifications

	Part No.	List Price	Options	Electrical Connection	Power	Applications
	200C	\$11.59		D = DIN (with LED indicator) G = Grommet (12" Lead Wire) F Class Insulation, IP65	3 to 6.5W	For 2P025-35, 2V, 2V1, and 3V1 Series Valves
	2W200C	\$33.76	1 = 12VDC 2 = 24VDC 2A = 24VAC 3 = 110VAC 4 = 220VAC (50/60Hz)	H Class Insulation, IP 65 Duty Cycle: 100% ED	12 to 20W	For 2S/2W025-250 Series Valves
	2WO250C	\$52.24			20 to 30W	For 2WO/2SO160-250 Series Valves
	2W350C	\$52.24			25 to 35W	For 2WO/2SO350-500 Series Valves
	2W250C-DIN-1/2M	\$8.04			0.5 Meter Long Cable	Molded Cable with DIN 43650 Form A Plug
	2W250C-DIN-1M	\$9.49	1 Meter Long Cable			
	2W250C-DIN-2M	\$12.25	2 Meter Long Cable			
	200C	\$125.35	1E = 12VDC 2E = 24VDC 2AE = 24VAC 3E = 110VAC 4E = 220VAC (50/60Hz)	Explosion Proof Coil Option: All voltages with 1/2" NPT conduit connection FM Approved. CL. I; ZONE 1, CL. I; DIV. 1; GR. A, B, C, D CL. II; GR. E, F, G CL. III T4 Ta = -20°C...+60°C		Insulation: F Class IP65 Duty Cycle: 100% ED FM Certification
	2W200C-T	\$36.52	24-240VDC or AC 50/60HZ, 1A	ON/OFF Timer Switch ON/OFF Adjustment Duration: On: 0.5 seconds to 10 seconds, Off: 30 seconds to 45 minutes. 24-240V DC or AC 50/60HZ, 1A, DIN43650A Connection for 2W200C, 2W350C, 2WO coils		
	2W200C-T-D	\$59.90	24-240V DC or AC 50/60HZ, 1A	DIGITAL ON/OFF Timer Switch ON/OFF Adjustment Duration: On: 0.5 seconds to 10 seconds, Off: 0.5 seconds to 45 minutes. Size: 88 X 48 X 21 (mm) 24-240V DC or AC 50/60HZ, 1A Termination: DIN43650A Protection: IP65, EN60529 for 2W200C, 2W350C, 2WO coils		
	2W200C-T-DH	\$75.18	110-220VAC 50/60HZ, 1A	PROGRAMMABLE DIGITAL ON/OFF Timer Switch On/OFF Single or Multi Cycles Adjustment Duration: On: 1 seconds to 99 hours, Off: 1 seconds to 99 hours. Size: 88 X 48 X 21 (mm) Termination: DIN43650A Protection: IP65, EN60529 for 2W200C, 2W350C, 2WO coils		
	2W200C-T-DL		7-36V DC or AC, 3A			
	2W200C-PS-H	\$14.47	100-280 VAC 50/60HZ, 1A	POWER SAVE DEVICE High Power Start Up Time: 0.3—2.5 seconds Energy Save Rate: 15 to 85% Power Up Grade: 20 to 300% (AC only) Size: 88 X 48 X 21 (mm) Termination: DIN43650A Protection: IP65, EN60529 for 2W200C, 2W350C, 2WO coils		
	2W200C-PS-L		12-36V DC or AC, 2A			

Valve Model	2H012 to 2H016	2L	2LS	2MS	2MSO	2P025	3P010	2S025 to 2S050	2S160 to 2S500
Valve Type	2 Way	2 Way	2 Way	2 Way	2 Way	2 Way	3 Way	2 Way	2 Way
Normally Closed (NC)	NC	NC	NC	NC	NC	NC	NC	NC	NC
Normally Open (NO)	Direct	Pilot	Direct Lift	Pilot	Pilot	Direct	Direct	Direct Acting	Direct Lift Diaphragm
Operating Pressure (PSI)	0 to 1000	7 to 232	0 to 120	6 to 230	6 to 230	0 to 115	0 to 60	0 to 200	0 to 150
Operating Temperature (°C)	-20 to 85	-5 to 180	-20 to 180	-20 to 180	-20 to 180	-5 to 80	-5 to 80	-10 to 80	-5 to 80
Ambient Temperature (°C)	-20 to 55	-5 to 50	-5 to 50	-20 to 55	-20 to 55				-5 to 45
Port Size (NPT)	1/8	1/2 to 1 1/2	3/8 to 2	3/8 to 2	3/8 to 2	1/8 to 1/4	1/8 to 1/4	1/4 to 3/8	3/8 to 2
Body Materials	Stainless Steel	Brass	Stainless Steel	Stainless Steel	Stainless Steel	Engineered Plastic	Engineered Plastic	Stainless Steel	Stainless Steel
Seal Materials	PTFE/Teflon	PTFE/Teflon	PTFE/Teflon	PTFE/Teflon	PTFE/Teflon	NBR	NBR	NBR	NBR
Coil Protection Insulation Class	H Class IP65	H Class, IP65	H Class, IP65	H Class, IP65	H Class, IP65	F Class IP65	B Class, IP65	H Class, IP65	H Class, IP65
Coil Duty	100% ED	100% ED	100% ED	100% ED	100% ED	100% ED	100% ED	100% ED	100% ED
Coil Power	14W	30-40W	30W	13-20W	20W	6.5W	6.5W	14-20W	14-35W
Electrical Connections	DIN	DIN	DIN	DIN	DIN	DIN	DIN	DIN	DIN
Services	Air, Water, Liquid	Air, Liquid, Steam		Air, Inert Gas, Liquid, Steam, Vacuum		Air, Water, Liquid		Air, Liquid, Oil, Water	

Valve Model	2SO160 to 2SO500	3SO20 to 3SO35	2T	2V025	2V130 to 2V250	2W025 to 2W040	2W160 to 2W500	2WO160 to 2WO500
Valve Type	2 Way	3 Way	2 Way	2 Way	2 Way	2 Way	2 Way	2 Way
Normally Closed (NC)	NO	NC/NO	NC	NC	NC	NC	NC	NO
Normally Open (NO)	Direct Lift Diaphragm	Direct Acting	Direct Lift Diaphragm	Direct Acting	Pilot Diaphragm	Direct Acting	Direct Lift Diaphragm	Direct Lift Diaphragm
Operating Pressure (PSI)	0 to 90	0 to 100	0 to 22	0 to 115	5 to 115	0 to 150	0 to 150	0 to 90
Operating Temperature (°C)	-5 to 80	-15 to 120	-20 to 180	-5 to 80	-5 to 80	-10 to 80	-10 to 80	-10 to 80
Ambient Temperature (°C)	-5 to 45		-20 to 55					
Port Size (NPT)	3/8 to 2	1/4	1/4 to 1/2	1/8 to 1/4	3/8 to 1	1/4 to 3/8	3/8 to 2	3/8 to 2
Body Materials	Stainless Steel	Stainless Steel	Teflon	Aluminum	Brass	Brass	Brass	Brass
Seal Materials	NBR	NBR	Viton	NBR	NBR	NBR	NBR	NBR
Coil Protection Insulation Class	H Class, IP65	H Class, IP65	H Class, IP65	F Class, IP65	F Class, IP65	H Class, IP65	H Class, IP65	H Class, IP65
Coil Duty	100% ED	100% ED	100% ED	100% ED	100% ED	100% ED	100% ED	100% ED
Coil Power	30-38W	13 to 20W	20W	6.5W	3 to 6.5W	12 to 20W	14 to 35W	30 to 38W
Electrical Connections	DIN	DIN	DIN	DIN	DIN	DIN	DIN	DIN
Services	Air, Liquid, Oil, Water		Air, Inert Gases, Water, Liquid	Air, Vacuum	Air, Liquid, Oil, Water	Air, Liquid, Oil, Water		

Process Valves Internal Components

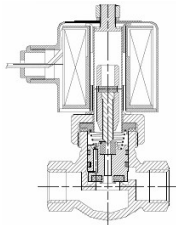
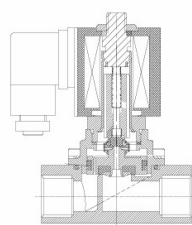
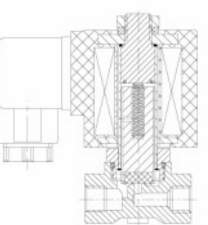
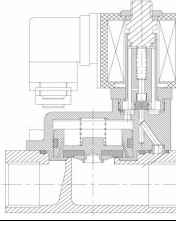
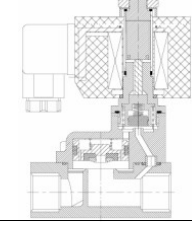
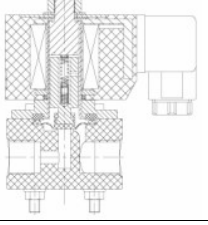
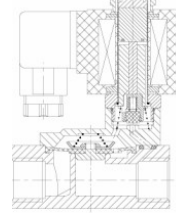
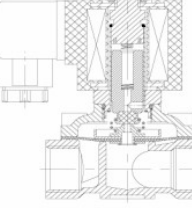
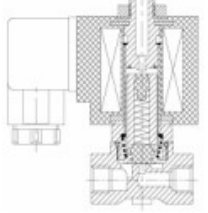
2L: Brass 2 Way NC Direct Lift Piston		2LS: Stainless Steel 2 Way NC Direct Lift Piston		2H: Stainless Steel 2P: Plastic 2V: Aluminum 2S/25-050: SS 2W/25-040: Brass 2 Way NC Direct Acting	
2MS: Stainless Steel 2 Way NC Pilot Piston		2MSO: Stainless Steel 2 Way NO Pilot Piston		2T: Teflon 2 Way NC Direct Lift Diaphragm	
2V130: Brass 2 Way NC Pilot Diaphragm		2W/2WO160-500: Brass 2S/2SO160-500: SS 2 Way NC Direct Lift Diaphragm		3W: Brass 3 Way NC Direct Acting	

Valve Components	Materials	Seal Options	Temperature Range/Compatibility
Body	Options: Aluminum, Brass, Plastic, Stainless Steel, Teflon	NBR	-10 ~ 90°C, Oil-resistant and petroleum-resistant, not good for oxygen
Armature Tube	Stainless Steel 304	EPDM	-30 ~ 130°C, Withstand ozone, resistant to corrosive chemical materials, not suitable for oil
Plunger	Stainless Steel 430F	PTFE	-20 ~ 200°C, Resistant to most chemicals, except compound with oxygen
Head	Stainless Steel 430F	VITON	-10 ~ 150°C, Resistant to most chemicals
Springs	Stainless Steel 304		
Shading Rings	Brass (Option: Silver, Nickel Plated)		

Process Valves Dimensions

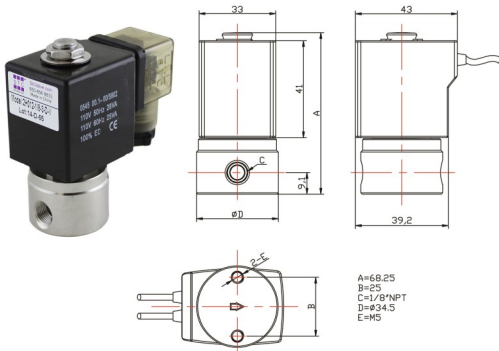

High Pressure Stainless Steel Solenoid Valve Specifications & Dimensions (mm)										
Model	Port	Cv (Orifice)	A	B	C	D	E	F	Pressure	Temperature
2H012	1/8"	0.05 (1.2MM)	65.5	30	1/8"	17	15.5	M4	0-1000 PSI	0-85°C
2H016	1/8"	0.085 (1.6MM)	65.5	30	1/8"	17	15.5	M4	0-500 PSI	0-85°C

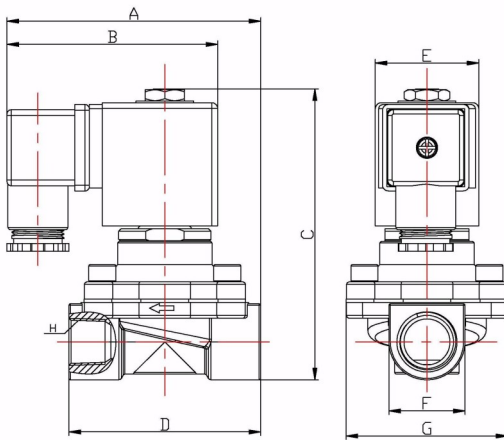
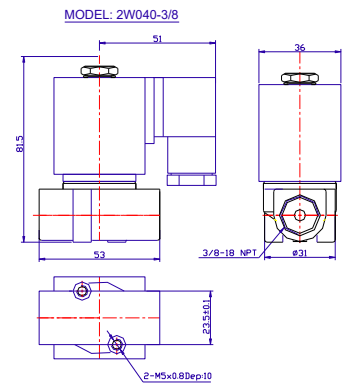
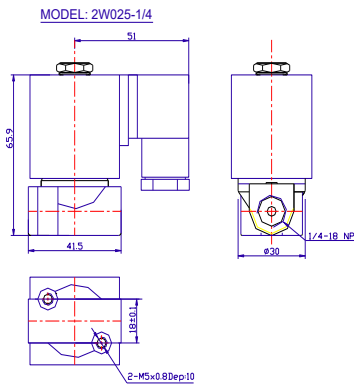
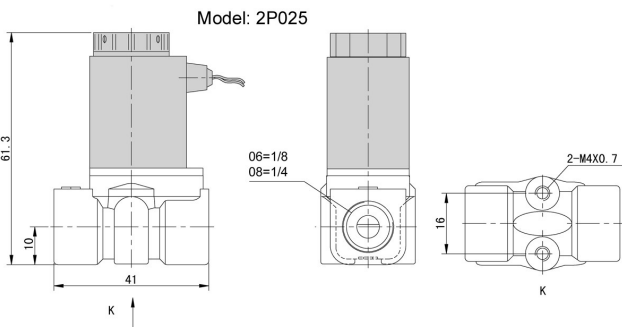

Model: 2S & 2W Series (mm)							
Model	A	B	C	D	E	F	G
2S160-3/8	2W160-3/8	101.5	57	117	69	50	36
2S160-1/2	2W160-1/2	101.5	57	117	69	50	36
2S200-3/4	2W200-3/4	107.0	57	124	73	50	36
2S250-1	2W250-1	111.5	74	135	99	50	36
2S350-1 1/4	2W350-1 1/4	142.0	95	172	123	70.5	56
2S400-1 1/2	2W400-1 1/2	142.0	95	172	123	70.5	56
2S500-2	2W500-2	172.0	123	209	168	70.5	56

MODEL: 2W & 2S 160-500 SERIES VALVES UNIT IN MM (NOT TO SCALE)

MODEL: 2L Series

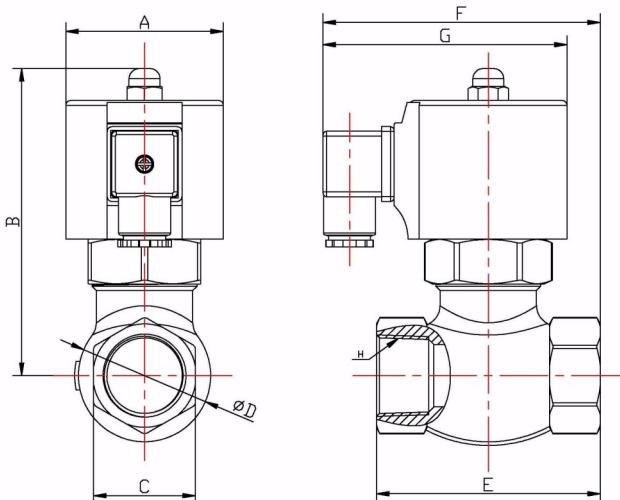

Model: 2L Series Dimensions (mm)							
Model	Port Size H (NPT)	A	B	C (hex)	E	F	G
2L170-3/8	3/8	63	125	25.4	82	109	99
2L170-1/2	1/2	63	125	29.5	82	109	99
2L170-3/4	3/4	63	125	35	82	109	99
2L200-1	1	63	125	41	91	113	99
2L300-1 1/2	1 1/2	63	145	55	112	124	99
2L500-2	2	63	183	72	165	150	99

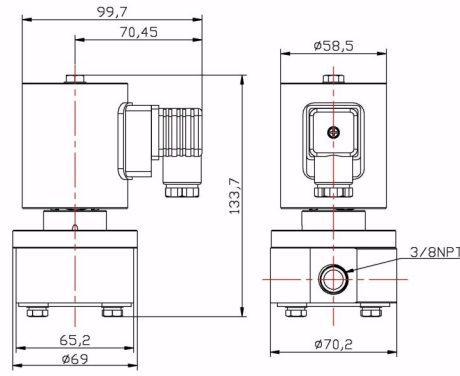
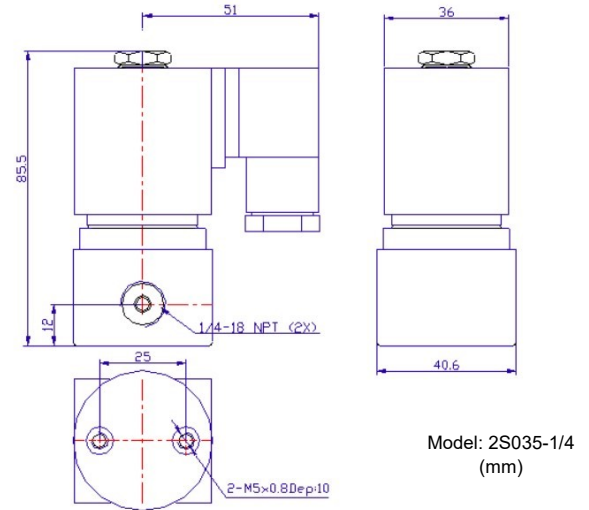
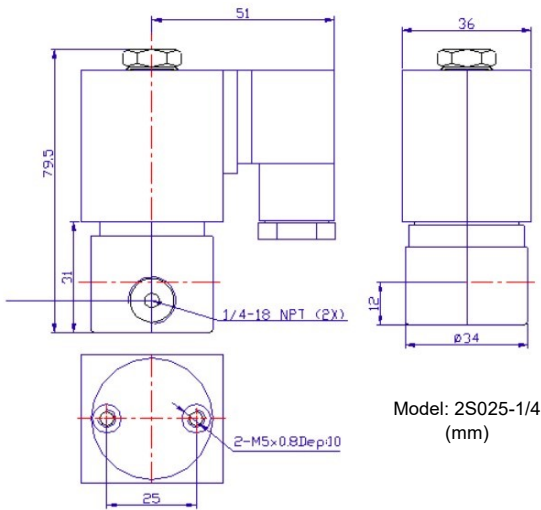

Models: 2D & 2DS Series Dimensions (mm)							
Brass	Stainless Steel	Port Size (NPT)	Orifice (mm)	Cv (mm)	L (mm)	H (mm)	H1 (mm)
2D150-1/2	2DS150-1/2	1/2	15	3.73	80	105	93
2D200-3/4	2DS200-3/4	3/4	20	7	87	114	98
2D250-1	2DS250-1	1	25	11	108	122	100
2D320-1 1/4	2DS320-1 1/4	1 1/4	32	14	130	131	107
2D400-1 1/2	2DS400-1 1/2	1 1/2	40	24.5	145	142	116
2D500-2	2DS500-2	2	50	35	177	155	123

2D & 2DS — 2 Way Slow Closing Pilot Diaphragm

Models: 2R & 2RS Series Dimensions (mm)							
Brass	Stainless Steel	Port Size (NPT)	Orifice (mm)	Cv (mm)	L (mm)	H (mm)	H1 (mm)
2R150-3/8	2RS150-3/8	3/8	13	4.5	66.5	112.5	96.5
2R150-1/2	2RS150-1/2	1/2	15	4.5	66.5	112.5	96.5
2R200-3/4	2RS200-3/4	3/4	20	7.6	75	118	98
2R250-1	2RS250-1	1	25	12	96	124.5	104.5
2R320-1 1/4	2RS320-1 1/4	1 1/4	35	22	131	137	112
2R400-1 1/2	2RS400-1 1/2	1 1/2	40	30	131	150	130
2R500-2	2RS500-2	2	50	48	165	167	130

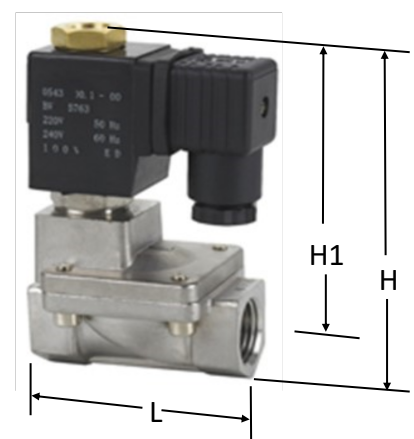

Process Valves Dimensions

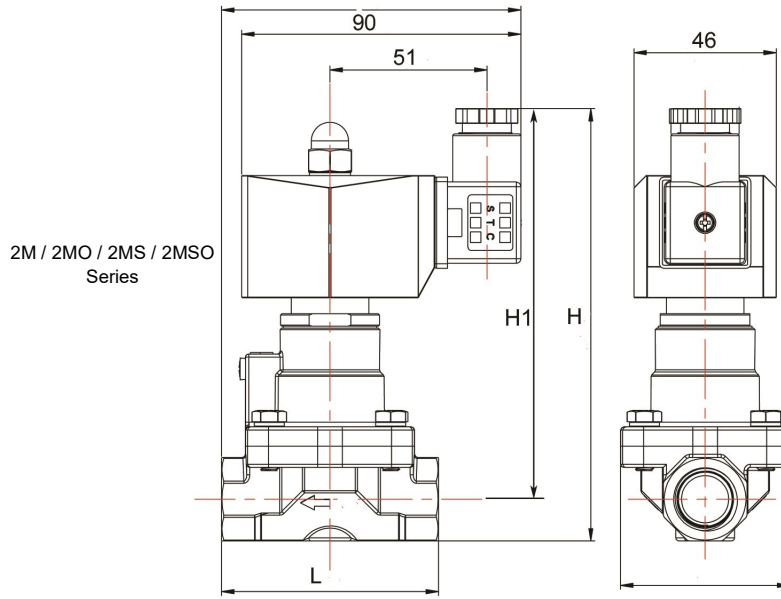

Model: 2M Series Dimensions (MM)														
Normally Closed (NC)		Normally Open (NO)		Port Size H (NPT)	Orifice	Cv	L	H1	H	Pressure (psi)		Medium Temperature	Ambient Temperature	Power Consumption
Brass	Stainless Steel	Brass	Stainless Steel							NC	NO			
2M150-1/2	2MS150-1/2	2MO150-1/2	2MSO150-1/2	1/2	15	4.5	75	117	140	6 to 230	6 to 145	-4 to 356°F	-4 to 122°F	20-30W
2M200-3/4	2MS200-3/4	2MO200-3/4	2MSO200-3/4	3/4	20	7.6	75	122	147	6 to 230	6 to 145	-4 to 356°F	-4 to 122°F	20-30W
2M250-1	2MS250-1	2MO250-1	2MSO250-1	1	25	12	92	143	155	6 to 230	6 to 145	-4 to 356°F	-4 to 122°F	20-30W
2M320-1 1/4	2MS320-1 1/4	2MO320-1 1/4	2MSO320-1 1/4	1 1/4	32	22	110	143	155	6 to 230	6 to 145	-4 to 356°F	-4 to 122°F	20-30W
2M400-1 1/2	2MS400-1 1/2	2MO400-1 1/2	2MSO400-1 1/2	1 1/2	40	30	122	145	160	6 to 230	6 to 145	-4 to 356°F	-4 to 122°F	20-30W
2M500-2	2MS500-2	2MO500-2	2MSO500-2	2	50	48	161	157	179	6 to 230	6 to 145	-4 to 356°F	-4 to 122°F	20-30W

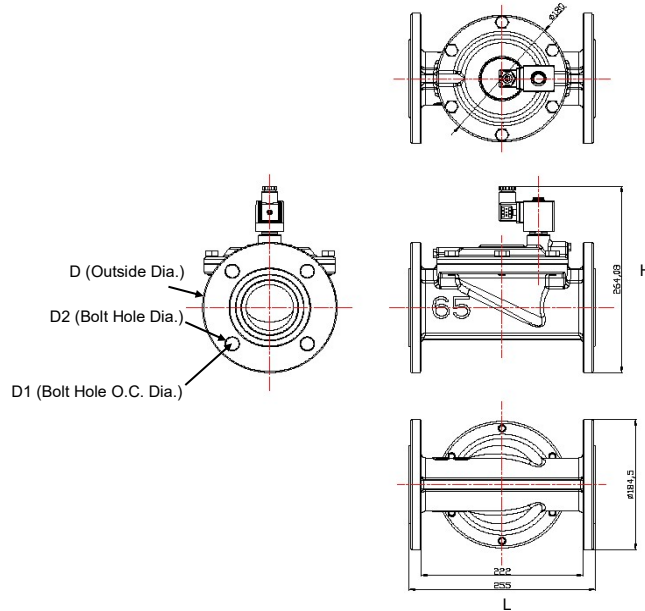

Model: 2DS Series Valves Dimensions (MM)										
Normally Closed	Normally Open	Port Size	Orifice	Cv	D (OD)	D1 (OC)	D2 (Thread Hole Dia)	L	H	H1
2DS400F-1 1/2	2DSO400F-1 1/2	1 1/2	40	21	150	110	18 (4x)	182	196	125
2DS500F-2	2DSO500F-2	2	50	30	165	125	18 (4x)	215	200	120
2DS650F-2 1/2	2DSO650F-2 1/2	2 1/2	65	52.5	185	145	18 (4x)	256	280	185
2DS800F-3	2DSO800F-3	3	800	81.7	200	160	18 (8x)	277	287	190
2DS1000F-4	2DSO1000F-4	4	100	128.4	220	180	18 (8x)	350	330	230
2DS1250F-4	2DSO1250F-4	5	125	221.7	250	210	18 (8x)	425	437	310
2DS1500F-4	2DSO1500F-4	6	150	291.7	285	240	22 (8x)	450	460	318
2DS2000F-4	2DSO2000F-4	8	200	513.5	340	295	22 (12x)	560	547	380

Model	Reduced Port Ball Valves V1		Full Port Ball Valves V2		Full Port Ball Valves V3		Full Port Ball Valves V3C	
Material	316SS		316SS		316SS		316SS	
Port	FNPT		FNPT		FNPT		Clamp	
Size	Part No.	List Price	Part No.	List Price	Part No.	List Price	Part No.	List Price
1/4"	V1-1/4	\$13.93	V2-1/4	\$26.84	V3-1/4	\$32.47		
3/8"	V1-3/8	\$13.93	V2-3/8	\$26.84	V3-3/8	\$32.47		
1/2"	V1-1/2	\$15.39	V2-1/2	\$34.26	V3-1/2	\$38.48		
3/4"	V1-3/4	\$22.38	V2-3/4	\$40.05	V3-3/4	\$48.98		
1"	V1-1	\$28.89	V2-1	\$59.99	V3-1	\$66.15	V3C-1	\$120.23
1 1/4"	V1-1 1/4	\$42.47	V2-1 1/4	\$88.65	V3-1 1/4	\$100.39		
1 1/2"	V1-1 1/2	\$58.00	V2-1 1/2	\$126.63	V3-1 1/2	\$138.80	V3C-1 1/2	\$237.05
2"	V1-2	\$83.26	V2-2	\$154.19	V3-2	\$187.22	V3C-2	\$295.34
2 1/2"					V3-2 1/2	\$389.61	V3C-2 1/2	\$513.04
3"					V3-3	\$810.90	V3C-3	\$891.10
4"					V3-4	\$1,074.22	V3C-4	\$1,472.96

Model	Miniature Ball Valves T400		Miniature Ball Valves T400FM		Needle Valves VNO1	
Material	Chrome-Plated Brass		Chrome-Plated Brass		316SS	
Port	FNPT		F x M NPT		FNPT	
Size	Part No.	List Price	Part No.	List Price	Part No.	List Price
1/8"					VNO1-1/8	\$51.77
1/4"	T400 1/4	\$5.26	T400FM-1/4	\$5.26	VNO1-1/4	\$51.77
3/8"	T400 3/8	\$5.40	T400FM-3/8	\$5.40	VNO1-3/8	\$51.77
1/2"	T400 1/2	\$6.76	T400FM-1/2	\$6.76	VNO1-1/2	\$59.00
3/4"					VNO1-3/4	\$83.29
1"					VNO1-1	\$112.86

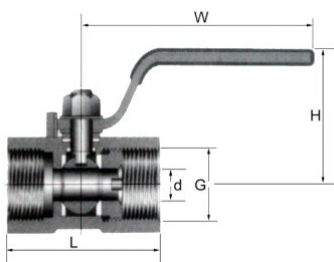

V1 Valve Specifications	
One Piece Reduced Port 316 Stainless Steel Ball Valve	
Maximum Operating Pressure: 1000 PSIG @ 100°F WOG*	
Operating Temperature Range: -60 to 450°F	
End Connections: NPT Threaded with Padlocking Device	

Dimensions (mm)						
Size	d	L	H	W	Wt (kg)	
1/4"	5	39	35	64	0.07	
3/8"	7	44	37	70	0.1	
1/2"	9.2	56.5	43.5	90	0.16	
3/4"	12.5	58	47	90	0.25	
1"	15	70	50	103	0.43	
1 1/4"	20	78	57	103	0.7	
1 1/2"	24.5	83	69	127	0.83	
2"	32	100	74.5	127	1.5	

Main Parts and Materials			
No	Part Name	Material	Qty
1	Seat	PTFE	2
2	Ball	SS316	1
3	Joint Gasket	PTFE	1
4	Cap	SS316	1
5	Body	SS316/CF8M	1
6	Stem	SS316	1
7	Thrust Washer	PTFE	1
8	Stem Packing	PTFE	1
9	Gland Nut	SS304	1
10	Stem Washer	SS304	1
11	Stem Nut	SS304	1
12	Handle Cover	PLASTIC	1
13	Handle	SS304	1

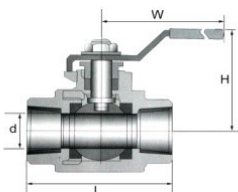

V2 Valve Specifications	
Two Piece Full Port 316 Stainless Steel Ball Valve	
Maximum Operating Pressure: 1/4" to 2" 1000 PSIG @ 100°F WOG*	
2 1/2" to 3" 800 PSIG @ 100°F WOG*	
Temperature Range: -60 to 450°F	
End Connections: NPT Threaded with Padlocking & Panel Mount Device	

Dimensions (mm)										
Size	1/4"	3/8"	1/2"	3/4"	1"	1 1/4"	1 1/2"	2"	2 1/2"	3"
d	11.6	12.7	15	20	25.4	32	38	50.8	65	76
L	55	55	63.5	75	88	103	110	124	167	192
H	48	48	50	57	69	73	83	92	136	149
W	103	103	103	125	145	145	190	190	250	250

Main Parts and Materials			
No	Part Name	Material	Qty
1	Seat	PTFE	2
2	Ball	SS316	1
3	Joint Gasket	PTFE	1
4	Cap	SS316	1
5	Body	SS316/CF8M	1
6	Stem	SS316	1
7	Thrust Washer	PTFE	1
8	Stem Packing	PTFE	1
9	Gland Nut	SS304	1
10	Stem Washer	SS304	1
11	Stem Nut	SS304	1
12	Handle Cover	PLASTIC	1
13	Handle	SS304	1

Manual Valves Dimensions & Specifications

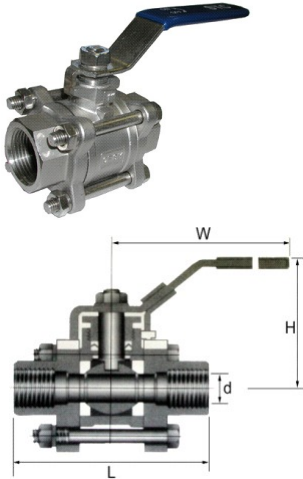

V3 Valve Specifications	
Maximum Operating Pressure:	1/2" to 2" 1000 PSI @ 100°F WOG* 2 1/2" to 3" 800 PSI @ 100°F WOG*
Temperature Range:	-60 to 450°F
Full Port	
End Connections:	FNPT
Mounting Options:	Padlocking Device and Actuator Mounting Bracket

Dimensions (mm)		SIZE										
		1/4"	3/8"	1/2"	3/4"	1"	1 1/4"	1 1/2"	2"	2 1/2"	3"	4"
d	mm	12.5	12.5	15	20	25	30	38	50	64	80	98
	in	0.49	0.49	0.59	0.79	0.98	1.18	1.5	1.97	2.52	3.15	3.86
H	mm	57	57	68	70	80	84	93	100	142	155	172
	in	2.24	2.24	2.68	2.76	3.15	3.31	3.66	3.94	5.59	6.1	6.77
W	mm	96	96	124	124	142	142	202	202	250	250	300
	in	3.78	3.78	4.88	4.88	5.99	5.99	7.95	7.95	9.84	9.84	11.81
L	mm	68	68	72	83	90	112	120	147	174	193	216
	in	2.56	2.56	2.84	3.35	3.62	4.33	4.48	5.59	6.85	7.6	8.5

Main Parts and Materials			
No	Part Name	Material	Qty
1	Seat	PTFE	2
2	Ball	SS316	1
3	Joint Gasket	PTFE	1
4	Cap	SS316	1
5	Body, Body Connector	SS316/CF8M	1, 2
6	Stem	SS316	1
7	Thrust Washer	PTFE	1
8	Stem Packing	PTFE	1
9	Gland Nut	SS304	1
10	Stem Washer	SS304	1
11	Stem Nut	SS304	1
12	Handle Cover	PLASTIC	1
13	Handle	SS304	1
14	Body Connector Bolt	SS304	4
15	Body Connector Nut & Washer	SS304	4

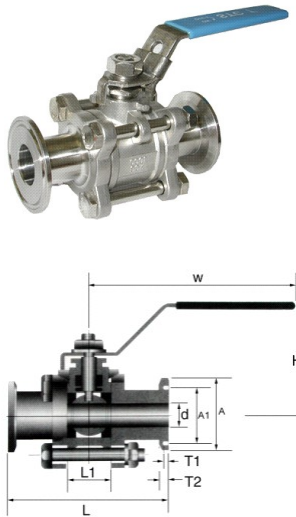

V3C Valve Specifications	
Sanitary Stainless Steel Ball Valve: These valves are made with precision machined Teflon seats for use in sanitary applications. They are three piece designs and have four bolts that permit quick and easy access to service the valve without disrupting the pipeline connections.	
Maximum Operating Pressure:	1/2" to 2" 1000 PSI @ 100°F WOG* 2 1/2" to 4" 800 PSI @ 100°F WOG*
Temperature Range:	-60 to 450°F
Full Port	
End Connections:	Clamp End
Mounting Options:	Padlocking device and actuator mounting bracket.

Dimensions (mm)		Size						
Port (d)	L	A	A1	H	T1	T2	W	
1/2"	9.6	75	25	20.24	64	--	3.63	125
3/4"	15.9	90	25	20.24	67	--	3.63	125
1"	22.2	100	50.4	43.6	83	2.85	4.75	140
1 1/4"	28.5	110	50.4	43.6	89	2.85	4.75	140
1 1/2"	34.9	125	50.4	43.6	100	2.85	--	200
2"	47.5	150	63.9	56.3	108	2.85	--	200
2 1/2"	60.2	190	77.4	70.6	150	2.85	--	250
3"	72.9	220	90	83.3	161	2.85	--	250
4"	97.4	270	118.9	110.3	180	2.85	--	250

Main Parts and Materials			
No	Part Name	Material	Qty
1	Seat	PTFE	2
2	Ball	SS316	1
3	Joint Gasket	PTFE	1
4	Cap	SS316	1
5	Body, Body Connector	SS316/CF8M	1, 2
6	Stem	SS316	1
7	Thrust Washer	PTFE	1
8	Stem Packing	PTFE	1
9	Gland Nut	SS304	1
10	Stem Washer	SS304	1
11	Stem Nut	SS304	1
12	Handle Cover	Plastic	1
13	Handle	SS304	1
14	Connector Bolt	SS304	4
15	Connector Nut & Washer	SS304	4

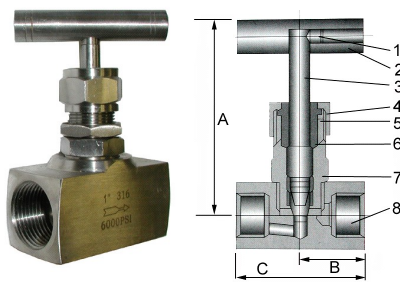

VN01 Valve Specifications	
End Connections:	NPT threaded ASME b1.20.1
	DIN 2999 & BS21; ISO 228/1 & ISO 7/1
Max. Operating Pressure:	6000 PSIG @ 100°F
Operating Temperature Range:	-60 to 450°F
	Panel Mount & Fire Safe Design
Non-Rotating, hardened needle design for leak-tight shutoff and long service life.	

Dimensions (mm)		Size				
		1/4"	3/8"	1/2"	3/4"	1"
A	75	75	87	90	103	
B	25	25	30	32.5	40	
C	50	50	60	65	80	
Cv	0.43	0.74	1.36	2.64	3.6	
Panel Hole	20	20		22	24	

Main Parts and Materials		
No	Part Name	Material
1	Set Screw	SS304
2	Handle	SS410
3	Stem	SS316
4	Gland Nut	SS304
5	Gland	SS304
6	Packing	TEFLON
7	Bonnet	SS316/CF8M
8	Body	SS316/CF8M

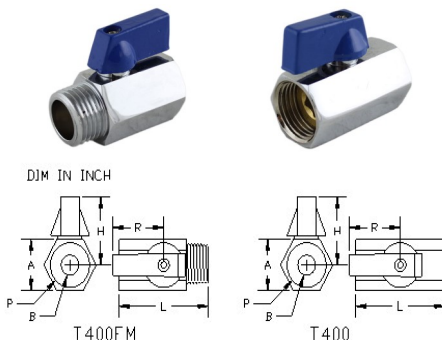

T400 & T400FM Valve Specifications		
Valve Type	T400	T400FM
Operating Pressure	0-450 PSI @ 75 °F	
Operating Temperature	0 TO 200 Deg. F	
Ball	Chrome Plated Brass	
Body Materials	Chrome or Nickel Plated Brass	
Seal Materials	PTFE	
Handle	Metal or Plastic	
Service	Air, Liquid	

	A	B (BORE)	H	L	P (NPT)	R
T400 1/4	0.80	0.31	1.00	1.58	1/4	0.93
T400 3/8	0.80	0.31	1.00	1.58	3/8	0.93
T400 1/2	0.96	0.39	1.10	1.78	1/2	0.93
T400FM 1/4	0.80	0.31	1.00	1.58	1/4	0.93
T400FM 3/8	0.80	0.31	1.00	1.58	3/8	0.93
T400FM 1/2	0.96	0.39	1.10	1.78	1/2	0.93



Precision Engineered

Fine Quality



Advanced Design

Excellent Prices



Contents

Air Actuated Ball Valve Numbering System.....	D2
Air Actuated Ball Valve List Price.....	D3
Air Actuated Ball Valve Specifications	D4
Rotary Air Actuator Dimensions & Specifications.....	D5
Electric Actuator List Price & Specifications	D6
Air Actuated Angle Seat Valve List Price & Specifications.....	D7
Actuated Angle Seat Valve Technical Data & Dimensions.....	D8

Ordering Part No. =
(e.g., KS 2-S-2-D-P)



Proximity Switch/Indicator



Electrical Connection



Namur Style Solenoid Valve



Model Name		Port Size (in)	Connection		Valve Type		Valve Material		Options	
Single Acting (Spring Return)	KS	1/4	NPT	(leave blank)	2 Way, Normally Closed	(leave blank)	316 Stainless Steel	(leave blank)	Namur Solenoid Valve	
Double Acting (Air Return)		3/8	Tri-Clamp	C	2 Way, Normally Open	O	Brass	B	Coil Voltage	12VDC
	1/2	Flange	F	3 Way (L Port)	L			24VDC		2
	3/4	BSPP	G	3 Way (T Port)	T			24VAC		2A
	1	BSPT	R					110VAC 50/60HZ		3
	1 1/4	Socket Weld	S					220VAC 50/60HZ		4
	1 1/2	Butt Weld	W							
	2							Coil Electrical	DIN	D
	2 1/2								2 Lead Wires	G
	3								1/2NPT for Conduit	N
	4								Explosion Proof Coil	E
	6							Proximity Switch, 2 SPDT (APL-210N)		P
								Proximity Switch, 2 SPDT, Exp. Proof (APL-410)		X

Rotary Pneumatic Ball Valve		Air Actuated Ball Valve List Price					Specifications
		Port Size NPT	Air Actuated Single Acting		Air Actuated Double Acting		
			Model No.	Price	Model No.	Price	
	2/2 3 Piece Full Port Ball Valve 316 SS	1/4"	KS 1/4	\$274.68	KD 1/4	\$238.16	Fluid Temperature with PTFE seal: -10°C to 180°C Pressure: Vacuum to 1000 PSI Service: Air, Gas, Liquid, Steam, Vacuum
		3/8"	KS 3/8	\$274.68	KD 3/8	\$238.16	
		1/2"	KS 1/2	\$274.68	KD 1/2	\$238.16	
		3/4"	KS 3/4	\$289.30	KD 3/4	\$245.45	
		1"	KS 1	\$333.11	KD 1	\$303.90	
		1 1/4"	KS 1 1/4	\$447.92	KD 1 1/4	\$347.74	
		1 1/2"	KS 1 1/2	\$581.51	KD 1 1/2	\$450.00	
		2"	KS 2	\$769.99	KD 2	\$537.68	
		2 1/2"	KS 2 1/2	\$1,225.76	KD 2 1/2	\$1,183.32	
		3"	KS 3	\$1,458.14	KD 3	\$1,312.03	
4"	KS 4	\$3,344.34	KD 4	\$3,097.29			

Model	Namur Solenoid Valves for Controlling Air Actuated Valves					
	Part No. = Model — Voltage Option — Electrical Options					
	Model	Voltage Options	Electrical Options	Non-Exp. Proof List Price	Exp. Proof List Price	
 Non-Exp. Proof	3 Way Namur Single Solenoid Valve	3V310-1/4B	1 = 12 VDC 2 = 24VDC 2A=24VAC 3 = 110VAC 4 = 220VAC (50/60Hz)	D = DIN G = Grommet (12" Lead Wire) E = Explosion Proof	\$54.99	\$248.78
	3 Way Namur Double Solenoid Valve	3V320-1/4B			\$81.16	\$367.04
 Exp. Proof	4 Way Namur Single Solenoid Valve	4V310-1/4B			\$54.99	\$248.78
	4 Way Namur Double Solenoid Valve	4V320-1/4B			\$81.16	\$367.04
	Flow Control for Namur Valve	ASC N1/4B			\$19.61	

Model	STC Proximity Switches/Position Indicators					
	Part No.	List Price	Voltage	Current	Cable Entry	Specifications
	APL-210N	\$102.72	Max. 250VAC or DC	5A @ 8 to 14VDC 4A @ 30VDC 0.4A @ 125VDC 0.2A @ 250VDC 5A @ 125VAC, 3A @ 250VAC	2-1/2 NPT	Position Indicator for Rotary Actuator, IP 67 ENCLOSURE, 2 SPDT Mechanical Limit Switches, Visual OPEN/CLOSED Indicator
	APL-310N	\$179.72	Max. 250VAC or DC	0.6A 125VDC, 0.3A 250V DC 16A 125 to 250VAC	2-1/2 NPT	Position Indicator for Rotary Actuator, 2 SPDT Mechanical Limit Switches, Visual OPEN/CLOSED Indicator
	APL-410	\$359.42	Max. 250VAC or DC	0.6A 125VDC, 0.3A 250VDC 15A 125 to 250 VAC	2-3/4 NPT	Explosion Proof Position Indicator for Rotary Actuator, Exd II BT6, IP 67 ENCLOSURE, 2 SPDT Mechanical Limit Switches, Visual OPEN/CLOSED Indicator

Air Actuated Ball Valve Size & Specifications

Actuated Valve Body Specifications	
Valve Body & Ball	316 Stainless Steel / CF8M
Seat Seals & Packing	PTFE
Service Medium	Air, Gas, Liquid, Steam, Water
Operating Pressure	1/4" to 2": 1000 PSI @ 100°F WOG 2 1/2" to 4": 800 PSI @ 100°F WOG
Media Temperature	-60 to 450 °F
Ambient Temperature	-4 to 176 °F (-20 TO 80 °C)
Maximum Viscosity	600 mm ² /s
Installation Orientation	Any Orientation
Controlling Medium	Air, Inert Gas
Controlling Pressure Range	45-120 PSI
Mounting standard	DIN 3203-M3, ISO 5211 MOUNTING PAD, ISO5211 PLATFORM
Port	2 Way: Full Port 3 Way: Reduced Port

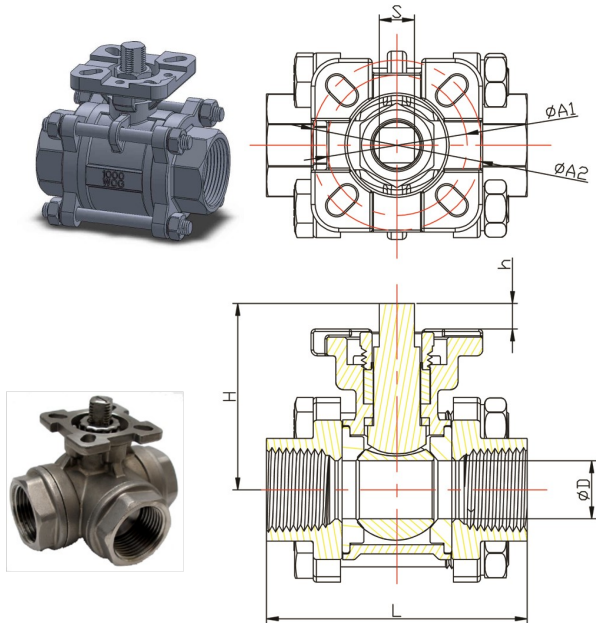

Actuated Valve Body Dimensions (mm)										
SIZE	2 WAY	3 WAY		D	L	H	h	S	Actuator Mounting: ISO05211	
		L Port Part No.	T Port Part No.						A1/(MM)	A2/(MM)
1/4"	V3-1/4-A	V3-1/4-L-A		8	75	47	8	9	36	42
3/8"	V3-3/8-A	V3-3/8-L-A	V3-3/8-T-A	10	75	47	8	9	36	42
1/2"	V3-1/2-A	V3-1/2-L-A	V3-1/2-T-A	15	75	38	9	9	F03/36	F04/42
3/4"	V3-3/4-A	V3-3/4-L-A	V3-3/4-T-A	20	80	47	9	9	F03/36	F04/42
1"	V3-1-A	V3-1-L-A	V3-1-T-A	25	90	57.2	11	11	F04/42	F05/50
1 1/4"	V3-1 1/4-A	V3-1 1/4-L-A	V3-1 1/4-T-A	32	110	62.5	11	11	F04/42	F05/50
1 1/2"	V3-1 1/2-A	V3-1 1/2-L-A	V3-1 1/2-T-A	38	120	77.5	14	14	F05/50	F07/70
2"	V3-2-A	V3-2-L-A	V3-2-T-A	50	140	86.5	14	14	F05/50	F07/70
2 1/2"	V3-2 1/2-A	V3-2 1/2-L-A	V3-2 1/2-T-A	65	162	108	17	17	F07/70	F10/102
3"	V3-3-A	V3-3-L-A	V3-3-T-A	80	184	115	17	17	F07/70	F10/102
4"	V3-4-A	V3-4-L-A	V3-4-T-A	100	228	141	22	22	F07/70	F10/102

Air Actuator Sizing Guide							
Size	2 WAY	Air Actuator Size		3 WAY		Air Actuator Size	
		Double Acting	Single Acting	L Port Part No.	T Port Part No.	Double Acting	Single Acting
1/4"	V3-1/4-A	AT32D	AT050S	V3-1/4-L-A		AT32D	AT050S
3/8"	V3-3/8-A	AT32D	AT050S	V3-3/8-L-A	V3-3/8-T-A	AT50D	AT050S
1/2"	V3-1/2-A	AT50D	AT063S	V3-1/2-L-A	V3-1/2-T-A	AT050D	AT063S
3/4"	V3-3/4-A	AT50D	AT063S	V3-3/4-L-A	V3-3/4-T-A	AT050D	AT063S
1"	V3-1-A	AT50D	AT063S	V3-1-L-A	V3-1-T-A	AT063D	AT075S
1 1/4"	V3-1 1/4-A	AT63D	AT075S	V3-1 1/4-L-A	V3-1 1/4-T-A	AT063D	AT075S
1 1/2"	V3-1 1/2-A	AT63D	AT088S	V3-1 1/2-L-A	V3-1 1/2-T-A	AT075D	AT088S
2"	V3-2-A	AT75D	AT088S	V3-2-L-A	V3-2-T-A	AT088D	AT100S
2 1/2"	V3-2 1/2-A	AT88D	AT100S	V3-2 1/2-L-A	V3-2 1/2-T-A	AT100D	AT125S
3"	V3-3-A	AT100D	AT125S	V3-3-L-A	V3-3-T-A	AT125D	AT145S
4"	V3-4-A	AT115D	AT145S	V3-4-L-A	V3-4-T-A	AT145D	AT160S

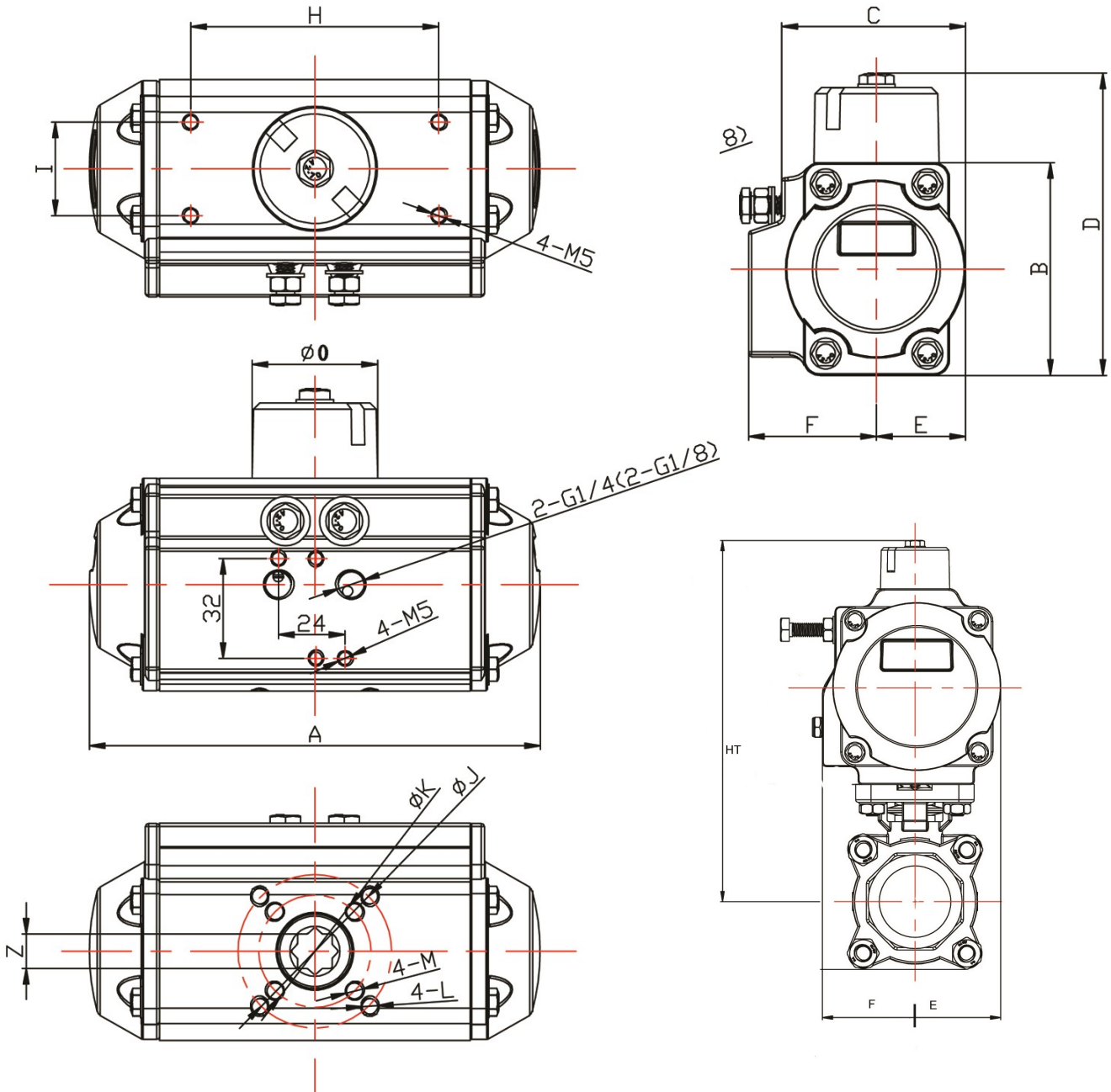

Rotary Air Actuator Dimensions																				
Model Double Acting	Model Single Acting	Size	A	B	C	D	E	F	G	H	I	J	K	L	M	N	O	A120	A180	Air Connection
AT032D	AT032S	32	110	45	45	65	22.5	23	12	50	25		F03/36		M5X5	9				G1/8
AT050D	AT050S	50-52	143	72	55	92	30	41	14	80	30	F05/50	F03/36	M6X8	M5X8	11	40	158	200	G1/4
AT063D	AT063S	63	190	88	69	108	35	45	18	90	30	F07/70	F05/50	M8X13	M6X10	14	40	184	233	G1/4
AT075D	AT075S	75	207	99.5	100.5	119.5	38.5	52.5	20.5	80	30	F07/70	F05/50	M8X10	M6X8	14	40	203	243	G1/4
AT088D	AT088S	85-88	213	109	88	129	46	52.5	21	80	30	F07/70	F05/50	M8X13	M6X10	17	40	221	280	G1/4
AT092D	AT092S	92	258	117	98.5	137	50	61	21	80	30	F07/70	F05/50	M8X12	M6X10	17	40	280	374	G1/4
AT0100D	AT0100S	100-105	267	133	109	153	57	64	26	80	30	F10/102	F07/70	M10X13	M8X10	22	40	304	388	G1/4
AT125D	AT125S	125	340	155	120.5	175	67.5	70	27.5	80	30	F10/102	F07/70	M10X16	M8X13	22	65	365	470	G1/4
AT145D	AT145S	140-145	414	171.5	132	191.5	75	76	32	80	30	F12/125	F10/102	M12X20	M10X15	27	65	442	568	G1/4

NOTE: A120 and A180 represent the acting length of the 120° rotation travel and 180° rotation travel, respectively.

Electric Actuator List Price & Specifications

Ordering Part No. =
(e.g., E 1/2-3-S)



Indicator / Control



Model Name		Port Size (in)	Connection		Valve Type		Valve Material		Options		
Electric Actuated Valves	E	1/4	NPT	(leave blank)	2 Way, Normally Closed	(leave blank)	316 Stainless Steel	(leave blank)	Coil Voltage	24VDC	2
		1/2	Tri-Clamp	C	2 Way, Normally Open	O				24VAC	2A
		3/4	Flange	F						110VAC 50/60HZ	3
		1	BSPP	G						220VAC 50/60HZ	4
		1 1/4	BSPT	R					3 Way (L Port)	L	Control Signal
		1 1/2	Socket Weld	S	Contact Signal	S					
		2	Butt Weld	W	1K, 5K Potentiometer	R					
		2 1/2			4-20 mA (for Proportional Control)	PC					
3											
4											

Valve Body	2 Way Valve with Actuator with ON/OFF Indicator		2 Way Valve with Actuator with Contact Signal		2 Way Valve with Actuator with Proportional Control		3 Way (L Ball) with Actuator with ON/OFF Indicator		3 Way (T Ball) with Actuator with ON/OFF Indicator	
Port Size (NPT)	Part No.	Price	Part No.	Price	Part No.	Price	Part No.	Price	Part No.	Price
1/4	E 1/4-V	\$668.33	E 1/4-V-S	\$727.96	E 1/4-V-T	\$1,383.40	E 1/4-L-V	\$686.77	E 1/4-T-V	\$686.77
3/8	E 3/8-V	\$668.33	E 3/8-V-S	\$727.96	E 3/8-V-T	\$1,383.40	E 3/8-L-V	\$686.77	E 3/8-T-V	\$686.77
1/2	E 1/2-V	\$668.33	E 1/2-V-S	\$727.96	E 1/2-V-T	\$1,383.40	E 1/2-L-V	\$686.77	E 1/2-T-V	\$686.77
3/4	E 3/4-V	\$681.83	E 3/4-V-S	\$741.46	E 3/4-V-T	\$1,396.91	E 3/4-L-V	\$712.50	E 3/4-T-V	\$712.50
1	E 1-V	\$718.70	E 1-V-S	\$778.33	E 1-V-T	\$1,433.79	E 1-L-V	\$759.89	E 1-T-V	\$759.89
1 1/4	E 1 1/4-V	\$761.14	E 1 1/4-V-S	\$820.76	E 1 1/4-V-T	\$1,476.21	E 1 1/4-L-V	\$867.73	E 1 1/4-T-V	\$867.73
1 1/2	E 1 1/2-V	\$873.64	E 1 1/2-V-S	\$933.28	E 1 1/2-V-T	\$1,588.73	E 1 1/2-L-V	\$1,049.67	E 1 1/2-T-V	\$1,049.67
2	E 2-V	\$1,171.98	E 2-V-S	\$1,231.60	E 2-V-T	\$1,887.05	E 2-L-V	\$1,368.38	E 2-T-V	\$1,368.38
2 1/2	E 2 1/2-V	\$1,475.53	E 2 1/2-V-S	\$1,535.15	E 2 1/2-V-T	\$2,190.62				
3	E 3-V	\$2,145.89	E 3-V-S	\$2,205.42	E 3-V-T	\$2,860.94				
4	E 4-V	\$2,865.96	E 4-V-S	\$2,925.59	E 4-V-T	\$3,581.04				

Electric Actuator	Part No.	List Price	Torque (N*m)	Cycle Time (sec)	Motor Power (W)	Special function	Control Signal	2 Way Ball Valve Size, NPT	3 Way Ball Valve Size, NPT	Voltage Options	Rotation
	E-02	\$496.54	6	7	4.6	On-off Light	Light Indicator	N/A	1/4"	24VDC, 24VAC, 110VAC, 220VAC	90°
	E-05	\$595.88	50	20	10 (DC); 15 (AC)			1/4" to 1 1/2"	1/2" to 1 1/4"		
	E-10	\$834.27	100	30/60	20 (DC); 25 (AC)			2" to 2 1/2"	1 1/2" to 2"		
	E-20	\$1,132.25	200	30/60	40			3" to 4"	2 1/2"		
	E-40	\$1,191.81	400	30/60	90			N/A	3"		
	E-60	\$1,489.79	600	45	90	Passive Contact	S = Contact Signal	N/A	4"	24VDC, 24VAC, 110VAC, 220VAC	90°
	E-05S	\$655.54	50	20	10 (DC); 15 (AC)			1/4" to 1 1/2"	1/2" to 1 1/4"		
	E-10S	\$893.88	100	30/60	20 (DC); 25 (AC)			2" to 2 1/2"	1 1/2" to 2"		
	E-20S	\$1,191.81	200	30/60	40			3" to 4"	2 1/2"		
	E-40S	\$1,251.43	400	30/60	90	Opening Signal	R = Potentiometer (1-5K)	N/A	3"	24VDC, 24VAC, 110VAC, 220VAC	90°
	E-05R	\$774.71	50	20	10 (DC); 15 (AC)			1/4" to 1 1/2"	1/2" to 1 1/4"		
	E-10R	\$1,013.05	100	30/60	20 (DC); 25 (AC)			2" to 2 1/2"	1 1/2" to 2"		
	E-20R	\$1,310.99	200	30/60	40			3" to 4"	2 1/2"		
	E-40R	\$1,370.61	400	30/60	90	Proportional Control	T = 4-20mA	N/A	3"	24VDC, 24VAC, 110VAC, 220VAC	90°
	E-05PC	\$1,310.99	50	20	10 (DC); 15 (AC)			1/4" to 1 1/2"	1/2" to 1 1/4"		
	E-10PC	\$1,549.34	100	30/60	20 (DC); 25 (AC)			2" to 2 1/2"	1 1/2" to 2"		
	E-20PC	\$1,847.33	200	30/60	40			3" to 4"	2 1/2"		
E-40PC	\$1,906.87	400	30/60	90			N/A	3"			

Ordering Part No. =
(e.g., 2KD-3/4)



Air Actuated Valve	
Single Acting (Spring Return)	2KS
Double Acting (Fail Closed)	2KD

Port Size (NPT)
3/8"
1/2"
3/4"
1"
1 1/4"
1 1/2"
2"

Options	
NPT	(leave blank)
Tri-Clamp	C
Flange	F
BSPT	R
Butt Weld	W

Model	Port Size NPT	316 Stainless Steel Air Actuated Angle Seat Valve List Price			
		Single Acting (Normally Closed)		Double Acting (Fail Closed)	
		Model	Price	Model	Price
	3/8	2KS-3/8	\$224.94	2KD-3/8	\$224.94
	1/2	2KS-1/2	\$243.71	2KD-1/2	\$243.71
	3/4	2KS-3/4	\$249.92	2KD-3/4	\$249.92
	1	2KS-1	\$307.41	2KD-1	\$307.41
	1 1/4	2KS-1 1/4	\$437.37	2KD-1 1/4	\$437.37
	1 1/2	2KS-1 1/2	\$462.28	2KD-1 1/2	\$462.28
	2	2KS-2	\$637.30	2KD-2	\$637.30
	2 1/2	2KS-2 1/2	\$769.99	2KD-2 1/2	\$769.99
	3	2KS-3	\$1,896.59	2KD-3	\$1,896.59

2KS & 2KD Specifications & Features	
Operating Pressure	29" Hg Vacuum to 240 PSI (0-1.6MPa)
Temperature Range	-5 to 356°F (-20 to 180°C)
Ambient Temperature	-5 to 40°F (-20 to 60°C)
Maximum Viscosity	600 mm ² /s (600 centistokes)
Installation Orientation	Any orientation
Pilot Controlling Medium	Air, Inert Gas
Pilot Pressure Range	65-120 PSI
Wetted Surfaces	300 Series Stainless Steel and PTFE
Service Medium	Air, Gas, Liquid, Oil, Steam, Water, Vacuum

Materials of Construction	
Valve Body	316 Stainless Steel
Valve Stem	316 Stainless Steel
Seat Seals	PTFE
Stem Seals	PTFE (Spring loaded self-adjusting for long service life)
Actuator Body	Stainless Steel CF8 (Designed for harsh applications)
Piston	HPb59-1
Piston Ring V-Seals	NBR / FKM (Viton)
Spring	Stainless Steel
Indicative Stem	HPb59-1
Top Cap	Polycarbonate

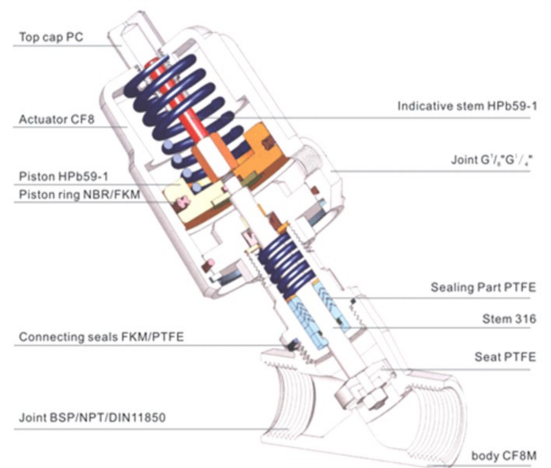

Actuated Angle Seat Valve Technical Data & Dimensions

2KS Series Single Acting Stainless Steel Air Actuated Angle Seat Valve Specifications

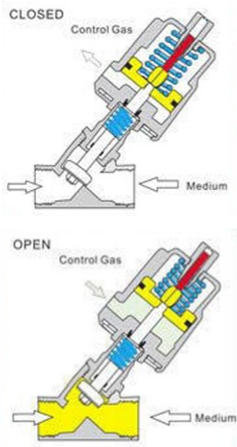

Part No.	Port (NPT)	Standard	Orifice (mm)	Actuator (mm)	Cv	Bi-directional Flow		Temperature	Pilot Control Pressure
						Inlet Above Seat Pressure @ 180 °C	Inlet Below Seat Pressure @ 180 °C		
2KS-3/8	3/8"	DN10	13	50	4.7	0-240 PSI (0-1.6MPa)	0-240 PSI (0-1.6MPa)	-5 to 356°F (-20 to 180°C)	65-120 PSI
2KS-1/2	1/2"	DN15	13	50	4.7	0-240 PSI (0-1.6MPa)	0-240 PSI (0-1.6MPa)	-5 to 356°F (-20 to 180°C)	65-120 PSI
2KS-3/4	3/4"	DN20	18	50	9.5	0-240 PSI (0-1.6MPa)	0-180 PSI (0-1.2MPa)	-5 to 356°F (-20 to 180°C)	65-120 PSI
2KS-1	1"	DN25	24	63	18.1	0-240 PSI (0-1.6MPa)	0-150 PSI (0-1.0MPa)	-5 to 356°F (-20 to 180°C)	65-120 PSI
2KS-1 1/4	1 1/4"	DN32	31	63	23.1	0-240 PSI (0-1.6MPa)	0-90 PSI (0-0.6MPa)	-5 to 356°F (-20 to 180°C)	65-120 PSI
2KS-1 1/2	1 1/2"	DN40	35	80	32.9	0-240 PSI (0-1.6MPa)	0-150 PSI (0-1.0MPa)	-5 to 356°F (-20 to 180°C)	65-120 PSI
2KS-2	2"	DN50	45	80	52.8	0-240 PSI (0-1.6MPa)	0-90 PSI (0-0.6MPa)	-5 to 356°F (-20 to 180°C)	65-120 PSI
2KS-2 1/2	2 1/2"	DN65	65	125	76	0-240 PSI (0-1.6MPa)	0-90 PSI (0-0.6MPa)	-5 to 356°F (-20 to 180°C)	65-120 PSI

2KD Series Double Acting Stainless Steel Air Actuated Angle Seat Valve Specifications

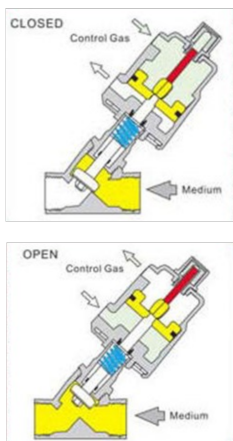

Part No.	Port (NPT)	Standard	Orifice (mm)	Actuator Diameter (mm)	Cv	Bi-directional Flow		Media Temperature	Pilot Control Pressure
						Inlet Above Seat Pressure @ 180 °C	Inlet Below Seat Pressure @ 180 °C		
2KD-3/8	3/8"	DN10	13	50	4.7	0-240 PSI (0-1.6MPa)	0-240 PSI (0-1.6MPa)	-5 to 356°F (-20 to 180°C)	65-120 PSI
2KD-1/2	1/2"	DN15	13	50	4.7	0-240 PSI (0-1.6MPa)	0-240 PSI (0-1.6MPa)	-5 to 356°F (-20 to 180°C)	65-120 PSI
2KD-3/4	3/4"	DN20	18	50	9.5	0-240 PSI (0-1.6MPa)	0-240 PSI (0-1.6MPa)	-5 to 356°F (-20 to 180°C)	65-120 PSI
2KDS-1	1"	DN25	24	63	18.1	0-240 PSI (0-1.6MPa)	0-240 PSI (0-1.6MPa)	-5 to 356°F (-20 to 180°C)	65-120 PSI
2KD-1 1/4	1 1/4"	DN32	31	63	23.1	0-240 PSI (0-1.6MPa)	0-240 PSI (0-1.6MPa)	-5 to 356°F (-20 to 180°C)	65-120 PSI
2KD-1 1/2	1 1/2"	DN40	35	80	32.9	0-240 PSI (0-1.6MPa)	0-240 PSI (0-1.6MPa)	-5 to 356°F (-20 to 180°C)	65-120 PSI
2KD-2	2"	DN50	45	80	52.8	0-240 PSI (0-1.6MPa)	0-240 PSI (0-1.6MPa)	-5 to 356°F (-20 to 180°C)	65-120 PSI
2KD-2 1/2	2 1/2"	DN65	65	125	76	0-240 PSI (0-1.6MPa)	0-240 PSI (0-1.6MPa)	-5 to 356°F (-20 to 180°C)	65-120 PSI

2KS/KD Series Stainless Steel Air Actuated Angle Plunger Valve Dimensions

★ Overall Dimension

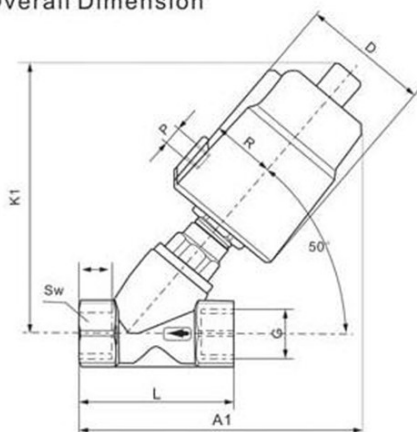

Single Acting Part No.	Double Acting Part No.	Port (NPT)	A	R	P	K1	A1	L	T	SW
2KS-3/8	2KD-3/8	3/8"	60	35	1/8	126	133	68	12	26.6
2KS-1/2	2KD-1/2	1/2"	60	35	1/8	126	133	68	15	26.6
2KS-3/4	2KD-3/4	3/4"	60	35	1/8	131	137	75	16	32
2KS-1	2KD-1	1"	77	43	1/8	165	174	90	17	39.5
2KS-1 1/4	2KD-1 1/4	1 1/4"	77	43	1/8	175	188	116	21	50
2KS-1 1/2	2KD-1 1/2	1 1/2"	98	52	1/4	187	204	116	21	55.3
2KS-2	2KD-2	2"	98	52	1/4	195	218	138	22	70

Units in mm



Precision Engineered

Fine Quality



Advanced Design



Excellent Prices

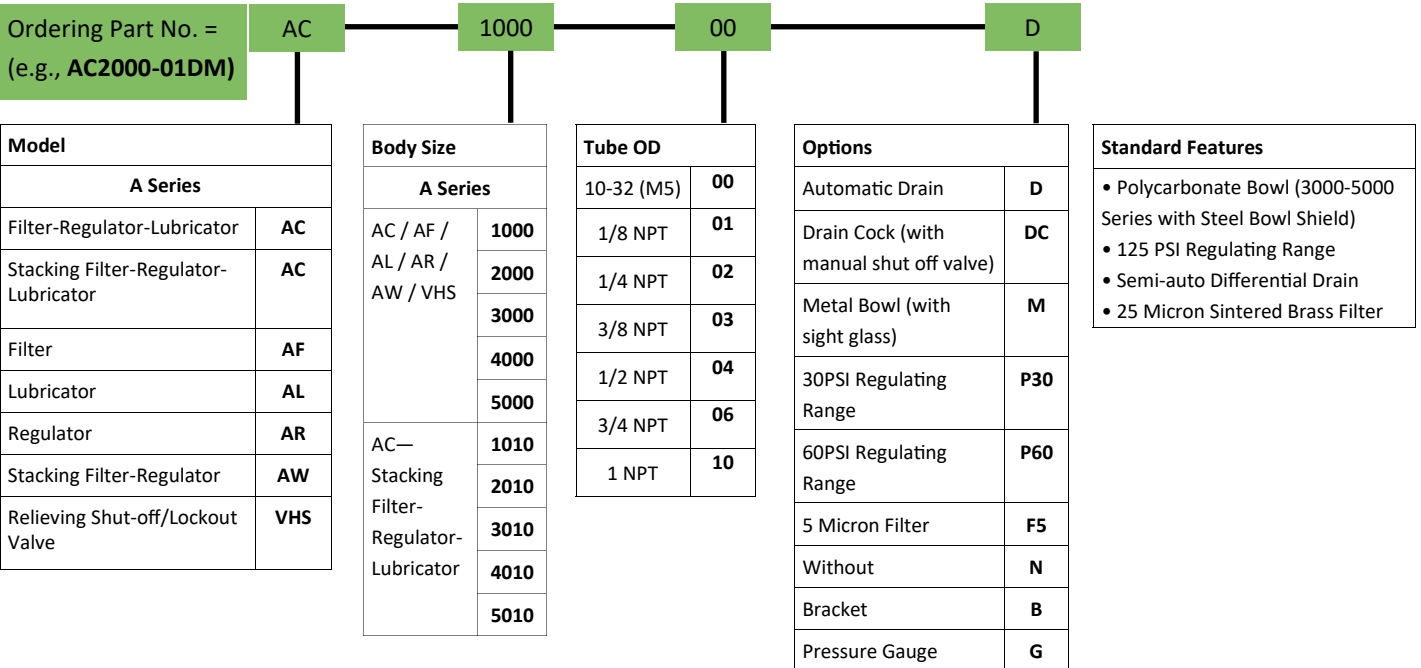

Contents

Filter Regulator Lubricator Numbering System.....	E2
Air Filter-Regulator-Lubricator List Price.....	E3
Air Filter & Regulator List Price.....	E4
Air Lubricator & Filter-Regulator List Price.....	E5
FRL Mounting Hardware List Price.....	E6
Air FRL Specifications.....	E7
Air Filter-Regulator-Lubricator Flow Charts.....	E8 - E12
Air Filter-Regulator-Lubricator Dimensions.....	E13 - E15







	Part No.	Description (*Includes Bracket & Gauge)	List Price
 <p>*Includes Bracket & Gauge</p>	AC1000-M5	M5/10-32 Filter- Regulator- Lubricator* (3 SCFM)	\$68.42
	AC2000-01	1/8" NPT Filter- Regulator- Lubricator* (18 SCFM)	\$71.82
	AC2000-01D	1/8" NPT Filter- Regulator- Lubricator* with Auto Drain (18 SCFM)	\$96.40
	AC2000-01M	1/8" NPT Filter- Regulator- Lubricator* Metal Bowl (18 SCFM)	\$86.74
	AC2000-01DM	1/8" NPT Filter- Regulator- Lubricator* with Auto Drain & Metal Bowl (18 SCFM)	\$106.42
	AC2000-02	1/4" NPT Filter- Regulator- Lubricator* (18 SCFM)	\$71.82
	AC2000-02D	1/4" NPT Filter- Regulator- Lubricator* with Auto Drain (18 SCFM)	\$96.40
	AC2000-02M	1/4" NPT Filter- Regulator- Lubricator* Metal Bowl (18 SCFM)	\$84.69
	AC2000-02DM	1/4" NPT Filter- Regulator- Lubricator* with Auto Drain & Metal Bowl (18 SCFM)	\$109.21
 <p>*Includes Bracket & Gauge</p>	AC3000-02	1/4" NPT Filter- Regulator- Lubricator* (70 SCFM)	\$110.46
	AC3000-02D	1/4" NPT Filter- Regulator- Lubricator* with Auto Drain (70 SCFM)	\$142.59
	AC3000-02M	1/4" NPT Filter- Regulator- Lubricator* with Metal Bowl (70 SCFM)	\$129.74
	AC3000-02DM	1/4" NPT Filter- Regulator- Lubricator* with Auto Drain & Metal Bowl (70 SCFM)	\$161.87
	AC3000-03	3/8" NPT Filter- Regulator- Lubricator* (70 SCFM)	\$110.46
	AC3000-03D	3/8" NPT Filter- Regulator- Lubricator* with Auto Drain (70 SCFM)	\$142.59
	AC3000-03M	3/8" NPT Filter- Regulator- Lubricator* with Metal Bowl (70 SCFM)	\$129.74
	AC3000-03DM	3/8" NPT Filter- Regulator- Lubricator* with Auto Drain & Metal Bowl (70 SCFM)	\$161.86
	AC4000-03	3/8" NPT Filter- Regulator- Lubricator* (140 SCFM)	\$148.98
	AC4000-03D	3/8" NPT Filter- Regulator- Lubricator* with Auto Drain (140 SCFM)	\$189.05
	AC4000-03M	3/8" NPT Filter- Regulator- Lubricator* with Metal Bowl (140 SCFM)	\$187.57
	AC4000-03DM	3/8" NPT Filter- Regulator- Lubricator* with Auto Drain & Metal Bowl (140 SCFM)	\$210.07
	AC4000-04	1/2" NPT Filter- Regulator- Lubricator* (140 SCFM)	\$148.98
	AC4000-04D	1/2" NPT Filter- Regulator- Lubricator* with Auto Drain (140 SCFM)	\$189.05
	AC4000-04M	1/2" NPT Filter- Regulator- Lubricator* with Metal Bowl (140 SCFM)	\$187.57
	AC4000-04DC	1/2" NPT Filter- Regulator- Lubricator* with Drain Cock (manual shut off valve) (140 SCFM)	\$148.98
	AC4000-04DM	1/2" NPT Filter- Regulator- Lubricator* with Auto Drain & Metal Bowl (140 SCFM)	\$210.07
AC4000-06	3/4" NPT Filter- Regulator- Lubricator* (160 SCFM)	\$162.97	
AC4000-06D	3/4" NPT Filter- Regulator- Lubricator* with Auto Drain (160 SCFM)	\$203.01	
AC4000-06M	3/4" NPT Filter- Regulator- Lubricator* with Metal Bowl (160 SCFM)	\$201.52	
AC4000-06DM	3/4" NPT Filter- Regulator- Lubricator* with Auto Drain & Metal Bowl (160 SCFM)	\$224.02	
AC5000-10	1" NPT Filter- Regulator- Lubricator* (180 SCFM)	\$205.39	
AC5000-10D	1" NPT Filter- Regulator- Lubricator* with Auto Drain (180 SCFM)	\$258.43	
AC5000-10M	1" NPT Filter- Regulator- Lubricator* with Metal Bowl (180 SCFM)	\$252.64	
AC5000-10DM	1" NPT Filter- Regulator- Lubricator* with Auto Drain & Metal Bowl (180 SCFM)	\$300.72	
 <p>*Includes Bracket & Gauge</p>	AC1010-M5	M5/10-32 Stacking Filter- Regulator- Lubricator* (3 SCFM)	\$61.18
	AC2010-01	1/8" NPT Stacking Filter- Regulator- Lubricator* (18 SCFM)	\$65.11
	AC2010-01D	1/8" NPT Stacking Filter- Regulator- Lubricator* with Auto Drain (18 SCFM)	\$89.74
	AC2010-01M	1/8" NPT Stacking Filter- Regulator- Lubricator* with Metal Bowl (18 SCFM)	\$80.23
	AC2010-01DM	1/8" NPT Stacking Filter- Regulator- Lubricator* with Auto Drain & Metal Bowl (18 SCFM)	\$99.37
	AC2010-02	1/4" NPT Stacking Filter- Regulator- Lubricator* (18 SCFM)	\$65.11
	AC2010-02D	1/4" NPT Stacking Filter- Regulator- Lubricator* with Auto Drain (18 SCFM)	\$89.74
	AC2010-02M	1/4" NPT Stacking Filter- Regulator- Lubricator* with Metal Bowl (18 SCFM)	\$80.23
	AC2010-02DM	1/4" NPT Stacking Filter- Regulator- Lubricator* with Auto Drain & Metal Bowl (18 SCFM)	\$99.37
 <p>*Includes Bracket & Gauge</p>	AC3010-02	1/4" NPT Stacking Filter- Regulator- Lubricator* (60 SCFM)	\$91.11
	AC3010-02D	1/4" NPT Stacking Filter- Regulator- Lubricator* with Auto Drain (60 SCFM)	\$123.27
	AC3010-02M	1/4" NPT Stacking Filter- Regulator- Lubricator* with Metal Bowl (60 SCFM)	\$105.03
	AC3010-02DM	1/4" NPT Stacking Filter- Regulator- Lubricator* with Auto Drain & Metal Bowl (60 SCFM)	\$132.59
	AC3010-03	3/8" NPT Stacking Filter- Regulator- Lubricator* (60 SCFM)	\$91.11
	AC3010-03D	3/8" NPT Stacking Filter- Regulator- Lubricator* with Auto Drain (60 SCFM)	\$123.27
	AC3010-03M	3/8" NPT Stacking Filter- Regulator- Lubricator* with Metal Bowl (60 SCFM)	\$110.41
	AC3010-03DM	3/8" NPT Stacking Filter- Regulator- Lubricator* with Auto Drain & Metal Bowl (60 SCFM)	\$133.05
	AC4010-03	3/8" NPT Stacking Filter- Regulator- Lubricator* (105 SCFM)	\$131.62
	AC4010-03D	3/8" NPT Stacking Filter- Regulator- Lubricator* with Auto Drain (105 SCFM)	\$171.70
	AC4010-03M	3/8" NPT Stacking Filter- Regulator- Lubricator* with Metal Bowl (105 SCFM)	\$170.20
	AC4010-04	1/2" NPT Stacking Filter- Regulator- Lubricator* (105 SCFM)	\$131.62
	AC4010-04D	1/2" NPT Stacking Filter- Regulator- Lubricator* with Auto Drain (105 SCFM)	\$171.70
	AC4010-04M	1/2" NPT Stacking Filter- Regulator- Lubricator* with Metal Bowl (105 SCFM)	\$170.20
	AC4010-04DM	1/2" NPT Stacking Filter- Regulator- Lubricator* with Auto Drain & Metal Bowl (105 SCFM)	\$192.73
	AC4010-06	3/4" NPT Stacking Filter- Regulator- Lubricator* (105 SCFM)	\$150.44
	AC4010-06D	3/4" NPT Stacking Filter- Regulator- Lubricator* with Auto Drain (105 SCFM)	\$190.50
AC4010-06M	3/4" NPT Stacking Filter- Regulator- Lubricator* with Metal Bowl (105 SCFM)	\$182.26	
AC4010-06DM	3/4" NPT Stacking Filter- Regulator- Lubricator* with Auto Drain & Metal Bowl (105 SCFM)	\$190.82	
AC5010-10	1" NPT Stacking Filter- Regulator- Lubricator* (140 SCFM)	\$188.05	
AC5010-10D	1" NPT Stacking Filter- Regulator- Lubricator* with Auto Drain (140 SCFM)	\$228.10	
AC5010-10DM	1" NPT Stacking Filter- Regulator- Lubricator* with Auto Drain & Metal Bowl (140 SCFM)	\$300.72	

Air Filter & Regulator List Price

	Part No.	Description (*Includes Bracket & Gauge)	List Price
	AF1000-M5	M5 Filter (4 SCFM)	\$17.34
	AF2000-01	1/8" NPT Filter (26 SCFM)	\$17.89
	AF2000-01D	1/8" NPT Filter with Auto Drain (26 SCFM)	\$42.52
	AF2000-01M	1/8" NPT Filter with Metal Bowl (26 SCFM)	\$26.60
	AF2000-01DM	1/8" NPT Filter with Auto Drain & Metal Bowl (26 SCFM)	\$44.83
	AF2000-02	1/4" NPT Filter (26 SCFM)	\$17.89
	AF2000-02D	1/4" NPT Filter with Auto Drain (26 SCFM)	\$42.52
	AF2000-02M	1/4" NPT Filter with Metal Bowl (26 SCFM)	\$26.60
	AF2000-02DM	1/4" NPT Filter Auto Drain & Metal Bowl (26 SCFM)	\$46.78
	AF3000-02	1/4" NPT Filter (70 SCFM)	\$26.99
	AF3000-02D	1/4" NPT Filter with Auto Drain (70 SCFM)	\$59.15
	AF3000-02M	1/4" NPT Filter with Metal Bowl (70 SCFM)	\$36.63
	AF3000-02DM	1/4" NPT Filter Auto Drain & Metal Bowl (70 SCFM)	\$64.27
	AF3000-03	3/8" NPT Filter (70 SCFM)	\$26.99
	AF3000-03D	3/8" NPT Filter with Auto Drain (70 SCFM)	\$59.15
	AF3000-03M	3/8" NPT Filter with Metal Bowl (70 SCFM)	\$36.63
	AF3000-03DM	3/8" NPT Filter Auto Drain & Metal Bowl (70 SCFM)	\$62.53
	AF4000-03	3/8" NPT Filter (140 SCFM)	\$37.61
	AF4000-03D	3/8" NPT Filter with Auto Drain (140 SCFM)	\$69.76
	AF4000-03M	3/8" NPT Filter with Metal Bowl (140 SCFM)	\$47.25
	AF4000-03DM	3/8" NPT Filter Auto Drain & Metal Bowl (140 SCFM)	\$79.40
	AF4000-04	1/2" NPT Filter (140 SCFM)	\$37.61
	AF4000-04D	1/2" NPT Filter with Auto Drain (140 SCFM)	\$69.76
	AF4000-04M	1/2" NPT Filter with Metal Bowl (140 SCFM)	\$47.25
	AF4000-04DM	1/2" NPT Filter Auto Drain & Metal Bowl (140 SCFM)	\$79.40
	AF4000-06	3/4" NPT Filter (210 SCFM)	\$41.95
	AF4000-06D	3/4" NPT Filter with Auto Drain (210 SCFM)	\$82.03
	AF4000-06M	3/4" NPT Filter with Metal Bowl (210 SCFM)	\$51.58
	AF4000-06DM	3/4" NPT Filter Auto Drain & Metal Bowl (210 SCFM)	\$86.39
	AF5000-10	1" NPT Filter (245 SCFM)	\$55.91
AF5000-10D	1" NPT Filter with Auto Drain (245 SCFM)	\$96.04	
AF5000-10M	1" NPT Filter with Metal Bowl (245 SCFM)	\$65.57	
AF5000-10DM	1" NPT Filter with Auto Drain & Metal Bowl (245 SCFM)	\$97.69	
	AR1000-M5	M5/10-32 Regulator* (4 SCFM)	\$28.88
	AR2000-01	1/8" NPT Regulator* (19 SCFM)	\$29.87
	AR2000-02	1/4" NPT Regulator* (19 SCFM)	\$29.87
	AR2500-02	1/4" NPT Regulator* (50 SCFM)	\$42.66
	AR3000-02	1/4" NPT Regulator* (88 SCFM)	\$46.28
	AR3000-03	3/8" NPT Regulator* (88 SCFM)	\$46.28
	AR4000-03	3/8" NPT Regulator* (210 SCFM)	\$61.70
	AR4000-04	1/2" NPT Regulator* (210 SCFM)	\$61.70
	AR4000-06	3/4" NPT Regulator* (210 SCFM)	\$71.34
	AR5000-06	3/4" NPT Regulator* (280 SCFM)	\$77.18
AR5000-10	1" NPT Regulator* (280 SCFM)	\$77.18	

*Includes Bracket & Gauge

	Part No.	Description (*Includes Bracket & Gauge)	List Price
	AL1000-M5	M5 Lubricator (3 SCFM)	\$17.34
	AL2000-01	1/8" NPT Lubricator (28 SCFM)	\$17.89
	AL2000-01M	1/8" NPT Lubricator with Metal Bowl (28 SCFM)	\$26.17
	AL2000-02	1/4" NPT Lubricator (28 SCFM)	\$17.89
	AL2000-02M	1/4" NPT Lubricator with Metal Bowl (28 SCFM)	\$26.17
	AL3000-02	1/4" NPT Lubricator (60 SCFM)	\$26.99
	AL3000-02M	1/4" NPT Lubricator with Metal Bowl (60 SCFM)	\$36.63
	AL3000-03	3/8" NPT Lubricator (60 SCFM)	\$26.99
	AL3000-03M	3/8" NPT Lubricator with Metal Bowl (60 SCFM)	\$36.63
	AL4000-03	3/8" NPT Lubricator (180 SCFM)	\$37.61
	AL4000-03M	3/8" NPT Lubricator with Metal Bowl (180 SCFM)	\$56.89
	AL4000-04	1/2" NPT Lubricator (180 SCFM)	\$37.61
	AL4000-04M	1/2" NPT Lubricator with Metal Bowl (180 SCFM)	\$56.89
	AL4000-06	3/4" NPT Lubricator (220 SCFM)	\$41.95
	AL4000-06M	3/4" NPT Lubricator with Metal Bowl (220 SCFM)	\$63.45
	AL5000-10	1" NPT Lubricator (245 SCFM)	\$59.31
	AL5000-10M	1" NPT Lubricator with Metal Bowl (245 SCFM)	\$78.59
	 <p>*Includes Bracket & Gauge</p>	AW1000-M5	M5 Filter- Regulator* (3 SCFM)
AW2000-01		1/8" NPT Filter- Regulator* (19 SCFM)	\$42.91
AW2000-01D		1/8" NPT Filter- Regulator* with Auto Drain (19 SCFM)	\$65.40
AW2000-01M		1/8" NPT Filter- Regulator* with Metal Bowl (19 SCFM)	\$50.02
AW2000-01DM		1/8" NPT Filter- Regulator* Auto Drain & Metal Bowl (19 SCFM)	\$71.82
AW2000-02		1/4" NPT Filter- Regulator* (19 SCFM)	\$42.91
AW2000-02D		1/4" NPT Filter- Regulator* with Auto Drain (19 SCFM)	\$65.40
AW2000-02M		1/4" NPT Filter- Regulator* with Metal Bowl (19 SCFM)	\$50.02
AW2000-02DM		1/4" NPT Filter- Regulator* Auto Drain & Metal Bowl (19 SCFM)	\$71.82
 <p>*Includes Bracket & Gauge</p>	AW3000-02	1/4" NPT Filter- Regulator* (70 SCFM)	\$57.85
	AW3000-02D	1/4" NPT Filter- Regulator* with Auto Drain (70 SCFM)	\$90.01
	AW3000-02M	1/4" NPT Filter- Regulator* with Metal Bowl (70 SCFM)	\$67.50
	AW3000-02DM	1/4" NPT Filter- Regulator* Auto Drain & Metal Bowl (70 SCFM)	\$99.65
	AW3000-03	3/8" NPT Filter- Regulator* (70 SCFM)	\$57.85
	AW3000-03D	3/8" NPT Filter- Regulator* with Auto Drain (70 SCFM)	\$90.01
	AW3000-03M	3/8" NPT Filter- Regulator* with Metal Bowl (70 SCFM)	\$67.50
	AW3000-03DM	3/8" NPT Filter- Regulator* Auto Drain & Metal Bowl (70 SCFM)	\$99.65
	AW4000-03	3/8" NPT Filter- Regulator* (140 SCFM)	\$86.79
	AW4000-03D	3/8" NPT Filter- Regulator* with Auto Drain (140 SCFM)	\$126.85
	AW4000-03M	3/8" NPT Filter- Regulator* with Metal Bowl (140 SCFM)	\$106.07
	AW4000-03DM	3/8" NPT Filter- Regulator* Auto Drain & Metal Bowl (140 SCFM)	\$146.11
	AW4000-04	1/2" NPT Filter- Regulator* (140 SCFM)	\$86.79
	AW4000-04D	1/2" NPT Filter- Regulator* with Auto Drain (140 SCFM)	\$126.85
	AW4000-04M	1/2" NPT Filter- Regulator* with Metal Bowl (140 SCFM)	\$106.07
	AW4000-04DM	1/2" NPT Filter- Regulator* Auto Drain & Metal Bowl (140 SCFM)	\$146.11
	AW4000-06	3/4" NPT Filter- Regulator* (160 SCFM)	\$101.25
	AW4000-06D	3/4" NPT Filter- Regulator* with Auto Drain (160 SCFM)	\$141.31
	AW4000-06M	3/4" NPT Filter- Regulator* with Metal Bowl (160 SCFM)	\$120.54
	AW4000-06DM	3/4" NPT Filter- Regulator* Auto Drain & Metal Bowl (160 SCFM)	\$160.60
AW5000-10	1" NPT Filter- Regulator* (195 SCFM)	\$120.56	
AW5000-10D	1" NPT Filter- Regulator* with Auto Drain (195 SCFM)	\$160.62	
AW5000-10M	1" NPT Filter- Regulator* with Metal Bowl (195 SCFM)	\$139.86	
AW5000-10DM	1" NPT Filter- Regulator* Auto Drain & Metal Bowl (195 SCFM)	\$179.90	

FRL Mounting Hardware List Price

	Part No.	Description	List Price
	Y20	Spacer for AC2000 / AC2010	\$5.61
	Y30	Spacer for AC3000 / AC3010	\$9.36
	Y40	Spacer for AC4000-04 / AC4010-04	\$11.19
	Y50	Spacer for AC4000-06 / AC4000-06	\$11.19
	Y60	Spacer for AC5000 / AC5010	\$11.67
	Y20L	L-Type Spacer Bracket for AC2000	\$6.10
	Y30L	L-Type Spacer Bracket for AC3000	\$9.36
	Y40L	L-Type Spacer Bracket for AC4000-04	\$11.19
	Y50L	L-Type Spacer Bracket for AC4000-06	\$11.19
	Y60L	L-Type Spacer Bracket for AC5000	\$11.67
	Y20T	T-Type Spacer Bracket for AC2010	\$6.55
	Y30T	T-Type Spacer Bracket for AC3010	\$11.19
	Y40T	T-Type Spacer Bracket for AC4010-04	\$12.14
	Y50T	T-Type Spacer Bracket for AC4010-06	\$13.09
	Y60T	T-Type Spacer Bracket for AC5010	\$18.73
	Y21-N01	Spacer with 1/8 NPT Port for AC2000	\$9.36
	Y21-N02	Spacer with 1/4 NPT Port for AC2000	\$9.36
	Y31-N01	Spacer with 1/8 NPT Port for AC3000	\$14.02
	Y31-N02	Spacer with 1/4 NPT Port for AC3000	\$14.02
	Y41-N02	Spacer with 1/4 NPT Port for AC4000	\$16.82
	Y41-N03	Spacer with 3/8 NPT Port for AC4000	\$18.35
	Y61-N03	Spacer with 3/8 NPT Port for AC5000	\$23.36
Y61-N04	Spacer with 1/2 NPT Port for AC5000	\$29.22	
	B110L	L-Bracket for AC1000	\$5.61
	B210L	L-Bracket for AC2000	\$9.35
	B310L	L-Bracket for AC3000	\$11.19
	B410L	L-Bracket for AC4000	\$11.19
	B510L	L-Bracket for AC4000-06	\$11.67
	B110T	T-Bracket for AC1010	\$6.55
	B210T	T-Bracket for AC2010	\$10.28
	B310T	T-Bracket for AC3010	\$12.14
	B410T	T-Bracket for AC4010	\$13.08
	B510T	T-Bracket for AC4010-06	\$18.69
	B120	Bracket for AR/AW1000	\$2.81
	B220	Bracket for AR/AW2000	\$3.05
	B320	Bracket for AR/AW3000	\$3.75
	B420	Bracket for AR/AW4000-5000	\$4.67
	B240	Bracket for AF/AL2000	\$3.05
	B340	Bracket for AF/AL3000	\$4.11
	B440	Bracket for AF/AL4000-04	\$4.67
	B540	Bracket for AF/AL4000-06	\$5.61
	B640	Bracket for AF/AL5000	\$7.49
	GE 1-60	1" Dia. 1/16" 0-60 PSI back mount pressure gauge for 1000 series FRL	\$9.01
	GE 1-160	1" Dia. 1/16" 0-160 PSI back mount pressure gauge for 1000 series FRL	\$9.01
	GE 1 1/2-30	1 1/2" Dia. 1/8" NPT 0-30 PSI back mount pressure gauge for 2000 series FRL	\$9.01
	GE 1 1/2-60	1 1/2" Dia. 1/8" NPT 0-60 PSI back mount pressure gauge for 2000 series FRL	\$9.01
	GE 1 1/2-160	1 1/2" Dia. 1/8" NPT 0-160 PSI back mount pressure gauge for 2000 series FRL	\$9.01
	GE 2-30	2" Dia. 1/4" NPT 0-30 PSI back mount pressure gauge for 3000-5000 series FRL	\$9.65
	GE 2-60	2" Dia. 1/4" NPT 0-60 PSI back mount pressure gauge for 3000-5000 series FRL	\$9.65
	GE 2-160	2" Dia. 1/4" NPT 0-160 PSI back mount pressure gauge for 3000-5000 series FRL	\$10.67
	GP 1 1/2-160	1 1/2" Dia. 1/8" NPT 0-160 PSI panel mount pressure gauge for 2000 series FRL	\$10.46
	GP 2-160	2" Dia. 1/4" NPT 0-160 PSI panel mount pressure gauge	\$11.11
	GA 1 1/2-60	1.5" Dia. 1/8" NPT 0-60 PSI SS housing back mount glycerin filled	\$15.43
GA 1 1/2-160	1.5" Dia. 1/8" NPT 0-160 PSI SS housing back mount glycerin filled	\$15.43	
	VHS2000-01	1/8" NPT Relieving Shut-off / Lockout Valve for 2000-01 Series FRL	\$32.52
	VHS2000-02	1/4" NPT Relieving Shut-off / Lockout Valve for 2000-02 Series FRL	\$32.52
	VHS3000-02	1/4" NPT Relieving Shut-off / Lockout Valve for 3000-02 Series FRL	\$41.44
	VHS3000-03	3/8" NPT Relieving Shut-off / Lockout Valve for 3000-03 Series FRL	\$41.44
	VHS4000-03	3/8" NPT Relieving Shut-off / Lockout Valve for 4000-03 Series FRL	\$61.75
	VHS4000-04	1/2" NPT Relieving Shut-off / Lockout Valve for 4000-04 Series FRL	\$61.75
	VHS5000-06	3/4" NPT Relieving Shut-off / Lockout Valve for 5000-06 Series FRL	\$126.43
VHS5000-10	1" NPT Relieving Shut-off / Lockout Valve for 5000-10 Series FRL	\$126.43	



Interchangeable with SMC—NAC Series FRL											
Filter-Regulator-Lubricator (AC)		Stacking Filter-Regulator-Lubricator (AC)		Filter-Regulator (AW)		Regulator (AR)		Filters (AF)		Lubricators (AL)	
Model	Air Flow Rate* SCFM (LPM)	Model	Air Flow Rate* SCFM (LPM)	Model	Air Flow Rate* SCFM (LPM)	Model	Air Flow Rate* SCFM (LPM)	Model	Air Flow Rate* SCFM (LPM)	Model	Air Flow Rate* SCFM (LPM)
AC 1000-00	3 (90)	AC 1010-00	3 (90)	AW 1000-00	3 (90)	AR 1000-00	4 (100)	AF 1000-00	4 (110)	AL 1000-00	3 (90)
AC 2000-XX	18 (500)	AC 2010-XX	18 (500)	AW 2000-XX	19 (550)	AR 2000-XX	19 (550)	AF 2000-XX	26 (760)	AL 2000-XX	28 (800)
AC 3000-XX	70 (2000)	AC 3010-XX	60 (1700)	AW 3000-XX	70 (2000)	AR 3000-XX	88 (2500)	AF 3000-XX	70 (2000)	AL 3000-XX	60 (1700)
AC 4000-XX	140 (4000)	AC 4010-XX	105 (3000)	AW 4000-XX	140 (4000)	AR 4000-XX	210 (6000)	AF 4000-XX	140 (4000)	AL 4000-XX	180 (5000)
AC 4000-06	160 (4500)	AC 4010-06	105 (3000)	AW 4000-06	160 (4500)	AR 4000-06	210 (6000)	AF 4000-06	210 (6000)	AL 4000-06	220 (6300)
AC 5000-XX	180 (5000)	AC 5010-XX	140 (4000)	AW 5000-XX	195 (5500)	AR 5000-XX	280 (8000)	AF 5000-XX	245 (7000)	AL 5000-XX	245 (7000)

*Measured with Supply Air Pressure @100PSI and Set Point Pressure @75PSI

Model Series	Port Size	Port Size (Pressure Gauge)	Regulating Range	Max. Operating Pressure	Operating Temperature	Filtration	Bowl Material	Bowl Guard	Body Material	Construction/Regulator	Seals	Filter Drain	Service
1000-00	10-32 (M5)	1/16 Rc (PT)	7 - 100 PSI	150 PSI (9.9 kgf/cm ²)	40 - 140°F (5 - 60°C)	5 Micron Filter (Option); 25 Micron (Standard Sintered Brass Filter)	Polycarbonate (standard) or Aluminum Metal (Option)	N/A	Die-Casting Aluminum	Relieving Type	NBR	Semi-Auto Differential Drain	For Air Only
1010-00								N/A				Semi-Auto Differential Drain (Standard) or Automatic Drain	
2000-XX	1/8 or 1/4 NPT	1/8 NPT	7 - 125 PSI (0.5 - 8.5 kgf/cm ²)	150 PSI (9.9 kgf/cm ²)	40 - 140°F (5 - 60°C)	5 Micron Filter (Option); 25 Micron (Standard Sintered Brass Filter)	Polycarbonate (standard) or Aluminum Metal (Option)	Steel Bowl Guard	Die-Casting Aluminum	Relieving Type	NBR	Semi-Auto Differential Drain (Standard) or Automatic Drain	For Air Only
2010-XX													
3000-XX	1/4 or 3/8 NPT	1/8 NPT	7 - 125 PSI (0.5 - 8.5 kgf/cm ²)	150 PSI (9.9 kgf/cm ²)	40 - 140°F (5 - 60°C)	5 Micron Filter (Option); 25 Micron (Standard Sintered Brass Filter)	Polycarbonate (standard) or Aluminum Metal (Option)	Steel Bowl Guard	Die-Casting Aluminum	Relieving Type	NBR	Semi-Auto Differential Drain (Standard) or Automatic Drain	For Air Only
3010-XX													
4000-XX	3/8 or 1/2 NPT	1/4 NPT	7 - 125 PSI (0.5 - 8.5 kgf/cm ²)	150 PSI (9.9 kgf/cm ²)	40 - 140°F (5 - 60°C)	5 Micron Filter (Option); 25 Micron (Standard Sintered Brass Filter)	Polycarbonate (standard) or Aluminum Metal (Option)	Steel Bowl Guard	Die-Casting Aluminum	Relieving Type	NBR	Semi-Auto Differential Drain (Standard) or Automatic Drain	For Air Only
4010-XX													
4000-06	3/4 NPT	1/4 NPT	7 - 125 PSI (0.5 - 8.5 kgf/cm ²)	150 PSI (9.9 kgf/cm ²)	40 - 140°F (5 - 60°C)	5 Micron Filter (Option); 25 Micron (Standard Sintered Brass Filter)	Polycarbonate (standard) or Aluminum Metal (Option)	Steel Bowl Guard	Die-Casting Aluminum	Relieving Type	NBR	Semi-Auto Differential Drain (Standard) or Automatic Drain	For Air Only
4010-06													
5000-XX	3/4 or 1 NPT	1/4 NPT	7 - 125 PSI (0.5 - 8.5 kgf/cm ²)	150 PSI (9.9 kgf/cm ²)	40 - 140°F (5 - 60°C)	5 Micron Filter (Option); 25 Micron (Standard Sintered Brass Filter)	Polycarbonate (standard) or Aluminum Metal (Option)	Steel Bowl Guard	Die-Casting Aluminum	Relieving Type	NBR	Semi-Auto Differential Drain (Standard) or Automatic Drain	For Air Only
5010-XX													

These FRL components are of modular design with joiner clamps. The joiner clamps allow easy connection and disconnection of FRL components for simple installation and maintenance.

Filter Regulator Lubricator Selection:

1. Determine flow rate requirements.
2. Determine required set point pressure and allowable pressure drop.
3. Locate the FRL graph with set point pressure that provides the flow rate with acceptable pressure drop.

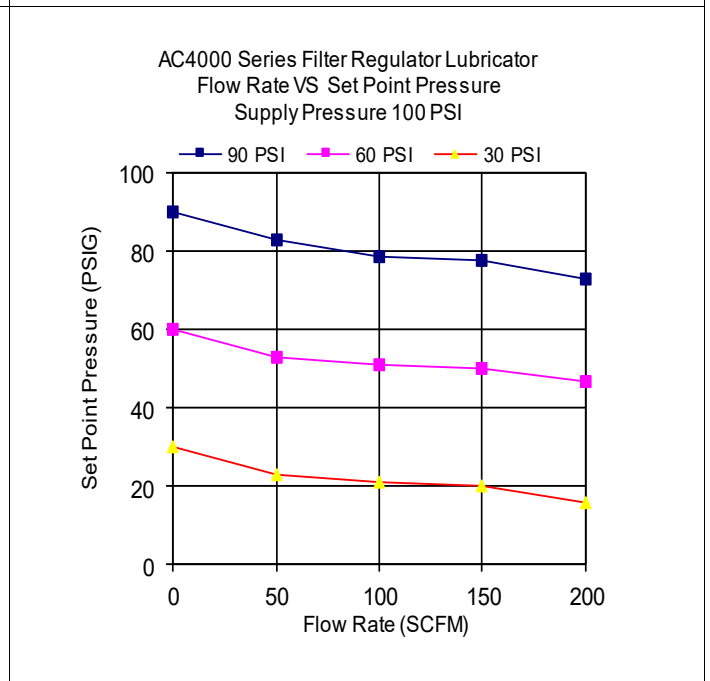
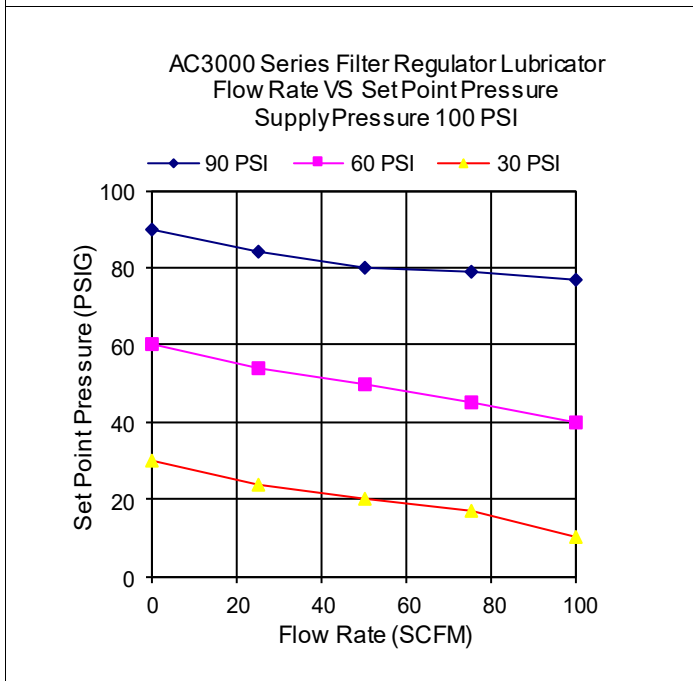
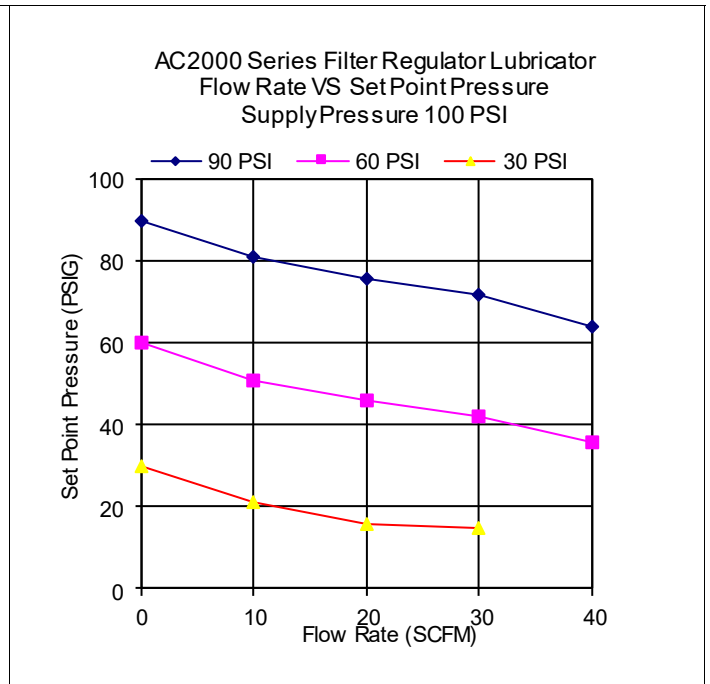
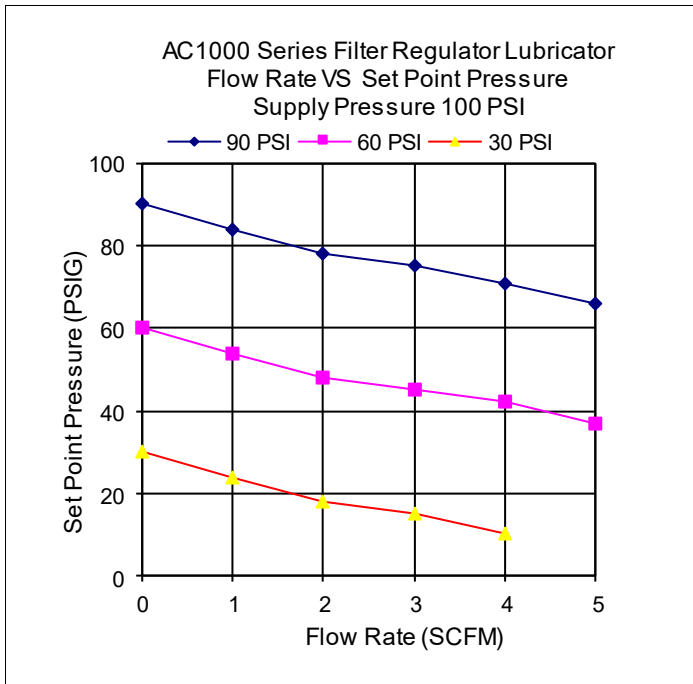
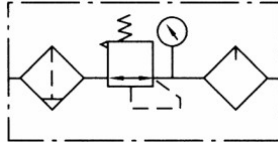



Filter Selection:

1. Determine flow rate requirements.
2. Determine required set point pressure and allowable pressure drop.
3. Locate the FRL graph with set point pressure that provides the flow rate with acceptable pressure drop.

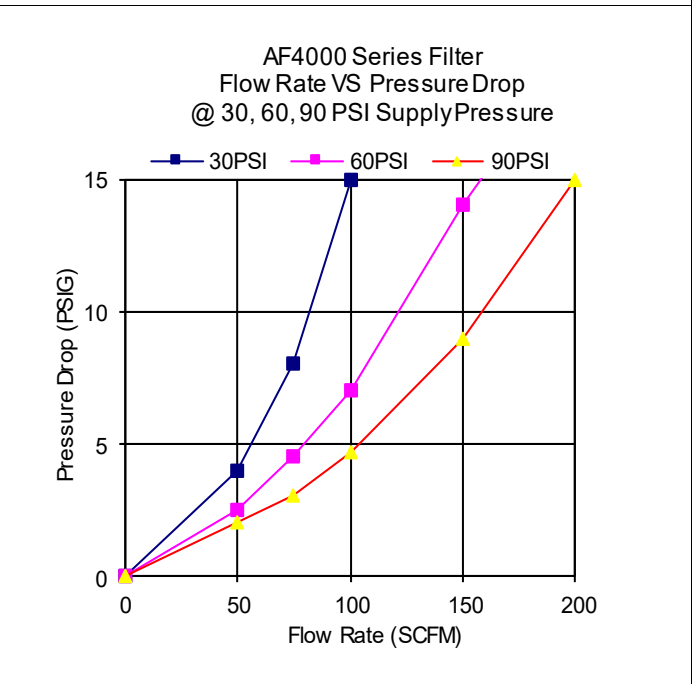
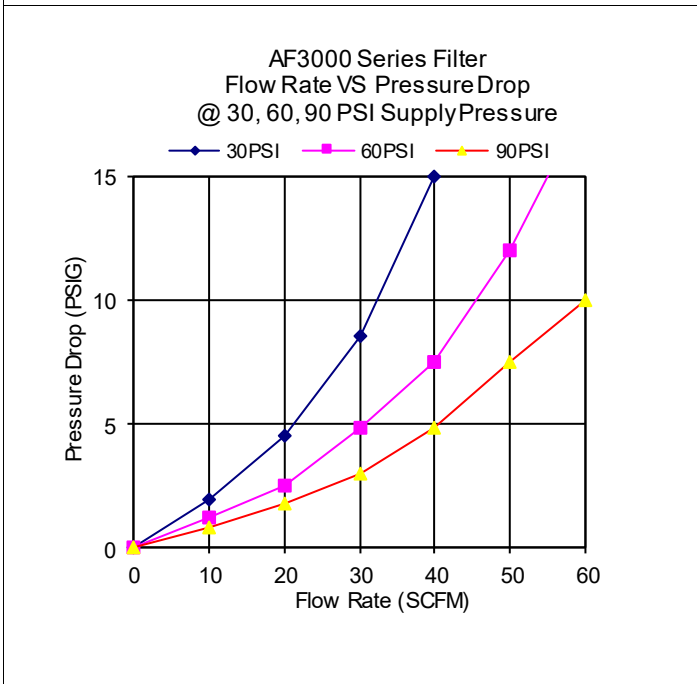
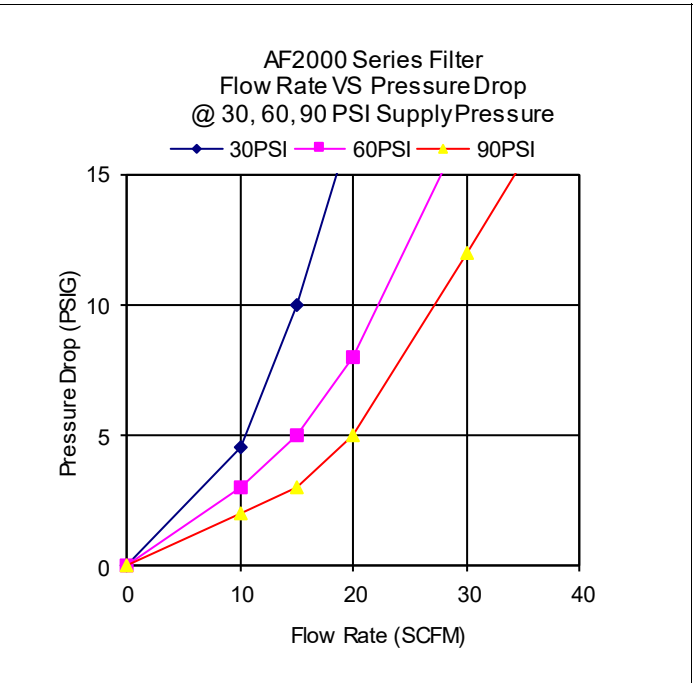
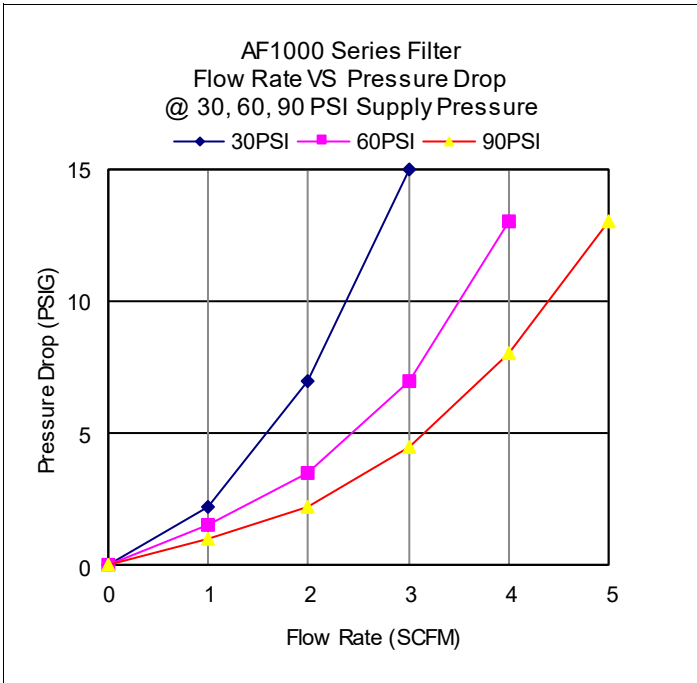
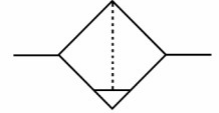

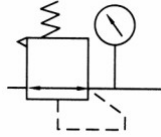

Regulator Selection:

1. Determine flow rate requirements.
2. Determine required set point pressure and allowable pressure drop.
3. Locate the FRL graph with set point pressure that provides the flow rate with acceptable pressure drop.

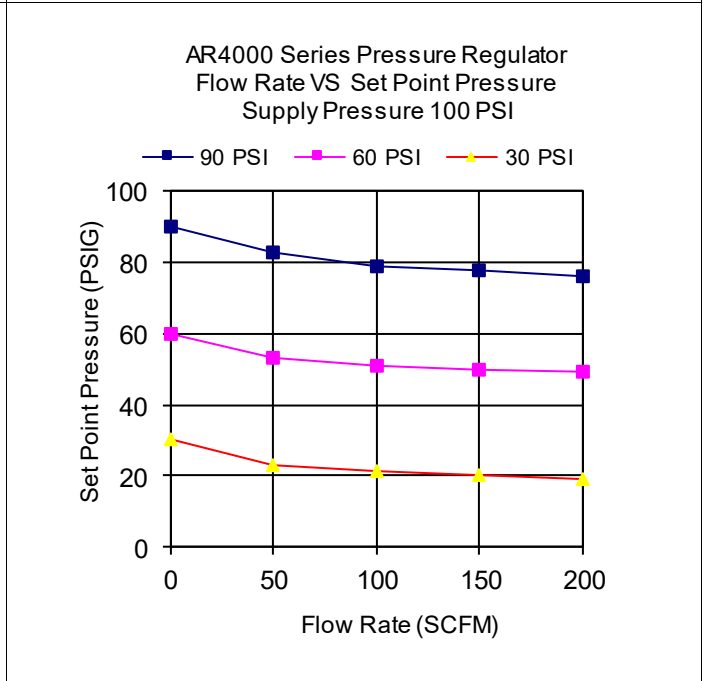
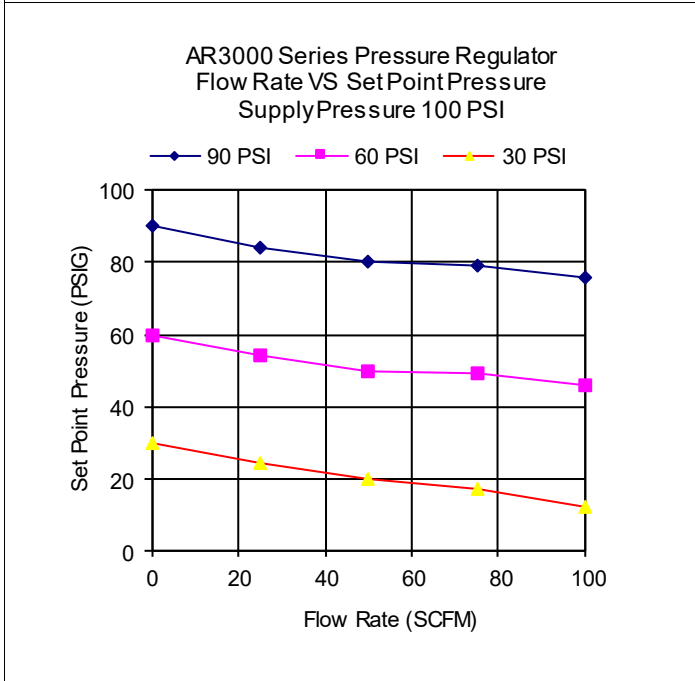
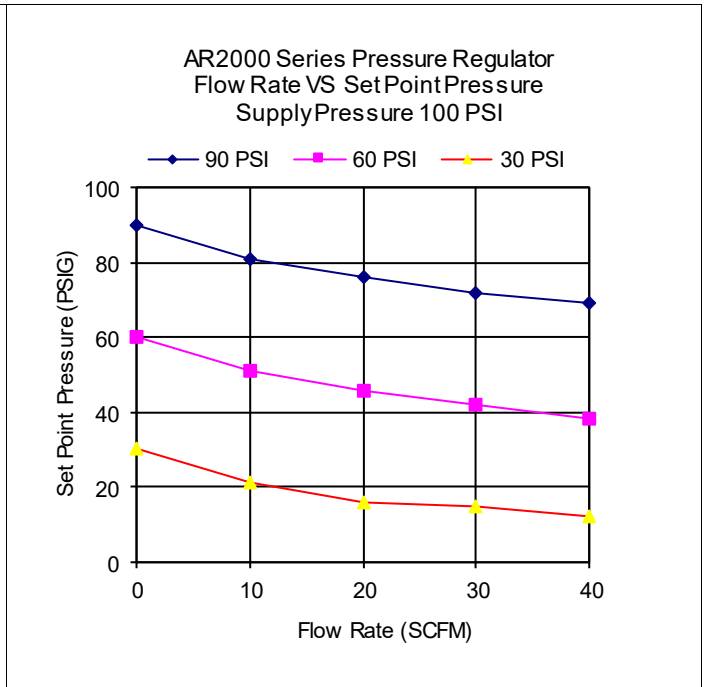
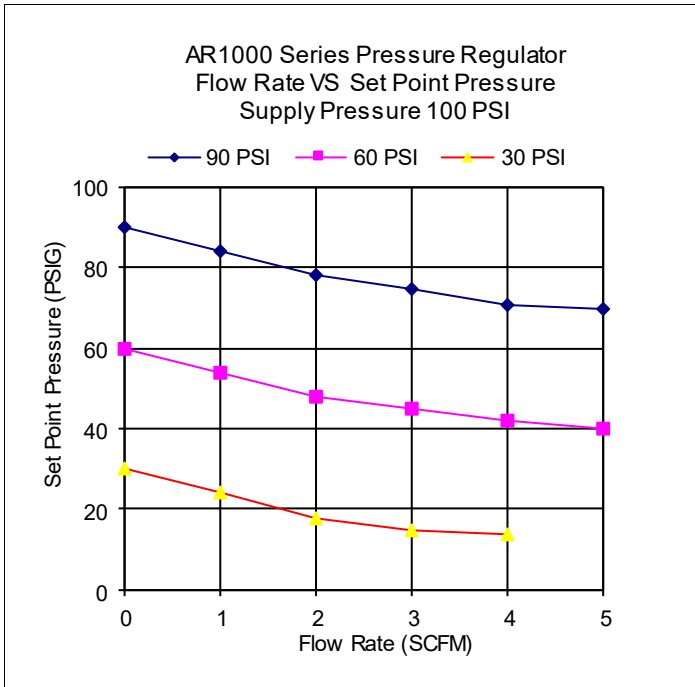



Filter Regulator Selection:

1. Determine flow rate requirements.
2. Determine required set point pressure and allowable pressure drop.
3. Locate the FRL graph with set point pressure that provides the flow rate with acceptable pressure drop.

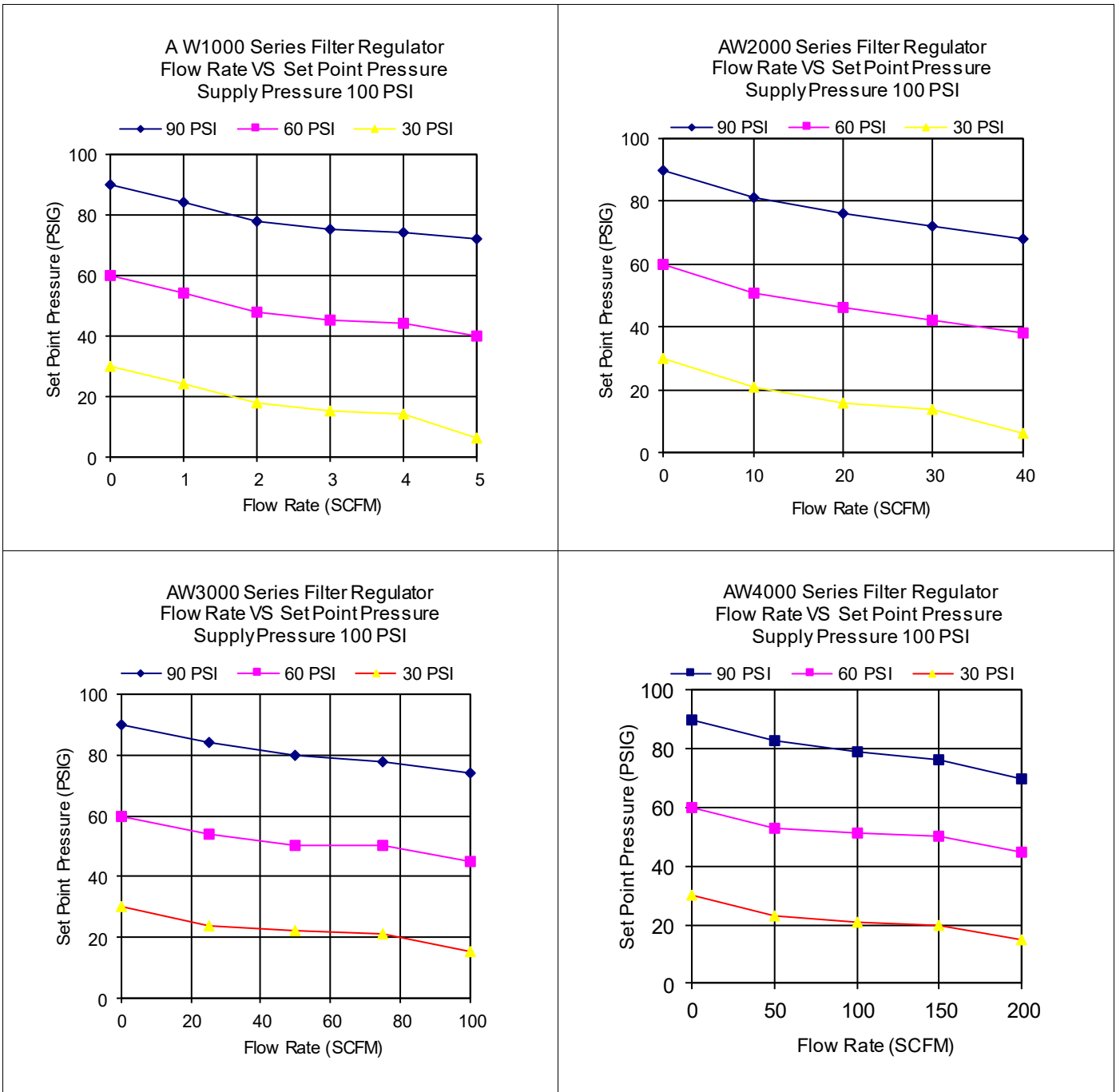
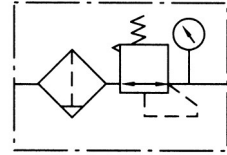

Filter Regulator Lubricator Selection:

1. Determine flow rate requirements.
2. Determine required set point pressure and allowable pressure drop.
3. Locate the FRL graph with set point pressure that provides the flow rate with acceptable pressure drop.

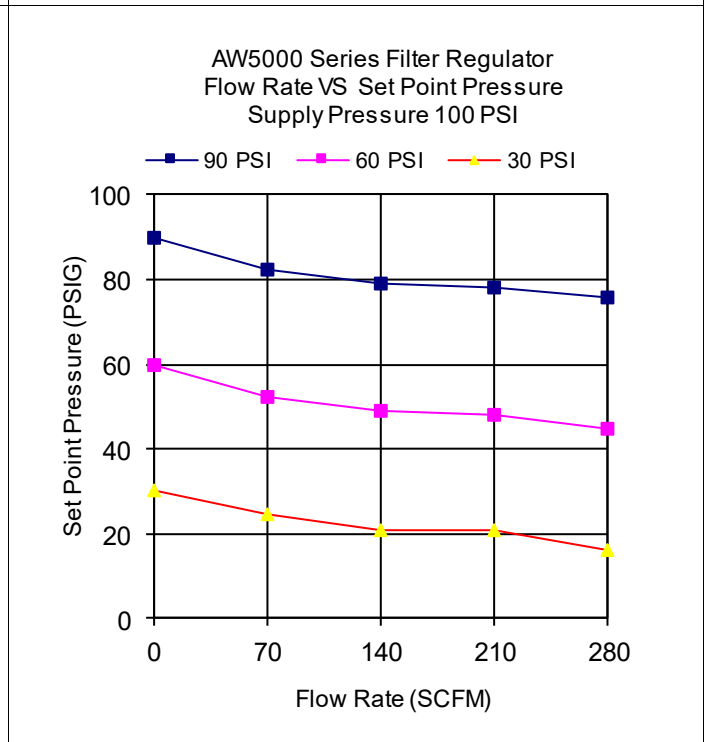
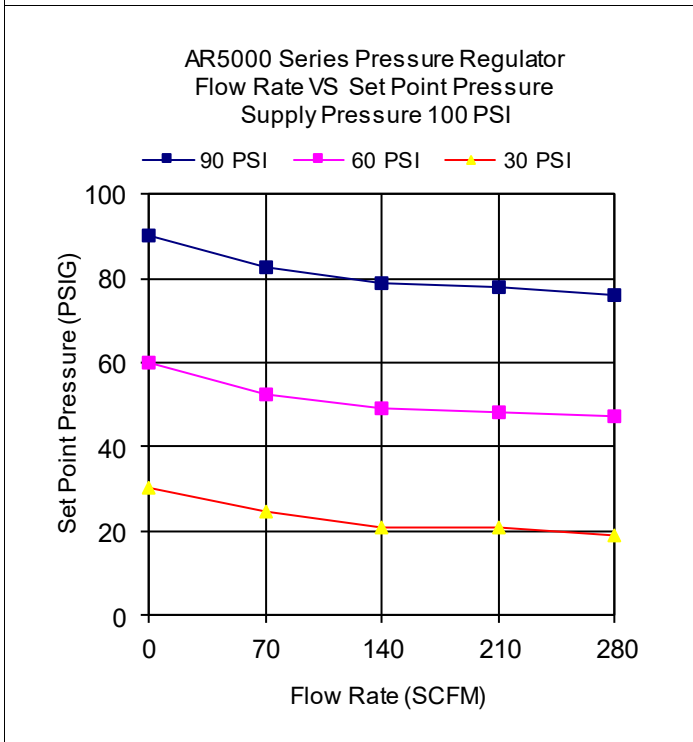
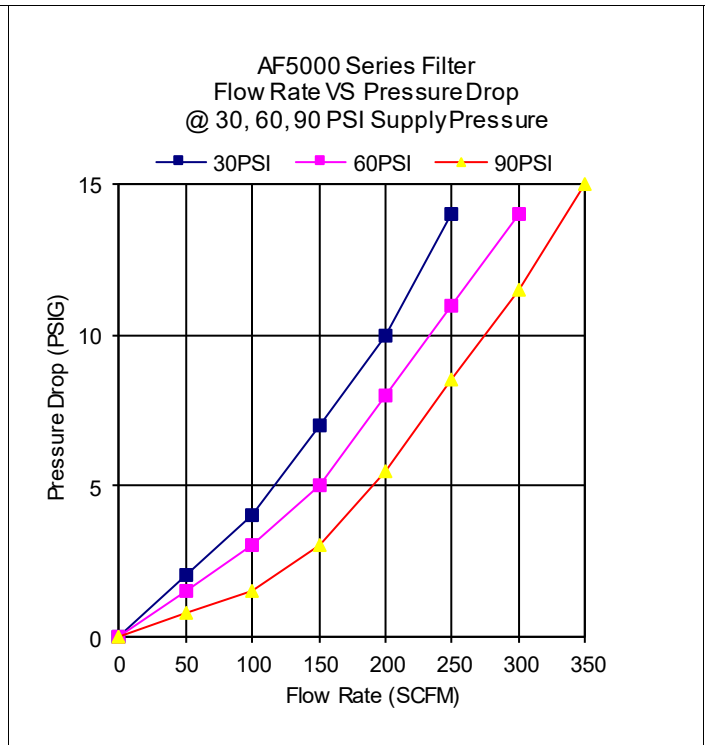
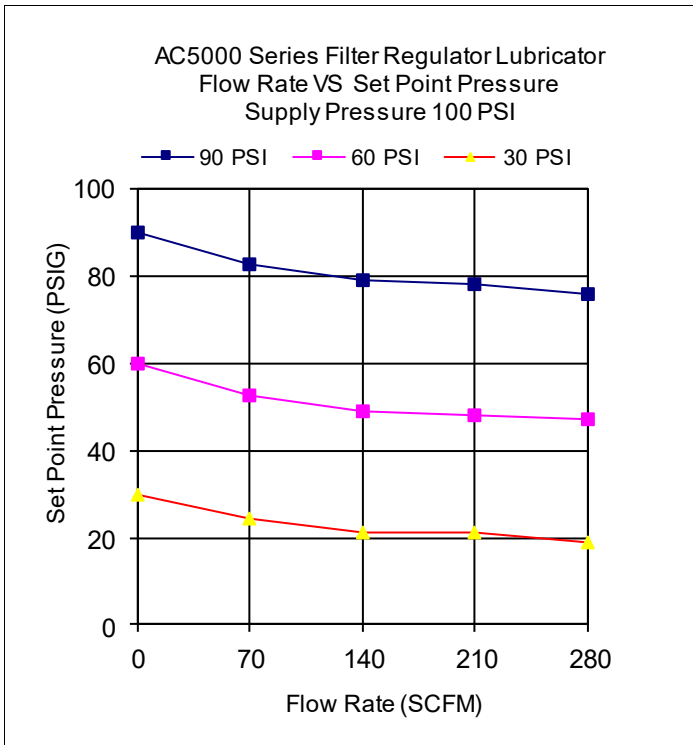

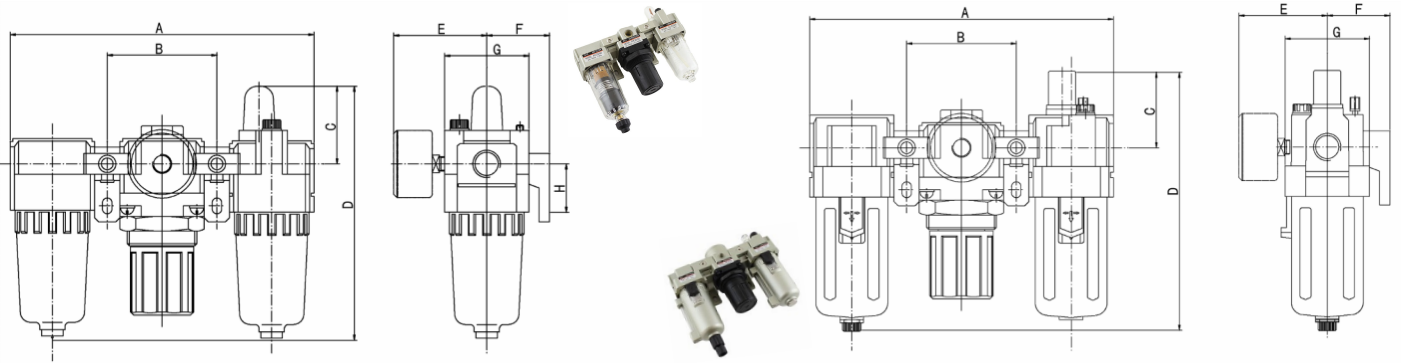

Model	Flow Rate (lpm/scfm)	Port	Gauge Port	A (mm/in)	B (mm/in)	C (mm/in)	D (mm/in)	E (mm/in)	F (mm/in)	G (mm/in)	H (mm/in)	Bracket	Weight (kg/lb)	Gauge
AC1000 -00	90	10-32 (M5)	1/16 Rc	91	33	25.5	84.5	26	25	25	20	Y10L	0.26	GE-1-160-00
	3			3.58	1.30	1.00	3.33	1.02	0.98	0.98	0.79		0.57	
AC2000 -01	500	1/8 NPT	1/8 NPT	140	50	38	125	56.8	30	40	24	Y20L	0.74	GE-1 1/2-160-01
AC2000 -02	18	1/4 NPT		5.51	1.97	1.50	4.92	2.24	1.18	1.57	0.94		1.63	
AC3000 -02	2000	1/4 NPT	1/8 NPT	181	64	38	156.5	60.8	41	53	35	Y30L	1.18	GE-1 1/2-160-01
AC3000 -03	70	3/8 NPT		7.13	2.52	1.50	6.16	2.39	1.69	2.09	1.38		2.60	
AC4000 -03	4000	3/8 NPT	1/4 NPT	238	84	41	191.5	65.5	50	70	40	Y40L	2.14	GE-2-160-02
AC4000 -04	140	1/2 NPT		9.37	3.31	1.61	7.54	2.58	1.97	2.76	1.57		4.71	
AC4000 -06	4500	3/4 NPT	1/4 NPT	253	89	41	193	69.5	50	70	40	Y50L	2.47	GE-2-160-02
	160			9.96	3.50	1.61	7.60	2.74	1.97	2.76	1.57		5.43	
AC5000 -06	5000	3/4 NPT	1/4 NPT	300	105	48	271.5	75.5	69.8	90	50	Y60L	3.82	GE-2-160-02
AC5000 -10	180	1 NPT		11.81	4.13	1.89	10.69	2.97	2.75	3.54	1.97		8.40	

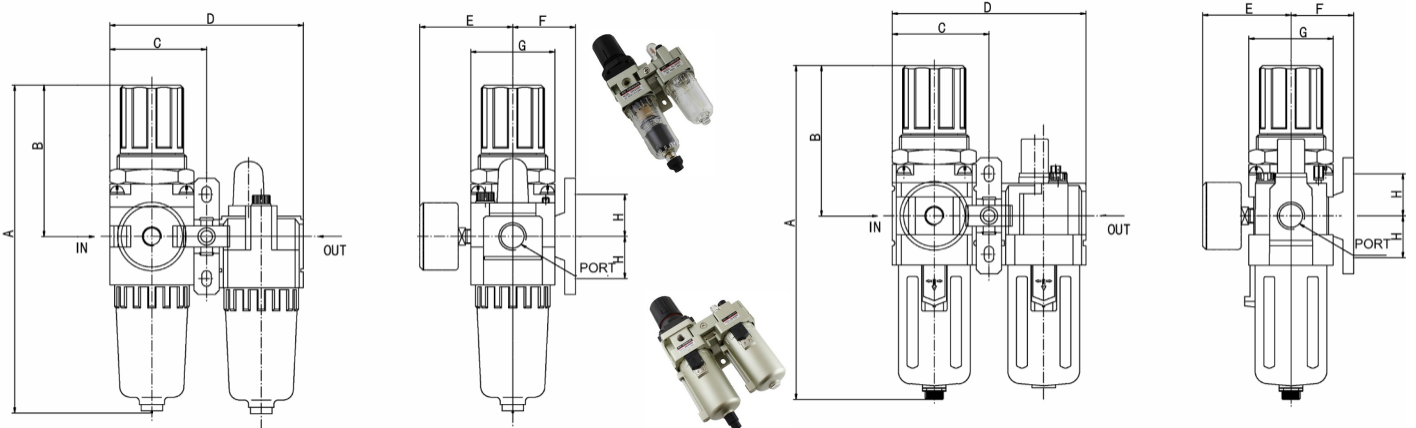

Model	Flow Rate (lpm/scfm)	Port	Gauge Port	A (mm/in)	B (mm/in)	C (mm/in)	D (mm/in)	E (mm/in)	F (mm/in)	G (mm/in)	H (mm/in)	Bracket	Weight (kg/lb)	Gauge
AC1010 -00	90	10-32 (M5)	1/16 Rc	109.5	50.5	29	58	26	25	25	20	Y10T	0.22	GE-1-160-00
	3			4.31	1.99	1.14	2.28	1.02	0.98	0.98	0.79		0.48	
AC2010 -01	500	1/8 NPT	1/8 NPT	164.5	78	45	90	56.8	30	40	24	Y20T	0.66	GE-1 1/2-160-01
AC2010 -02	18	1/4 NPT		6.48	3.07	1.77	3.54	2.24	1.18	1.57	0.94		1.45	
AC3010 -02	1700	1/4 NPT	1/8 NPT	211	92.5	58.5	117	60.8	41	53	35	Y30T	0.98	GE-1 1/2-160-01
AC3010 -03	60	3/8 NPT		8.31	3.64	2.30	4.61	2.39	1.61	2.09	1.38		2.16	
AC4010 -03	3000	3/8 NPT	1/4 NPT	262	112	77	154	65.5	50	70	40	Y40T	1.93	GE-2-160-02
AC4010 -04	105	1/2 NPT		10.31	4.41	3.03	6.06	2.58	1.97	2.76	1.57		4.25	
AC4010-06	3000	3/4 NPT	1/4 NPT	267	114	82	164	69.5	50	70	40	Y50T	1.99	GE-2-160-02
	105			10.51	4.49	3.23	6.46	2.74	1.97	2.76	1.57		4.38	
AC5010 -06	4000	3/4 NPT	1/4 NPT	338	116	97.5	195	75.5	69.8	90	50	Y60T	3.2	GE-2-160-02
AC5010 -10	140	1 NPT		13.31	4.57	3.84	7.68	2.97	2.75	3.54	1.97		7.04	

Air Filter & Regulator Dimensions

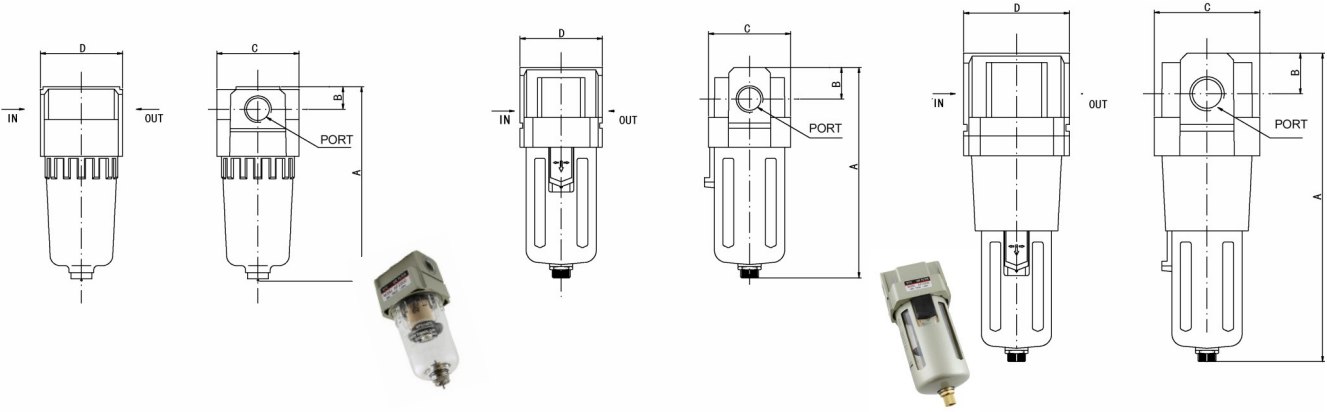

Model	Flow Rate (lpm/scfm)	Port	A (mm/in)	B (mm/in)	C (mm/in)	D (mm/in)	Bracket/Screw	Weight (kg/lb)
AF1000-00	110	10-32 (M5)	66	7	25		B140	0.07
	4		2.60	0.28	0.98	0.00		0.15
AF2000-01	750	1/8 NPT	97.5	11	40	40	B240/M4x8	0.19
AF2000-02	26	1/4 NPT	3.84	0.43	1.57	1.57		0.42
AF3000-02	2000	1/4 NPT	132.5	14	53	53	B340/M4x8	0.29
AF3000-03	70	3/8 NPT	5.22	0.55	2.09	2.09		0.64
AF4000-03	4000	3/8 NPT	168.5	18	70	70	B440/M5x10	0.55
AF4000-04	140	1/2 NPT	6.63	0.71	2.76	2.76		1.21
AF4000-06	6000	3/4 NPT	172.5	20	70	70	B540/M5x10	0.58
	210		6.79	0.79	2.76	2.76		1.28
AF5000-06	7000	3/4 NPT	247.5	24	90	90	B640/M6x10	1.08
AF5000-10	245	1 NPT	9.74	0.94	3.54	3.54		2.38

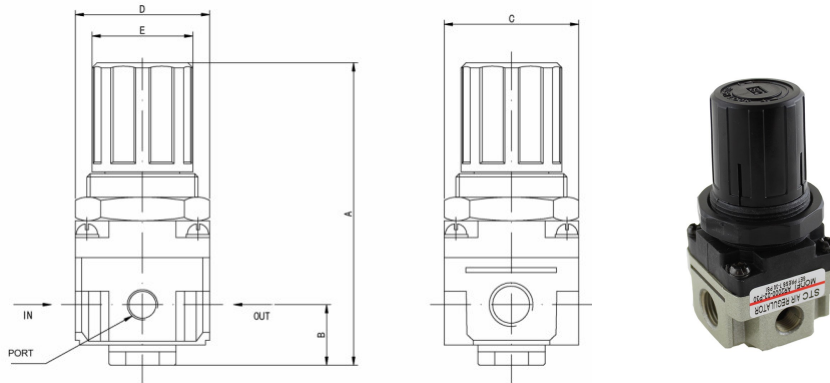

Model	Flow Rate (lpm/scfm)	Port	Gauge Port	A (mm/in)	B (mm/in)	C (mm/in)	D (mm/in)	E (mm/in)	Panel Cut Hole (mm/in)	Bracket	Weight (kg/lb)	Gauge
AR1000-00	100	10-32 (M5)	1/16 Rc	61.5	11	25	25	20	20.5	B120	0.08	GE-1-160-00
	4			2.42	0.43	0.98	0.98	0.79	0.81		0.18	
AR2000-01	550	1/8 NPT	1/8 NPT	95	17	40	40	34	33.5	B220	0.27	GE-1 1/2-160-01
AR2000-02	19	1/4 NPT		3.74	0.67	1.57	1.57	1.34	1.32		0.59	
AR2500-02	2000	1/4 NPT		102.5	25	48	53	34	33.5			
AR2500-03	70	3/8 NPT		4.04	0.98	18.9	2.09	1.34	1.32			
AR3000-02	2500	1/4 NPT	1/8 NPT	127.5	35	53	53	40	42.5	B320	0.41	GE-1 1/2-160-01
AR3000-03	88	3/8 NPT	5.02	1.38	2.09	2.09	1.57	1.67	0.90			
AR4000-03	6000	3/8 NPT	1/4 NPT	149.5	37.5	70	70	54	52.5	B420	0.84	GE-2-160-02
AR4000-04	210	1/2 NPT	5.89	1.48	2.76	2.76	2.13	2.07	1.85			
AR4000-06	6000	3/4 NPT	1/4 NPT	154	40.5	70	75	54	52.5	B420	0.84	GE-2-160-02
	210		6.06	1.59	2.76	2.95	2.13	2.07	1.85			
AR5000-06	8000	3/4 NPT	1/4 NPT	168	48	90	90	54	52.5	B420	1.19	GE-2-160-02
AR5000-10	280	1 NPT	6.61	1.89	3.54	3.54	2.13	2.07	2.62			

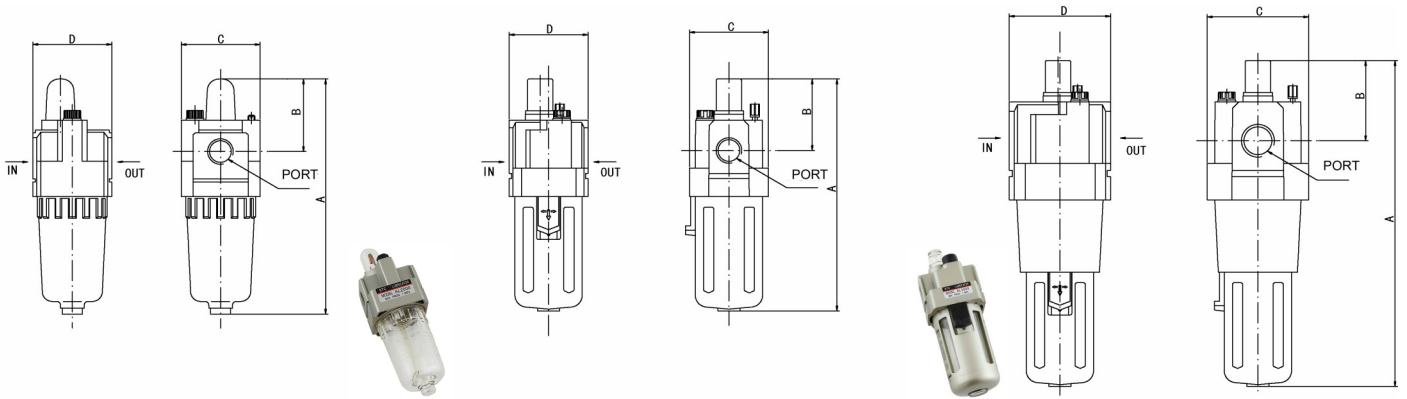

Model	Flow Rate (lpm/scfm)	Port	A (mm/in)	B (mm/in)	C (mm/in)	D (mm/in)	Bracket/Screw	Weight (kg/lb)
AL1000-00	95	10-32 (M5)	81.5	25.5	25		B140	0.07
	3		3.21	1.00	0.98			0.15
AL2000-01	800	1/8 NPT	122	38	40	40	B240/M4x8	0.22
AL2000-02	28	1/4 NPT	4.80	1.50	1.57	1.57		0.48
AL3000-02	1700	1/4 NPT	142	38	53	53	B340/M4x8	0.3
AL3000-03	60	3/8 NPT	5.59	1.50	2.09	2.09		0.66
AL4000-03	5000	3/8 NPT	177	41	70	70	B440/M5x10	0.56
AL4000-04	180	1/2 NPT	6.97	1.61	2.76	2.76		1.23
AL4000-06	6300	3/4 NPT	177	39	70	70	B540/M5x10	0.58
	220		6.97	1.54	2.76	2.76	1.28	
AL5000-06	7000	3/4 NPT	254	45	90	90	B640/M6x10	1.08
AL5000-10	245	1 NPT	10.00	1.77	3.54	3.54		2.38

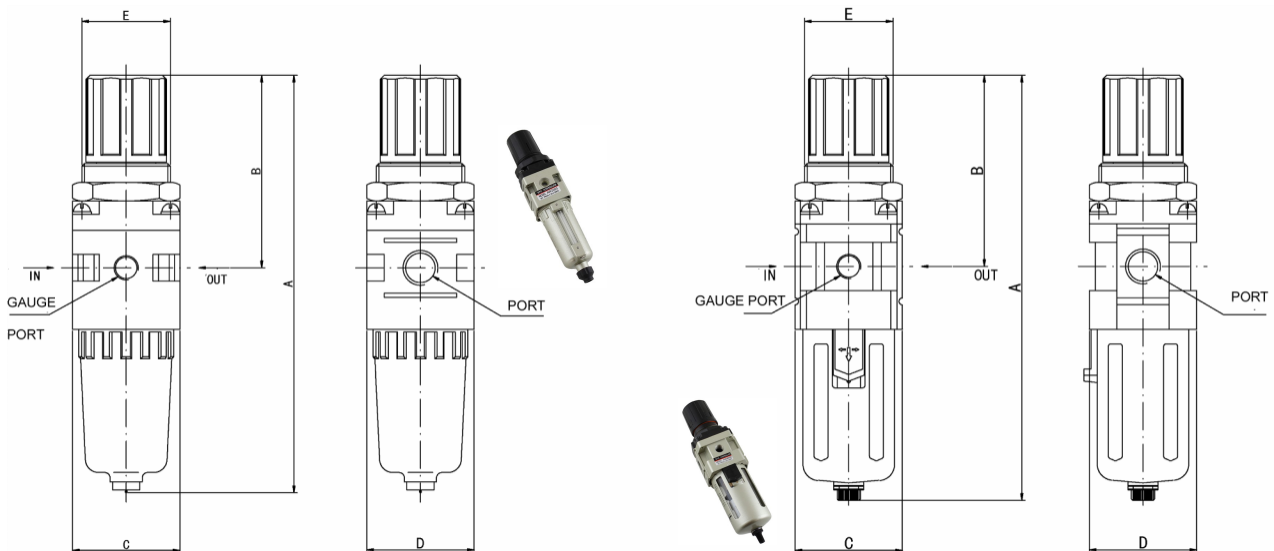

Model	Flow Rate (lpm/scfm)	Port	Gauge Port	A (mm/in)	B (mm/in)	C (mm/in)	D (mm/in)	E (mm/in)	Panel Cut Hole (mm/in)	Bracket	Weight (kg/lb)	Gauge
AW1000-00	90	10-32 (M5)	1/16 Rc	109.5	50.5	25	28	20	20.5	B120	0.09	GE-1-160-00
	3			4.31	1.99	0.98	1.10	1.10	0.81		0.20	
AW2000-01	550	1/8 NPT	1/8 NPT	164.5	78	40	40	34	33.5	B220	0.36	GE-1 1/2-160-01
AW2000-02	19	1/4 NPT		6.48	3.07	1.57	1.57	1.34	1.32		0.79	
AW3000-02	2000	1/4 NPT	1/8 NPT	211	92.5	53	53	40	33.5	B320	0.56	GE-1 1/2-160-01
AW3000-03	70	3/8 NPT	1/8 NPT	8.31	3.64	2.09	2.09	1.57	1.32		1.23	
AW4000-03	4000	3/8 NPT	1/4 NPT	262	112	70	70	54	42.5	B420	1.15	GE-2-160-02
AW4000-04	140	1/2 NPT		10.31	4.41	2.76	2.76	2.13	1.67		2.53	
AW4000-06	4500	3/4 NPT	1/4 NPT	267	114	70	75	54	42.5	B520	1.21	GE-2-160-02
	160			10.51	4.49	2.76	2.95	2.13	1.67		2.66	
AW5000-06	5500	3/4 NPT	1/4 NPT	338	116	90	90	54	42.5	B620	1.7	GE-2-160-02
AW5000-10	195	1 NPT		13.31	4.57	3.54	3.54	2.13	1.67		3.74	

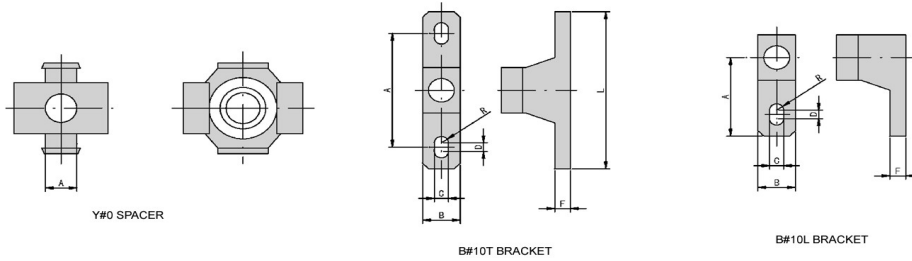

Spacer

T Bracket

L Bracket

L Bracket	L Spacer Bracket	For	T Bracket	T Spacer Bracket	For	A	B	C	D	E	F	G	H	R	L
B110L	Y10L	AC1000	B110T	Y10T	AC1010	20	12	4.5	3	2.5	5	8	40	2.25	27
B210L	Y20L	AC2000	B210T	Y20T	AC2010	24	15	5.5	3	30	5	10	48	2.75	33
B310L	Y30L	AC3000	B310T	Y30T	AC3010	35	16	7	4	41	7	11	70	3.5	45
B410L	Y40L	AC4000	B410T	Y40T	AC4010	40	22	9	4	50	7	14	80	4.5	50
B510L	Y50L	AC4000-06	B510T	Y50T	AC4010-06	40	22	9	4	50	7	14	80	4.5	50
B610L	Y60L	AC5000	B610T	Y60T	AC5010	50	23	12	4	69.8	10.5	15	100	6	63

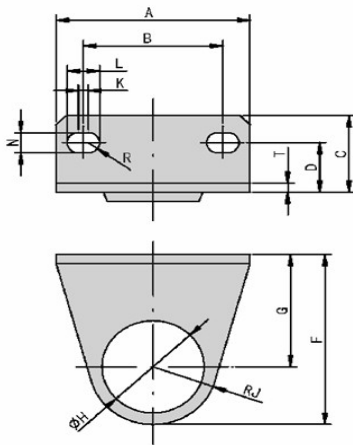

B#20 -Bracket for AR & AW

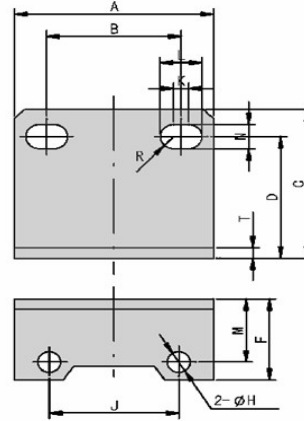

B#40 Bracket for AF/AL

Bracket	A	B	C	D	F	G	H	J	K	L	M	N	R	t	Mounting Screw	For
B120	40	28	17	11	37.8	25	20.5	12.3	2	6.5		4.5	2.25	2		AR/AW1000
B220	55	34	35	19	50	30	33.5	20	10	5.4		5.4	2.7	2.3		AR/AW2000-2500
B320	53	40	21.5	14	64	39	42.5	25	1.5	6.5		6.5	3.25	2.3		AR/AW3000
B420	70	54	27	18	79.2	49.2	52.5	30	2	8.5		8.5	4.25	2.3		AR/AW4000-5000
B240	40	27	33	27	18		4.5	26	3	8.4	14	5.4	2.7	2.3	M4X8	AF/AL2000
B340	53	40	39	32	22.5		4.5	35	1.5	8	19	6.5	3.25	2.3	M4X8	AF/AL3000
B440	70	54	47	38	31.5		5.5	47	2	10.5	20	8.5	4.25	2.3	M5X10	AF/AL4000-04
B540	70	54	47	38	31.5		5.5	47	2	10.5	20	8.5	4.25	2.3	M5X10	AF/AL4000-06
B640	90	66	64	52	43		6.5	60	2	13	29	11	5.5	3.2	M6X10	AF/AL5000

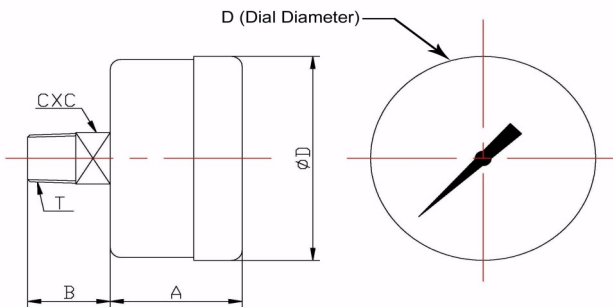

Pressure Gauge Part No.	For	(in/mm)				
		T Port Size	A	B	C	D
GE-1-160-00	AR1000	R1/16 (PT)	0.6/15.3	0.4/10	0.47/12	1.0/25.4
GE-1 1/2-160-01	AR2000-3000	1/8 NPT	0.93/23.8	0.67/17.0	0.43/11	1.6/42
GE-2-160-02	AR4000-5000	1/4 NPT	0.97/24.8	0.77/19.7	0.54/14	2.1/52.4



Precision Engineered

Fine Quality



Advanced Design

Excellent Prices



Contents | Solenoid Valve Numbering System

Contents

Solenoid Valve Numbering System.....	F2
Manifold Numbering System.....	F2
Air Solenoid Valve & Coils List Price.....	F3
Air Pilot Valve & Manifold List Price.....	F4
Specifications.....	F5
Air Solenoid Valve & Air Pilot Valve Dimensions.....	F6 - F8
Manifold Dimensions.....	F8

STC Solenoid Valve Numbering System

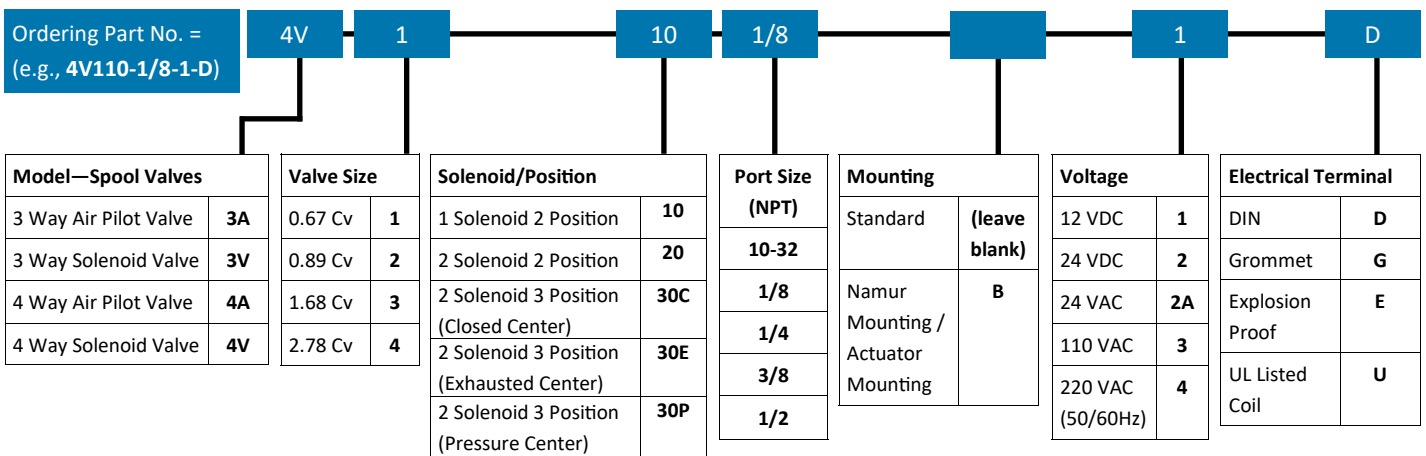

STC Manifold Numbering System

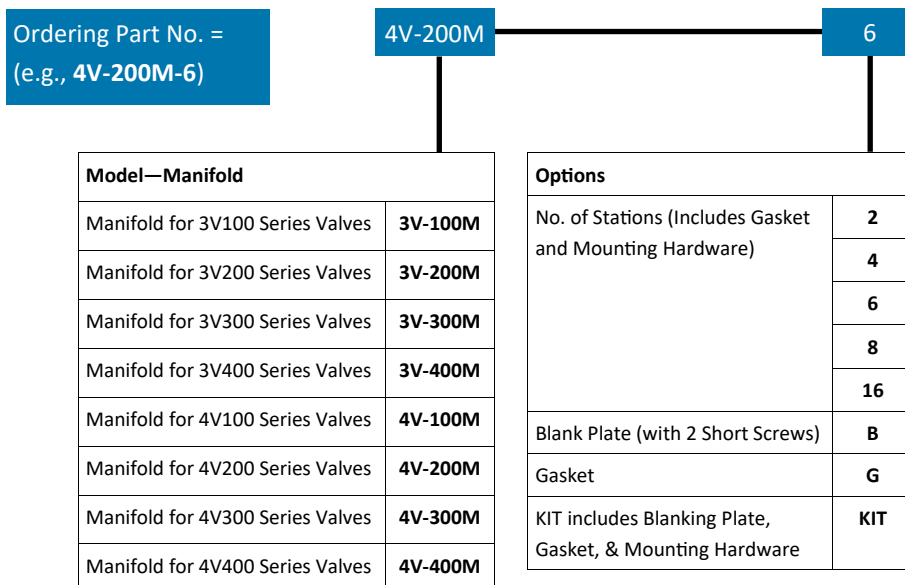





	Part No.	Price	Port Size (NPT)	Voltage Options	Electrical Terminal Options	# Way / Port / Position / Solenoid	Cv	Power	
	2V1-1/8	\$27.48	1/8	1 = 12VDC 2 = 24VDC 2A = 24VAC 3 = 110VAC 4 = 220VAC (50/60Hz)	D = DIN (with LED indicator & conduit terminal)	2/2/2/1	0.23	3W to 6.5W	
	3V1-1/8	\$27.48	1/8			3/2/2/1 Direct Acting	0.05		
	3V110-1/8	\$35.44	1/8		G = Grommet (12" Lead Wire)	E = Explosion Proof	3/3/2/1	0.67	3W to 4.8W
	3V210-1/4	\$35.44	1/4					0.89	
	3V310-1/4	\$47.73	1/4					1.68	
	3V310-3/8	\$47.73	3/8					1.68	
	3V410-1/2	\$83.17	1/2					2.79	
	3V120-1/8	\$54.26	1/8		D = DIN (with LED indicator & conduit terminal)		3/3/2/2	0.67	3W to 4.8W
	3V220-1/4	\$54.26	1/4					0.89	
	3V320-3/8	\$66.53	3/8					1.68	
	3V420-1/2	\$116.44	1/2		G = Grommet (12" Lead Wire)		4/5/2/1	2.79	3W to 4.8W
	4V110-10-32	\$36.89	10-32					0.67	
	4V110-1/8	\$36.89	1/8					0.67	
	4V210-1/4	\$35.44	1/4, 1/8 (Exh)					0.89	
	4V310-1/4	\$47.73	1/4					1.68	
	4V310-3/8	\$47.73	3/8, 1/4 (Exh)		2A = 24VAC	E = Explosion Proof	4/5/2/2	1.68	3W to 4.8W
	4V410-1/2	\$83.17	1/2					0.67	
	3V310-1/4B	\$54.99	1/4					0.89	
	3V310-3/8B	\$54.99	3/8					1.68	
	4V210-1/4B	\$42.64	1/4					1.68	
	4V320-1/4B	\$81.16	1/4		3 = 110VAC		4/5/2/2	0.67	3W to 4.8W
	4V120-1/8	\$54.26	1/8					0.89	
	4V220-1/4	\$54.26	1/4, 1/8(Exh)					1.68	
	4V320-1/4	\$66.54	1/4					1.68	
	4V320-3/8	\$66.54	3/8, 1/4 (Exh)					2.79	
	4V420-1/2	\$116.44	1/2		4 = 220VAC (50/60Hz)	D = DIN (with LED indicator & conduit terminal)	4/5/3/2 Closed Center	0.5	3W to 4.8W
	4V130C-1/8	\$108.92	1/8					0.67	
	4V230C-1/4	\$112.14	1/4, 1/8 (Exh)					1	
	4V330C-3/8	\$129.46	3/8, 1/4 (Exh)	1.68				2.5W	
	4V430C-1/2	\$166.35	1/2	0.5					
	4V130E-1/8	\$108.92	1/8	0.67					
	4V230E-1/4	\$112.14	1/4, 1/8 (Exh)	1				3W to 4.8W	
	4V330E-3/8	\$129.46	3/8, 1/4 (Exh)	1.68					
	4V430E-1/2	\$166.35	1/2	0.5					
	4V130P-1/8	\$108.92	1/8	4/5/3/2 Pressure Center				G = Grommet (12" Lead Wire)	4/5/3/2 Exhaust Center
4V230P-1/4	\$112.14	1/4, 1/8 (Exh)	1						
4V330P-3/8	\$129.46	3/8, 1/4 (Exh)	0.5						
4V430P-1/2	\$166.35	1/2	0.67						
	2P025-1/8	\$26.92	1/8	D = DIN (with LED indicator & conduit terminal)		2/2/2/1 Direct Acting	0.23	3W to 6.5W	
	2P025-1/4	\$26.92	1/4						
	2V025-1/8	\$27.48	1/8	G = Grommet (12" Lead Wire)	E = Explosion Proof	2/2/2/1 Direct Acting	0.23	3W to 6.5W	
	2V025-1/4	\$27.48	1/4				0.23		
	2V035-1/8	\$27.48	1/8				0.5		
	2V035-1/4	\$27.48	1/4				0.5		

	Part No.	Price	Voltage Options	Electrical Connection Options	Power	Specifications	How to connect coils
	100C	\$11.59	1 = 12VDC 2 = 24VDC 2A = 24VAC 3 = 110VAC 4 = 220VAC (50/60Hz)	D = DIN (with LED indicator, conduit terminal)	2.5W	Insulation: F Class IP65 Duty Cycle: 100% ED CE Certification	To Connect DIN Coil: 1) Remove the Philip screw from the plastic housing and unplug it from the DIN coil. 2) From the screw opening, use the screw to push the terminal block out of the plastic housing.
	200C	\$11.59					
	100C	\$11.59	1 = 12VDC 2 = 24VDC 2A = 24VAC 3 = 110VAC 4 = 220VAC (50/60Hz)	G = Grommet (12" Lead Wire)	2.5W	Insulation: F Class IP65 Duty Cycle: 100% ED CE Certification	3) Note the 1, 2, and ground markings on underside of DIN enclosure. 4) For DC DIN Coil, connect 1 to Positive, 2 to Negative. 5) For AC DIN Coil, connect 1 to HOT wire, 2 to Neutral wire, and if required, connect ground to ground wire
	200C	\$11.59					
	200C	\$125.35	1E = 12VDC 2E = 24VDC 2AE = 24VAC 3E = 110VAC 4E = 220VAC (50/60Hz)	Explosion Proof Coil Option: All voltages with 1/2" NPT conduit connection FM Approved. CL. I; ZONE 1, CL. I; DIV. 1; GR. A, B, C, D CL. II; GR. E, F, G- CL. III T4 Ta = -20°C...60°C		Insulation: F Class IP65 Duty Cycle: 100% ED FM Certification	To Connect Grommet Coil: 1) For DC Coil, connect one of the two wires to Positive and the other wire to Negative. 2) For AC Coil, connect one of the two wires to HOT wire, and the other wire to Neutral wire.

Air Pilot Valve & Manifold List Prices Specifications

Air Pilot Valve List Price

	Part No.	Price	Port Size (NPT)	# Ways/Port/Position/Pilot	Cv		Part No.	Price	Port Size (NPT)	# Ways/Port/Position/Pilot	Cv
	3A110-1/8	\$27.48	1/8	3/3/2/1	0.67		4A130C-1/8	\$71.59	1/8	4/5/3/2 Closed Center	0.5
	3A210-1/4	\$27.48	1/4, 1/8 (Exh)		0.89		4A230C-1/4	\$90.89	1/4, 1/8 (Exh)		0.67
	3A310-3/8	\$33.28	3/8, 1/4 (Exh)		1.68		4A330C-3/8	\$104.88	3/8, 1/4 (Exh)		1
	3A410-1/2	\$54.99	1/2		2.79		4A430C-1/2	\$124.71	1/2		1.68
	3A120-1/8	\$34.72	1/8	3/3/2/2	0.67		4A130P-1/8	\$71.59	1/8	4/5/3/2 Pressure Center	0.5
	3A220-1/4	\$35.44	1/4, 1/8 (Exh)		0.89		4A230P-1/4	\$90.89	1/4, 1/8 (Exh)		0.67
	3A320-3/8	\$41.95	3/8, 1/4 (Exh)		1.68		4A330P-3/8	\$104.88	3/8, 1/4 (Exh)		1
	3A420-1/2	\$71.59	1/2		2.79		4A430P-1/2	\$124.71	1/2		1.68
	4A110-1/8	\$27.48	1/8	4/5/2/1	0.67		4A130E-1/8	\$71.59	1/8	4/5/3/2 Exhaust Center	0.5
	4A210-1/4	\$27.48	1/4, 1/8 (Exh)		0.89		4A230E-1/4	\$90.89	1/4, 1/8 (Exh)		0.67
	4A310-3/8	\$33.28	3/8, 1/4 (Exh)		1.68		4A330E-3/8	\$104.88	3/8, 1/4 (Exh)		1
	4A410-1/2	\$54.99	1/2		2.79		4A430E-1/2	\$124.71	1/2		1.68
	4A120-1/8	\$34.72	1/8	4/5/2/2	0.67						
	4A220-1/4	\$35.44	1/4, 1/8 (Exh)		0.89						
	4A320-3/8	\$41.95	3/8, 1/4 (Exh)		1.68						
	4A420-1/2	\$71.59	1/2		2.79						
	3A310B-1/4	\$41.61	1/4	3/3/2/1	1.68						
	3A320B-1/4	\$50.30	1/4	3/3/2/2	1.68						
	4A310B-1/4	\$44.42	1/4	4/5/2/1	1.68						
	4A320B-1/4	\$53.08	1/4	4/5/2/2	1.68						

Integrated Aluminum Base Mounted Manifolds*

To order, please specify the part number and the number of stations (order valve separately).

Part No.	No. of Stations	Price	Description	Part No.	No. of Stations	Price	Description
3V-100M-2	2	\$16.08	Integrated Base for Mounting 3V100 or 3A100 series Solenoid Valves	4V-100M-2	2	\$16.08	Integrated Base for Mounting 4V100 or 4A100 series Solenoid Valves
3V-100M-4	4	\$32.15		4V-100M-4	4	\$32.15	
3V-100M-6	6	\$48.21		4V-100M-6	6	\$48.21	
3V-100M-8	8	\$64.27		4V-100M-8	8	\$64.27	
3V-100M-16	16	\$128.57		4V-100M-16	16	\$128.57	
3V-100M-B	blank plate	\$7.06		4V-100M-B	blank plate	\$7.06	
3V-100M-G	gasket	\$3.22		4V-100M-G	gasket	\$3.22	
3V-200M-2	2	\$16.08		Integrated Base for Mounting 3V200 or 3A200 series Solenoid Valves	4V-200M-2	2	
3V-200M-4	4	\$32.15	4V-200M-4		4	\$32.15	
3V-200M-6	6	\$48.21	4V-200M-6		6	\$48.21	
3V-200M-8	8	\$64.27	4V-200M-8		8	\$64.27	
3V-200M-16	16	\$128.57	4V-200M-16		16	\$128.57	
3V-200M-B	blank plate	\$7.06	4V-200M-B		blank plate	\$7.06	
3V-200M-G	gasket	\$3.22	4V-200M-G		gasket	\$3.22	
3V-300M-2	2	\$24.12	Integrated Base for Mounting 3V300 or 3A300 series Solenoid Valves		4V-300M-2	2	\$24.12
3V-300M-4	4	\$48.21		4V-300M-4	4	\$48.21	
3V-300M-6	6	\$72.33		4V-300M-6	6	\$72.33	
3V-300M-8	8	\$96.43		4V-300M-8	8	\$96.43	
3V-300M-16	16	\$192.85		4V-300M-16	16	\$192.85	
3V-300M-B	blank plate	\$7.06		4V-300M-B	blank plate	\$7.06	
3V-300M-G	gasket	\$3.22		4V-300M-G	gasket	\$3.22	
3V-400M-2	2	\$40.17		Integrated Base for Mounting 3V400 or 3A400 series Solenoid Valves	4V-400M-2	2	\$40.17
3V-400M-4	4	\$80.37	4V-400M-4		4	\$80.37	
3V-400M-6	6	\$120.54	4V-400M-6		6	\$120.54	
3V-400M-8	8	\$160.72	4V-400M-8		8	\$160.72	
3V-400M-16	16	\$321.43	4V-400M-16		16	\$321.43	
3V-400M-B	blank plate	\$7.06	4V-400M-B		blank plate	\$7.06	
3V-400M-G	gasket	\$3.22	4V-400M-G		gasket	\$3.22	

* Includes mounting hardware and seals

Specifications

Valve Type	3A & 4A 100-400 Series Valves	3V & 4V 100-400 Series Valves	2V025-035, 2P025 Series Valves	2V1, 3V1 Series Valves
Port & Mounting	Body Ported, Manifold Mounted	Body Ported, Manifold Mounted	Body Ported, Stacking or Manifold Mounted	Body Ported, Stacking or Manifold Mounted
Action & Motion	Air Pilot, Spool Design	Internal Pilot, Spool Design	Direct Acting	Direct Acting
Operating Pressure	0 to 115 PSI	21 to 115 PSI	Vacuum to 115 PSI	Vacuum to 115 PSI
Coil Insulation & Protection Class	N/A	F Class, IP65 (CE Certification)	F Class, IP65 (CE Certification)	F Class, IP65 (CE Certification)
Coil Duty Cycle	100% ED	100% ED	100% ED	100% ED
Manual Override	N/A	Non-Locking: 100 series, Locking: 200 to 400 series	Non-Locking	Non-Locking
Electrical Connection	N/A	D = DIN (with LED indicator, conduit terminal), G = Grommet (12" - 18" Lead Wire)		
Working Medium	40 micron filtered air or inert gas	40 micron filtered air or inert gas	40 micron filtered air, inert gas & liquid, non-corrosive liquid	
Maximum Pressure	180 PSI @ 75 Deg. F			
Operating Temperature	14 to 140 Deg. F (-10 to 60 Deg. C)			
Body Material	Aluminum (Engineered Plastic for 2P Series)			
Seal Material	NBR (Buna N)			
Lubrication	Not Required			
Service	Air			

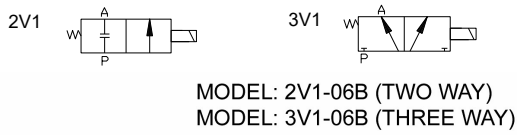
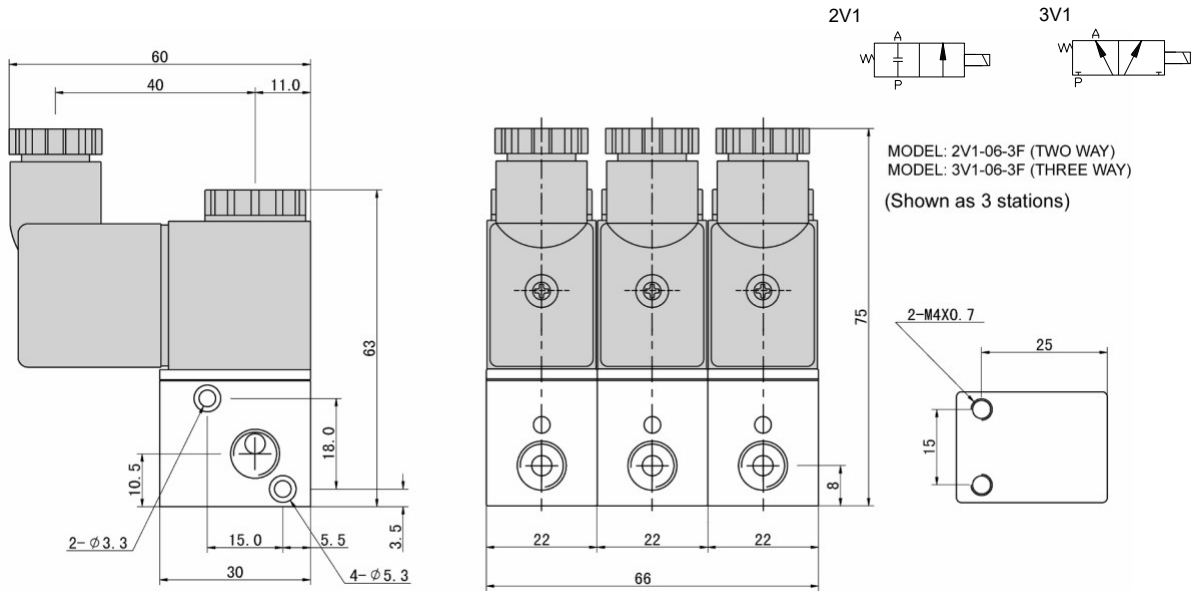
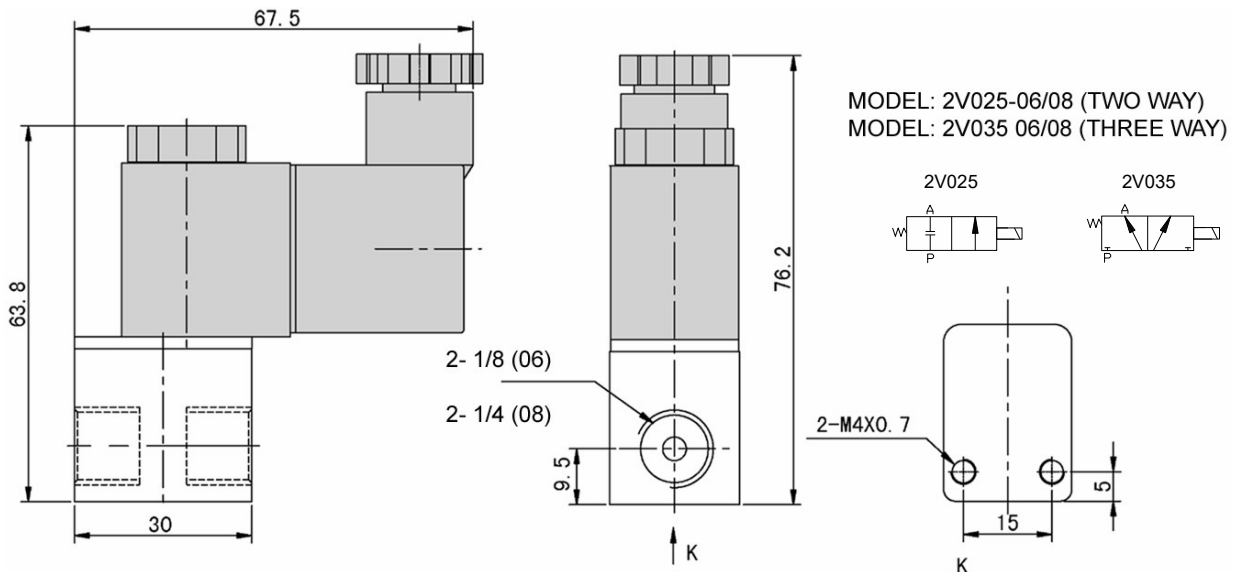
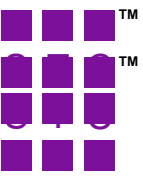

MODEL: 2V1-06B-3F (TWO WAY)
MODEL: 3V1-06B-3F (THREE WAY) Shown as 3 stations

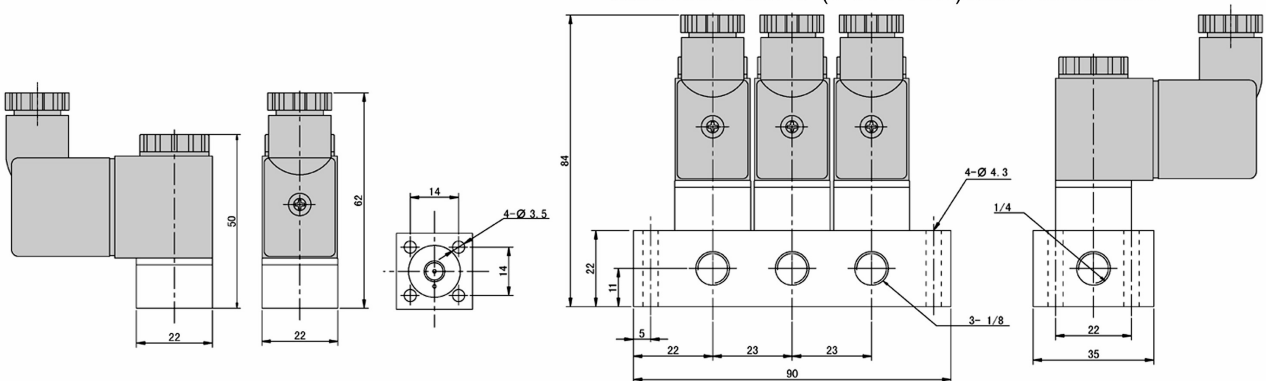

Air Solenoid & Air Pilot Valve Dimensions

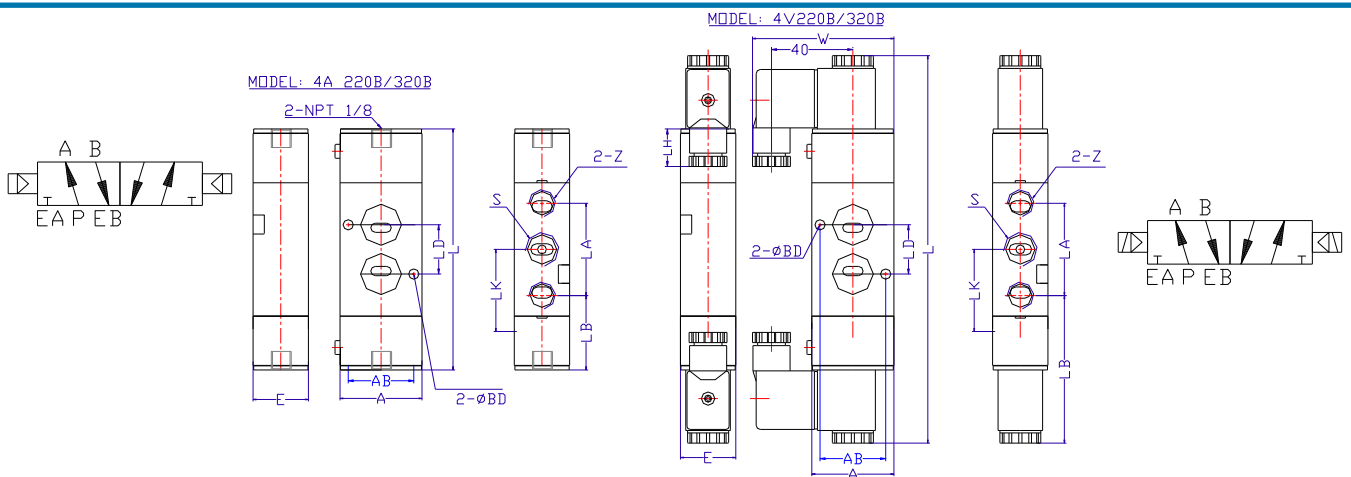
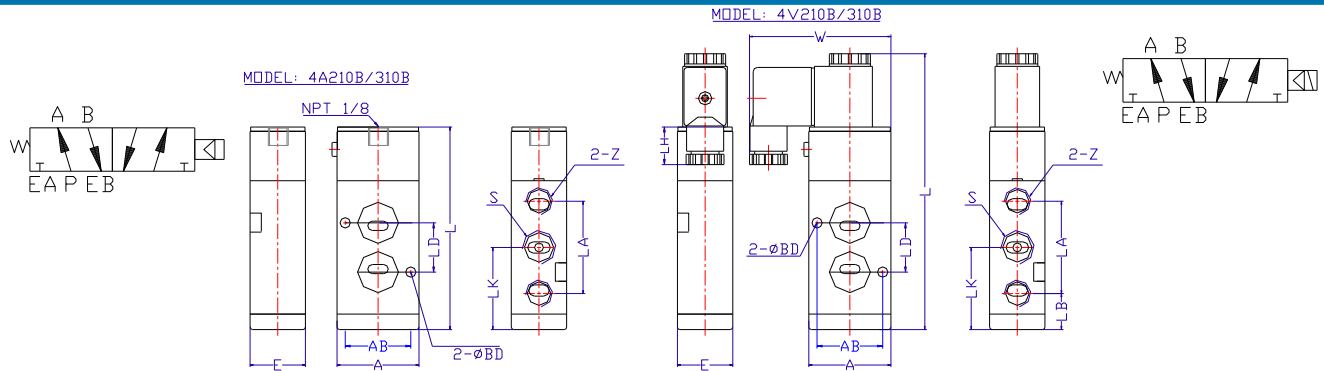
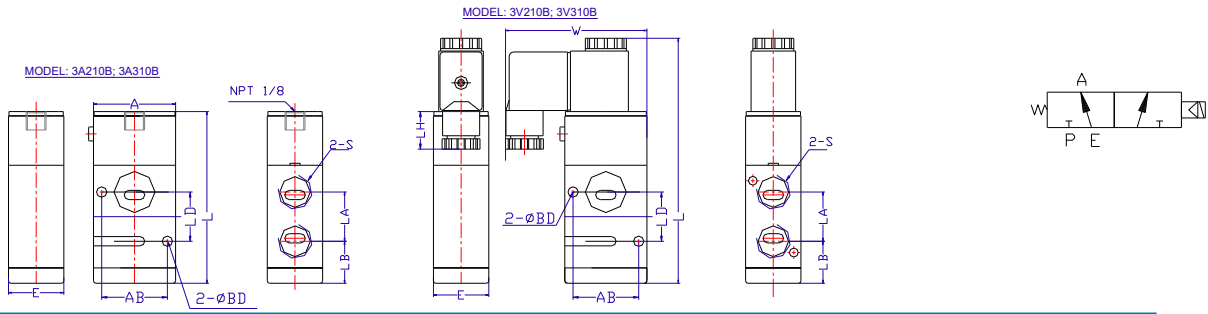

Model	A	E	L	S	W	Z	AB	BD	LA	LB	LD	LH	LK
3A210-1/4B	35	22	77.7	1/4	66.5		29	4.3	18	21			
3A310-1/4B	40	27	80.5	3/8	69		32	5.5	24	20.5			
3A310-3/8B	40	27	80.5	3/8	69		32	5.5	24	20.5			
3V210-1/4B	35	22	111.5	1/4	66.5		29	4.3	18	21		18	
3V310-1/4B	40	27	119.4	1/4	69		32	5.5	24	20.5		18	
3V310-3/8B	40	27	119.4	3/8	69		32	5.5	24	20.5		18	
4A210-1/4B	35	22	77.7	1/4	66.5	1/8	29	4.3	36	13.5	23		31.7
4A310-1/4B	40	27	95.5	1/4	69	1/4	32	5.5	45	17.5	24		40
4A310-3/8B	40	27	95.5	3/8	69	1/4	32	5.5	45	17.5	24		40
4V210-1/4B	35	22	116.5	1/4	66.5	1/8	29	4.3	36	13.5	23	18	32.5
4V310-1/4B	40	27	134.5	1/4	69	1/4	32	5.5	45	17.5	24	18	40
4V310-3/8B	40	27	134.5	3/8	69	1/4	32	5.5	45	17.5	24	18	40
4A220-1/4B	35	22	92	1/4	66.5	1/8	29	4.3	36	28	23		46
4A320-1/4B	40	27	111	1/4	69	1/4	32	5.5	45	33	24		55.5
4A320-3/8B	40	27	111	3/8	69	1/4	32	5.5	45	33	24		55.5
4V220-1/4B	35	22	169.8	1/4	66.5	1/8	29	4.3	36	66.9	23	18	84.9
4V320-1/4B	40	27	188.8	1/4	69	1/4	32	5.5	45	71.9	24	18	94.4
4V320-3/8B	40	27	188.8	3/8	69	1/4	32	5.5	45	71.9	24	18	94.4

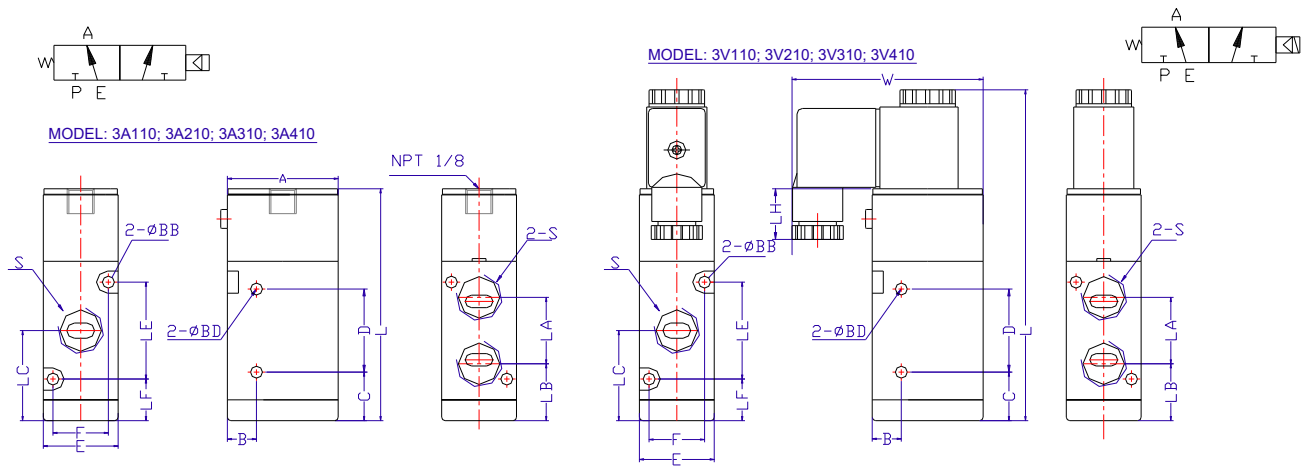

Model No.	A	B	D	E	F	L	S	W	BB	BD	LA	LB	LC	LE	LF	LH
3A110-1/8	27	7.7	21	18.0	13	56.5	1/8	53.5	3.3	3.3	16	14.0	23	19	12.5	
3A210-1/4	35	8.0	25	22.0	17	77.7	1/4	66.5	3.3	4.3	18	21.0	31	33	12.5	
3A310-3/8	40	10.5	30	27.0	20	80.5	3/8	69	4.3	4.3	24	20.5	32.5	35	15	
3A410-1/2	50	13.5	51	34.0	27	96.5	1/2	73.9	4.3	5.5	36	25.5	41.5	44	15.5	
3V110-1/8	27	7.7	21	18.0	13	85.8	1/8	53.5	3.3	3.3	16	14.0	23	19	12.5	10
3V210-1/4	35	8.0	25	22.0	17	111.5	1/4	66.5	3.3	4.3	18	21.0	31	33	12.5	18
3V310-3/8	40	10.5	30	27.0	20	119.4	3/8	69	4.3	4.3	24	20.5	32.5	35	15	18
3V410-1/2	50	13.5	51	34.0	27	137.0	1/2	73.5	4.3	5.5	36	25.5	41.5	44	15.5	18

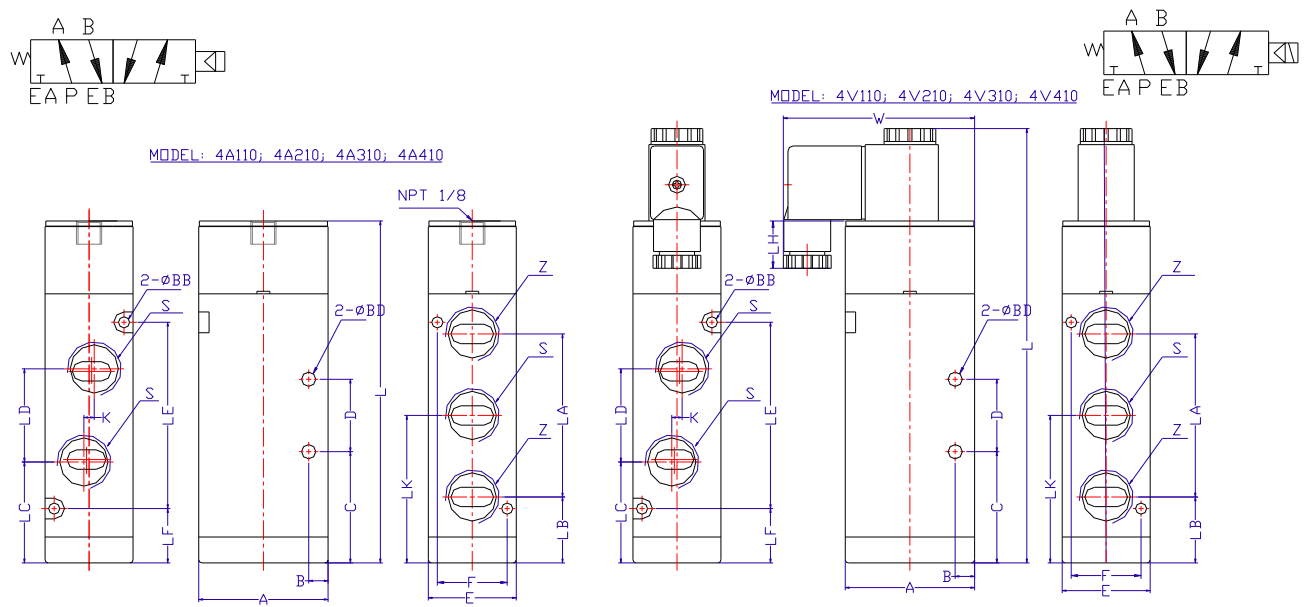

Model No.	A	B	C	D	E	F	K	L	S	W	Z	BB	BD	LA	LB	LC	LD	LE	LF	LH	LK
4A110-1/8	27	4.0	21.0	14	18	13	3	68.7	1/8	53.5	1/8	3.3	3.3	28	14.2	20.2	16	30	13.0		28.2
4A210-1/4	35	7.0	21.5	20	22	17	3	77.7	1/4	66.5	1/8	3.3	4.3	36	13.5	21.0	21	38	12.5		31.7
4A310-3/8	40	6.5	28.0	24	27	20	4	95.5	3/8	69	1/4	4.3	4.3	45	17.5	28.0	24	50	15.0		40.0
4A410-1/2	50	7.5	43.0	28	34	27	4	128	1/2	73.5	1/2	4.3	5.5	63	25.5	39.0	36	72	21.0		57.0
4V110-1/8	27	4.0	21.0	14	18	13	3	98	1/8	53.5	1/8	3.3	3.3	28	14.0	20.0	16	30	13.0	10	28.0
4V210-1/4	35	7.0	21.5	20	22	17	3	116.5	1/4	66.5	1/8	3.3	4.3	36	13.5	21.0	21	38	12.5	18	32.5
4V310-3/8	40	6.5	28.0	24	27	20	4	134.5	3/8	69	1/4	4.3	4.3	45	17.5	28.0	24	50	15.0	18	40.0
4V410-1/2	50	7.5	43.0	28	34	27	4	167.9	1/2	73.5	1/2	4.3	5.5	63	25.5	39.0	36	72	21.0	18	57.0

Air Solenoid & Air Pilot Valve Dimensions Manifold Dimensions

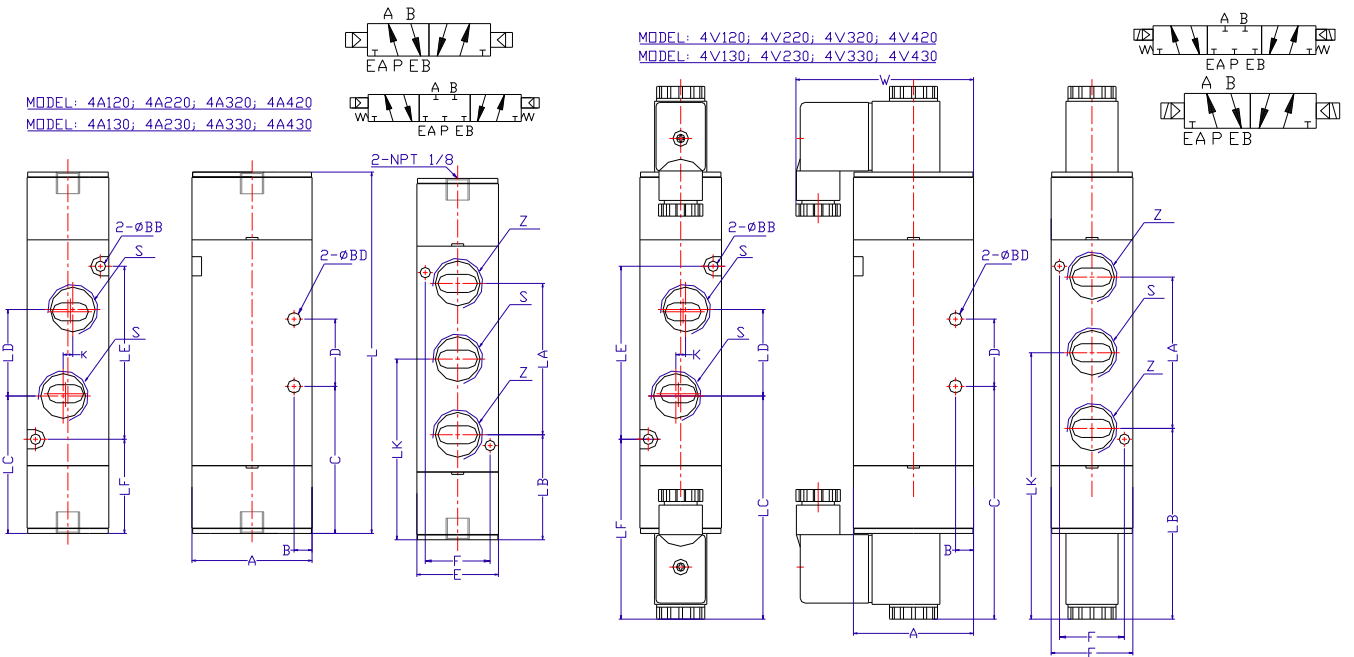

Model No.	A	B	C	D	E	F	K	L	S	W	Z	BB	BD	LA	LB	LC	LD	LE	LF	LH	LK
4A120-1/8	27	4.0	33.5	14	18	13	3	81	1/8	53.5	1/8	3.3	3.3	28	26.5	32.5	16	30	25.5		40.5
4A220-1/4	35	7.0	36.0	20	22	17	3	92	1/4	66.5	1/8	3.3	4.3	36	28.0	37.0	21	38	27.0		46.0
4A320-3/8	40	6.5	43.5	24	27	20	4	111	3/8	69	1/4	4.3	4.3	45	33.0	43.5	24	50	30.5		55.5
4A420-1/2	50	7.5	51.0	28	34	27	4	128	1/2	73.5	1/2	4.3	5.5	63	39.5	71.0	36	72	35.0		71.0
4V120-1/8	27	4.0	62.8	14	18	13	3	139.5	1/8	53.5	1/8	3.3	3.3	28	56.0	52.0	16	30	54.8	10	69.8
4V220-1/4	35	7.0	74.9	20	22	17	3	169.8	1/4	66.5	1/8	3.3	4.3	36	66.9	74.4	21	38	65.9	18	84.9
4V320-3/8	40	6.5	82.4	24	27	20	4	188.8	3/8	69	1/4	4.3	4.3	45	71.9	82.4	24	50	69.4	18	94.4
4V420-1/2	50	7.5	96.9	28	34	27	4	217.5	1/2	73.5	1/2	4.3	5.5	63	79.4	92.9	36	72	74.9	18	110.9
4A130-1/8	27	4.0	33.5	14	18	13	3	96	1/8	53.5	1/8	3.3	3.3	28	26.5	32.5	16	30	25.5		40.5
4A230-1/4	35	7.0	36.0	20	22	17	3	110	1/4	66.5	1/8	3.3	4.3	36	28.0	37.0	21	38	27.0		46.0
4A330-3/8	40	6.5	43.5	24	27	20	4	130	3/8	69	1/4	4.3	4.3	45	33.0	43.5	24	50	30.5		55.5
4A430-1/2	50	7.5	51.0	28	34	27	4	165	1/2	73.5	1/2	4.3	5.5	63	39.5	71.0	36	72	35.0		71.0
4V130-1/8	27	4.0	62.8	14	18	13	3	154.6	1/8	53.5	1/8	3.3	3.3	28	56.0	52.0	16	30	54.8	10	69.8
4V230-1/4	35	7.0	74.9	20	22	17	3	188.8	1/4	66.5	1/8	3.3	4.3	36	66.9	74.4	21	38	65.9	18	84.9
4V330-3/8	40	6.5	82.4	24	27	20	4	207.8	3/8	69	1/4	4.3	4.3	45	71.9	82.4	24	50	69.4	18	94.4
4V430-1/2	50	7.5	96.9	28	34	27	4	242.8	1/2	73.5	1/2	4.3	5.5	63	79.4	92.9	36	72	74.9	18	110.9

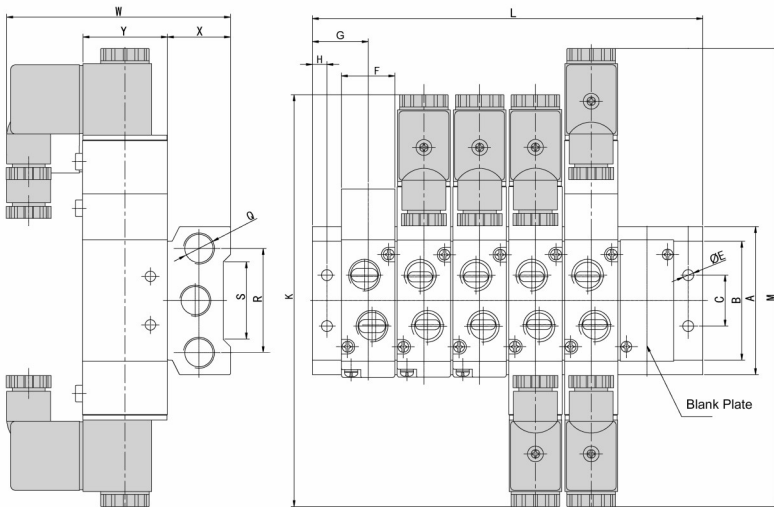

4V100-400M Manifold Dimensions

Model No.	A	B	C	E	F	G	H	K	L
100M	58	44	20	4.2	18.3	19	5	140	(N-1)*19+38
200M	61	51	21	4.3	22.4	23	6	170	(N-1)*23+46
300M	75	65	26	4.5	27.3	27	6	189	(N-1)*28+54
400M	104	95	32	5.5	34.3	31.5	7	222	(N-1)*35+63

Model No.	M	Q	R	S	T	W	X	Y
100M	155	1/4	40	30	M3x.5	78.5	25	27
200M	189	1/4	43	32	M3x.5	92.5	26	35
300M	208	3/8	53	48	M4x.7	99	30	40
400M	243	1/2	68	67	M4x.7	112	38	50



Contents

Manual Air Valve Numbering System.....	G2
Manual Valves Specifications.....	G2
Manual Air Valves List Price.....	G3
Push Buttons Dimensions.....	G4
Hand Lever Dimensions.....	G5 - G6
Foot Pedal Dimensions.....	G7
Quick Exhaust & Control Valve Dimensions.....	G8

Manual Air Valve Numbering System

Ordering Part No. =
(e.g., MOV-03PB)

MOV

03PB

Model		# Way & # Position		Port Size (NPT)		Options
Manual Air Valves	MOV	3 Way 2 Position		1/8	(leave blank)	01 = Turn Select, 02 = Roller, 03 = Button (Momentary) Leave Blank = Plunger (Non-Detented), E = Palm Button (Detented), PB = Palm Push Button (Non-Detented), PPL = Push Button (Non-Detented), PP = Flush Push Button Color Options: G = Green, R = Red
Manual Air Valves	MPV	4 Way 2 Position Toggle	522	1/4	(leave blank)	
Manual Air Valves	MSV	3 Way 2 Position	98322	1/4	(leave blank)	Leave Blank = Plunger (Non-Detented), EB = Emergency Stop Button (Detented), PB = Palm Button (Non-Detented), PP = Flush Push Button (Non-Detented), PPL = Push Button (Non-Detented), R = Roller Lever (Non-Detented), TB = Knob Switch (Detented). Color Options: G = Green, K = Black, R = Red
		4 Way 2 Position	86522			
Hand Lever Valves	TSV	3 Way 2 Position	98322	1/4	(leave blank)	M = Detented, S = Non-Detented (Spring Return)
		4 Way 2 Position	86522			
Hand Lever Valves	4H	4 Way 3 Position (Closed Center)	230C	1/4	(leave blank)	M = Detented, S = Non-Detented (Spring Return), Boot = Rubber Boot, Handle = Black Plastic Handle
		4 Way 3 Position (Exhaust Center)	230E			
		4 Way 3 Position (Pressure Center)	230P			
Pull/Push Valves	3R	3 Way 2 Position	210	1/4	(leave blank)	M = Detented, S = Non-Detented (Spring Return)
	4R	4 Way 2 Position	210			
Hand Valve	HV	4 Way 3 Position	400	1/4	(leave blank)	Leave Blank = Detented
		4 Way 2 Position	410			
Foot Operated Valve	FV	2 Way 2 Position	220	1/4	(leave blank)	Leave Blank = Detented, FT = Rubber Foot Pad for Valve
		3 Way 2 Position	320			
		4 Way 2 Position	420			
	4F	4 Way 2 Position	210	1/4	(leave blank)	Leave Blank = Detented, FT = Rubber Foot, L = Detented (with Lock), G = Guard

Specifications

Model No.	FV Series	HV Series	MOV Series	MPV Series	MSV Series	TSV Series	3R-4R Series	4F Series	4H Series
Description	Foot Valves	Hand Valves	Hand Valves	Toggle Valves	Hand Valves	Lever Valves	Pull/Push Valves	Foot Valves	Lever Valves
Cv	0.89	1.68	0.67	1.0	0.89	1.0	0.89	1.68	0.89
Operating Pressure	0 to 116 PSI								
Operating Temperature	14 to 140°F (-10 to 60°C)								
Action	Direct Acting								
Working Medium	40 micron filtered air or inert gas								
Body Material	Aluminum (Anodized)								
Seal Material	NBR								
Lubrication	Not Required								

Specifications

Model No.	ASC Series	AS Series	QE Series	ST Series
Description	Flow Control Valves	Flow Control Valves	Quick Exhaust Valves	Shuttle Valves
Orifice (mm)	1/8" = 4.6; 1/4" = 6.0; 3/8" = 6.2; 1/2" = 9.6; 3/4" = 9.8			
Operating Pressure	0 to 140 PSI	7 to 145PSI	0 to 145PSI	
Operating Temperature	14 to 140°F (-10 to 60°C)			
Working Medium	40 micron filtered air or inert gas			
Body Material	Aluminum (Anodized)			
Seal Material	NBR			
Lubrication	Not Required			

1/4" NPT 4 Way 5 Port 2 Position Air Valves											
Model No.	MSV-86522TB	MSV-86522EB	MSV-86522PB	MSV-86522PP	MSV-86522PPL	MSV-86522R	TSV86522M	TSV86522S	4R210-1/4M	4R210-1/4S	
Price	\$41.95	\$41.95	\$41.95	\$41.95	\$41.95	\$41.95	\$44.19	\$44.19	\$29.68	\$29.68	
Description	Two Position Detented Switch Cv 0.89	Emergency Stop Detented Cv 0.89	Palm Button Momentary Cv 0.89	Push Button Momentary Cv 0.89	High Push Button Momentary Cv 0.89	Roller Lever Cv 0.89	Lever M = Detented S = Non-detented	Lever M = Detented S = Non-detented	Pull/Push M = Detented S = Non-detented	Pull/Push M = Detented S = Non-detented	
1/4" NPT 4 Way 5 Port 2 Position Air Valves		1/4" NPT 4 Way 5 Port 3 Position Air Valves					1/4" NPT 3 Way 3 Port 2 Position Air Valves				
Model No.	MPV522	Model No.	4H230C-M 4H230C-S	4H230E-M 4H230E-S	4H230P-M 4H230P-S	4H230S-M 4H230S-S	Model No.	TSV98322M TSV98322S	TSV98322M TSV98322S	3R210-1/4M 3R210-1/4S	3R210-1/4S
Price	\$59.57	Price	\$91.54	\$91.54	\$91.54	\$91.54	Price	\$41.95	\$41.95	\$28.93	\$28.93
Description	Toggle Switch Cv 0.89	Description	3 Position, 4 Way Closed Center M = Detented S = Non-detented	3 Position, 4 Way Exhaust Center M = Detented S = Non-detented	3 Position, 4 Way Pressure Center M = Detented S = Non-detented	3 Position, 4 Way Pressure Center M = Detented S = Non-detented	Description	Lever M = Detented S = Non-detented	Lever M = Detented S = Non-detented	Pull/Push M = Detented S = Non-detented	Pull/Push M = Detented S = Non-detented
1/4" NPT 3 Way 3 Port 2 Position Air Valves							1/8" NPT 3 Way 2 Port 2 Position Air Valves				
Model No.	MSV-98322TB	MSV-98322EB	MSV-98322PB	MSV98322PP	MSV-98322R	MSV-98322R	Model No.	MOV-01	MOV-02	MOV-01	MOV-02
Price	\$39.80	\$39.80	\$41.15	\$39.80	\$39.80	\$39.80	Price	\$25.33	\$25.33	\$25.33	\$25.33
Description	Two Position Switch Cv 0.89	Emergency Stop Detented Cv 0.89	Palm Button Momentary Cv 0.89	Push Button Momentary Cv 0.89	Roller Lever Momentary Cv 0.89	Roller Lever Momentary Cv 0.89	Description	Two Position Switch Cv 0.67	Roller Lever Normally Closed Cv 0.67	Two Position Switch Cv 0.67	Roller Lever Normally Closed Cv 0.67
1/8" NPT 3 Way 2 Port 2 Position Air Valves							1/4" NPT Air Valves				
Model No.	MOV-03EB	MOV-03PL	MOV-03PP	MOV-03PB	MOV-03PB	MOV-03PB	Model No.	HV 410	HV 400/420	HV 410	HV 400/420
Price	\$25.33	\$25.33	\$25.33	\$25.33	\$25.33	\$25.33	Price	\$45.58	\$45.58	\$45.58	\$45.58
Description	Emergency Stop Momentary Cv 0.67	Push Button Momentary Cv 0.67	Flush Push Button Momentary Cv 0.67	(Green) Palm Button Momentary Cv 0.67	(Green) Palm Button Momentary Cv 0.67	(Green) Palm Button Momentary Cv 0.67	Description	2 Position 4 Way Valve Cv 1.68	3 Position 4 Way Valve Closed Center Cv 1.68	2 Position 4 Way Valve Cv 1.68	3 Position 4 Way Valve Closed Center Cv 1.68
1/4" NPT Air Valves											
Model No.	FV220-1/4	FV320-1/4	FV420-1/4	4F210	4F210L	4F210L	4F210G	4F210GL	4F210G	4F210GL	4F210GL
Price	\$48.47	\$48.47	\$51.37	\$58.60	\$75.20	\$75.20	\$91.85	\$117.92	\$91.85	\$117.92	\$117.92
Description	2 Way Momentary Foot Valve	3 Way Momentary Foot Valve	4 Way Momentary Foot Valve	4 Way Momentary Foot Valve	4 Way Momentary Foot Valve	4 Way Detented Foot Valve	4 Way Shielded Momentary Foot Valve	4 Way Shielded Detented Foot Valve	4 Way Shielded Momentary Foot Valve	4 Way Shielded Detented Foot Valve	4 Way Shielded Detented Foot Valve

Model	Quick Exhaust		Shuttle Valve		In-line Flow Control		In-line Flow Control		Speed Control Muffler		Muffler		Union Valve	
	QE	ST	ASC	AS	BESL	BESL	BESL	BESL	BESL	BESL	UV	UV	UV	UV
Port	Part No.	Unit Price	Part No.	Unit Price	Part No.	Unit Price	Part No.	Unit Price	Part No.	Unit Price	Part No.	Unit Price	Part No.	Unit Price
10-32											BESL 10-32	\$1.40		
1/8	QE N1/8	\$19.98	ST N1/8	\$19.98	ASC N1/8	\$18.81	AS N1/8	\$12.08	BESL N1/8	\$5.10	BESL N1/8	\$1.40	UV 6-6	\$16.92
1/4	QE N1/4	\$22.57	ST N1/4	\$22.57	ASC N1/4	\$18.81	AS N1/4	\$12.08	BESL N1/4	\$7.24	BESL N1/4	\$2.71	UV 1/4-1/4	\$16.92
3/8	QE N3/8	\$22.57	ST N3/8	\$22.57	ASC N3/8	\$21.71	AS N3/8	\$14.47	BESL N3/8	\$11.11	BESL N3/8	\$4.10		
1/2	QE N1/2	\$25.70	ST N1/2	\$36.84	ASC N1/2	\$26.04	AS N1/2	\$22.65	BESL N1/2	\$15.27	BESL N1/2	\$6.29		

Push Button Dimensions

MODEL: MSV86522-XX

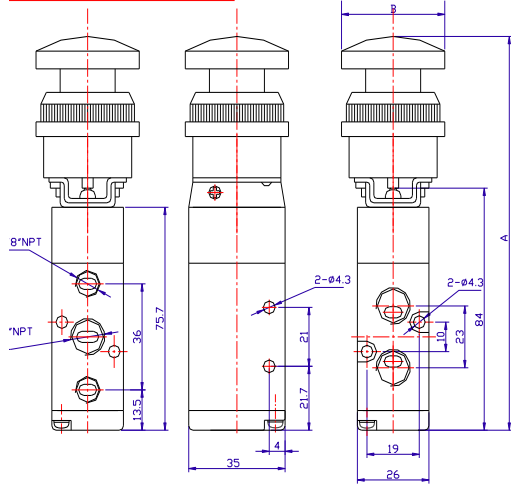

MODEL: MSV98322-XX

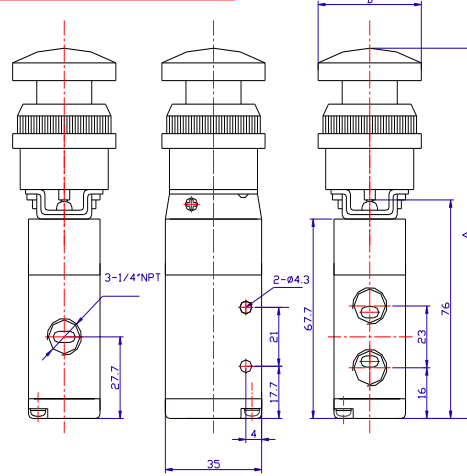

MODEL: MDV-XX

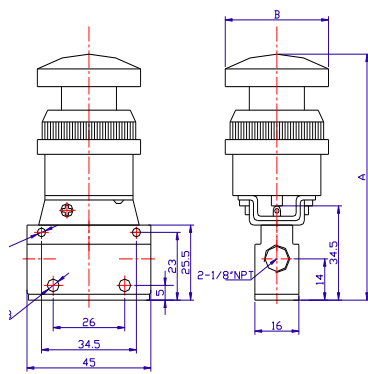

BUTTON STYLE

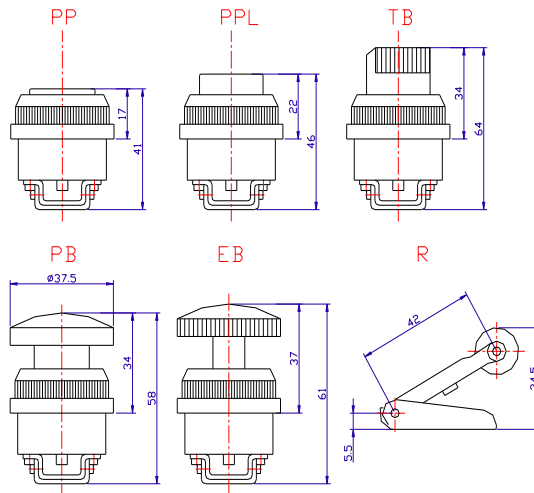

PANEL MOUNT HOLE SIZE 1 3/16" (30 MM)

Unit in (mm)

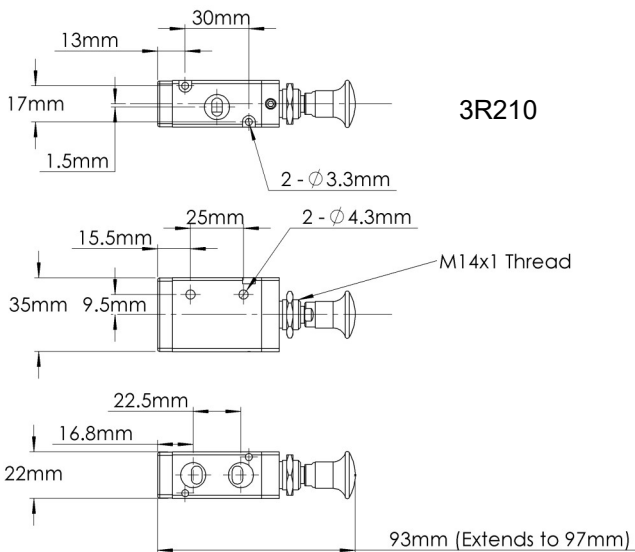

*NOTE: Available as either Detented (-M) or Non-Detented (-S)

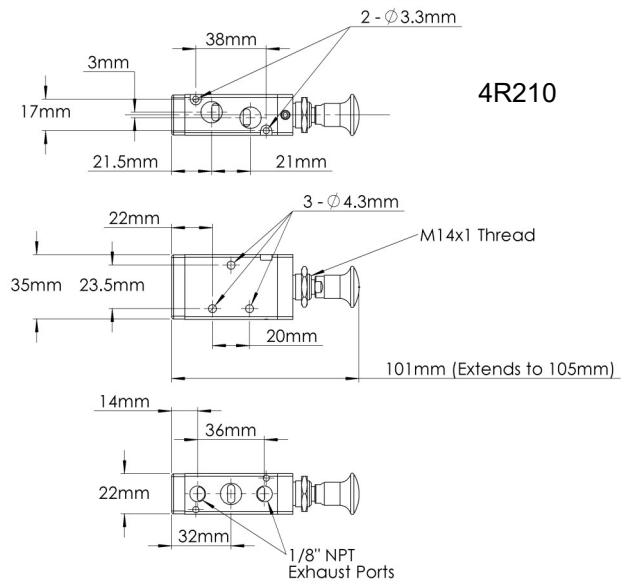

*NOTE: Available as either Detented (-M) or Non-Detented (-S)

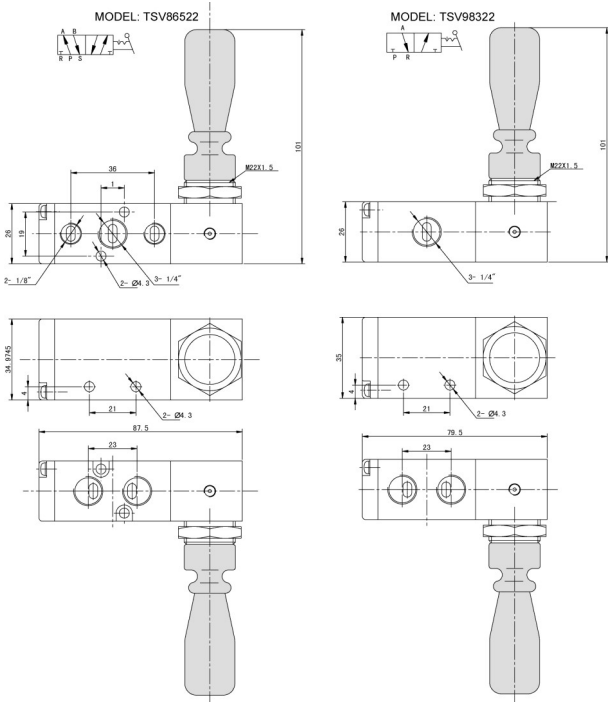

MPV

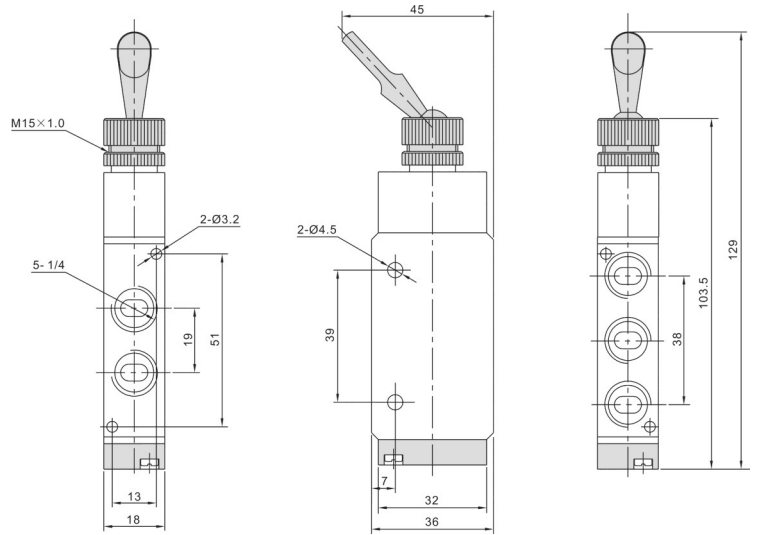

MODEL: 4H230C-1/4

5 PORT 3 POSITION MOMENTARY HAND LEVER VALVE

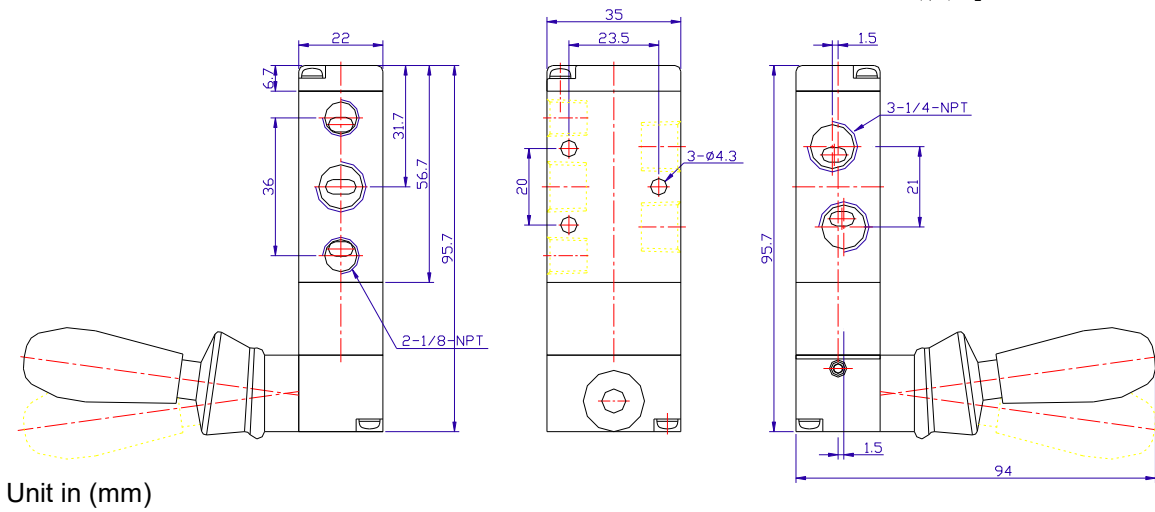
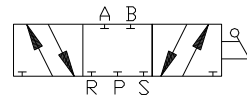

Unit in (mm)

Hand Lever Dimensions

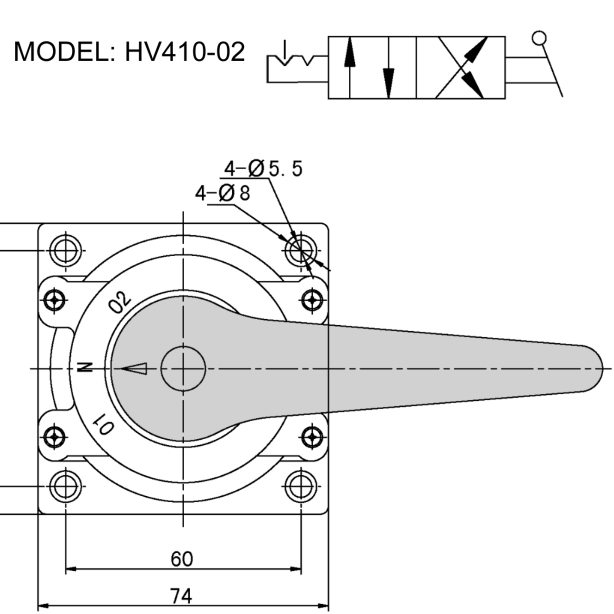
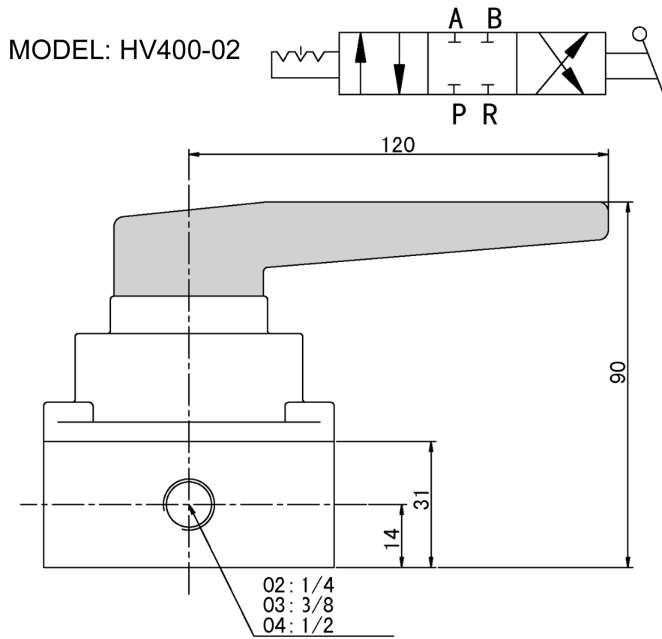

MODEL: FV320-420

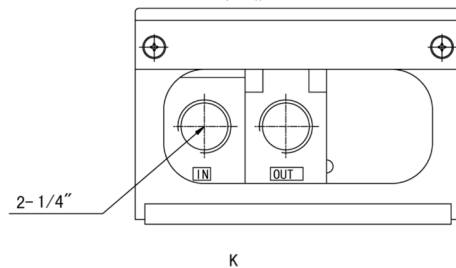
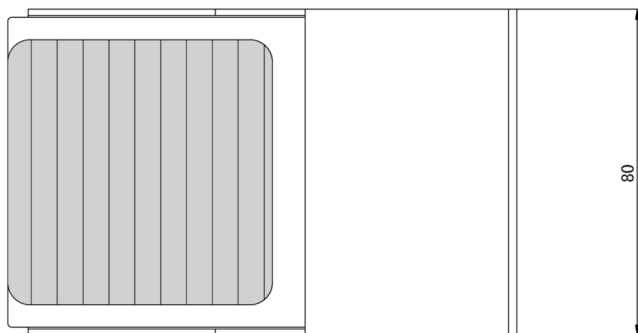
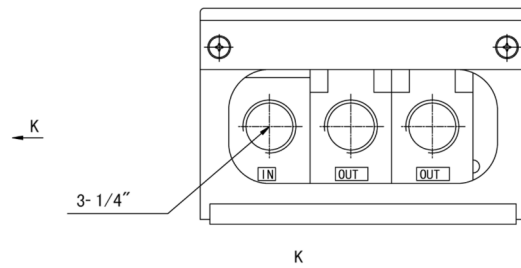
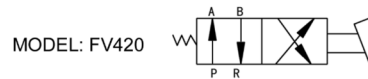
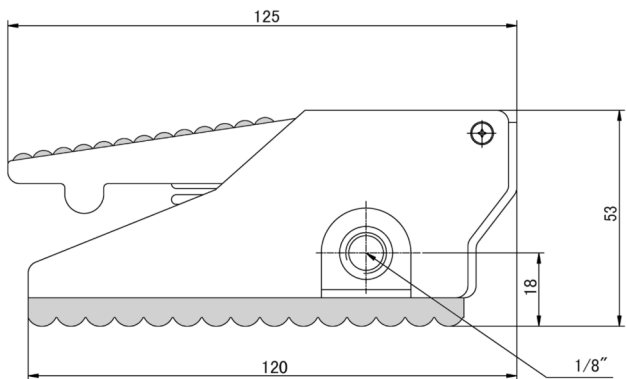

Unit in (mm)

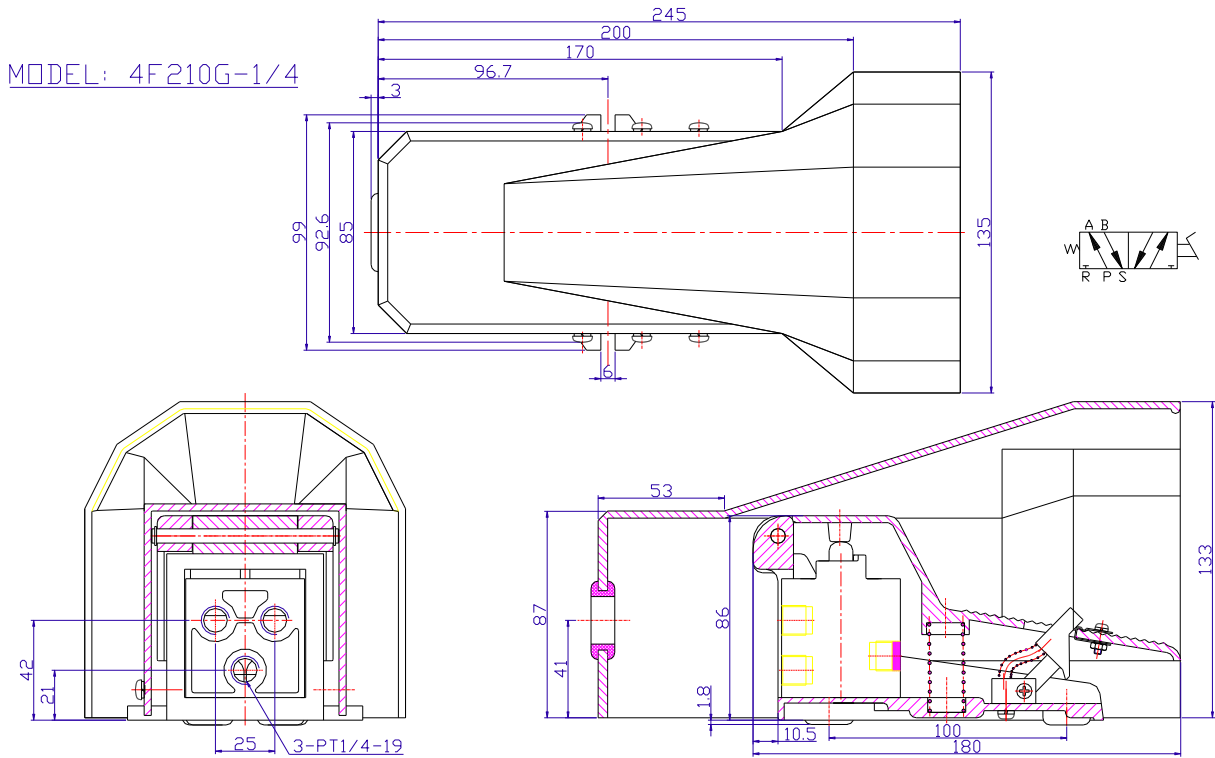
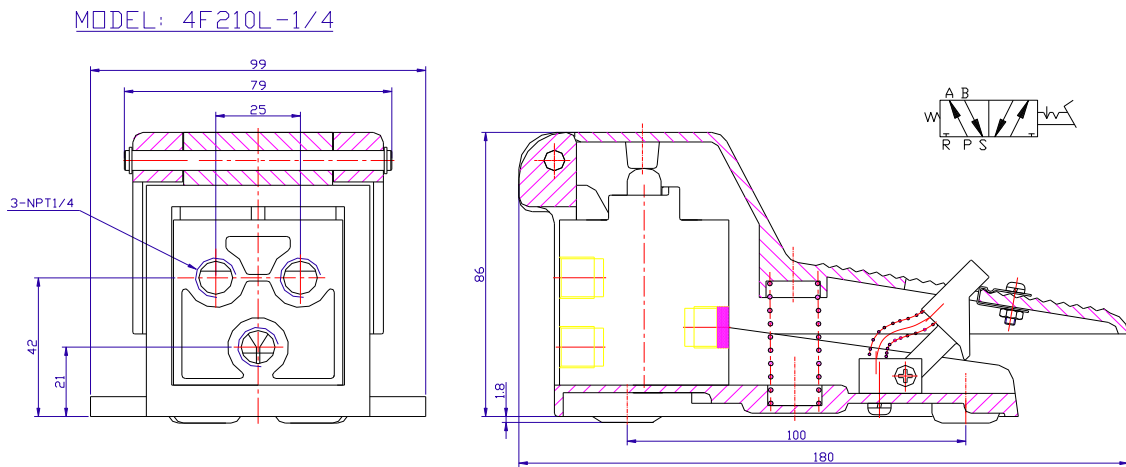
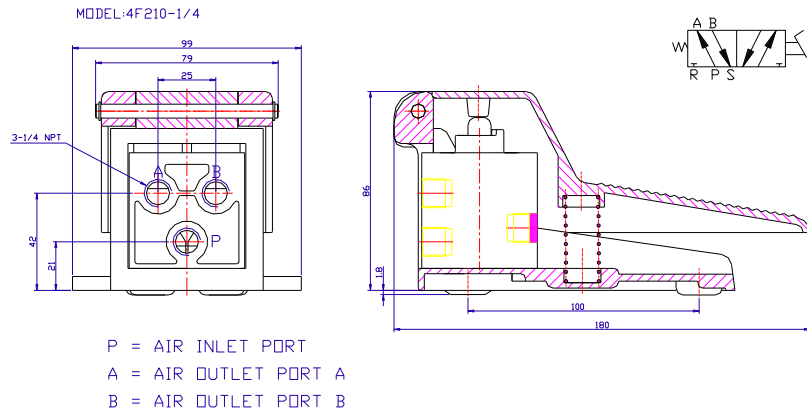

Unit in (mm)

Quick Exhaust Valve

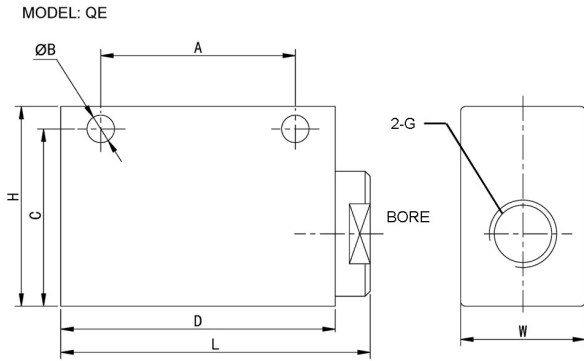
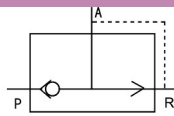

Quick Exhaust Valve (mm)										
Model No.	Bore (NPT)	G (NPT)	L	W	H	A	B	C	D	Cv
QE-01	1/4	1/8	46	20	32	30	4.3	27.0	40	1.0
QE-02	3/8	1/4	62	25	40	39	5.6	33.5	55	1.3
QE-03	1/2	3/8	62	25	40	39	5.6	33.5	55	1.4
QE-04	3/4	1/2	98	38	64	60	8.5	51.0	90	4.0
QE-06	1	3/4	98	38	64	60	8.5	51.0	90	4.1

Shuttle Valve

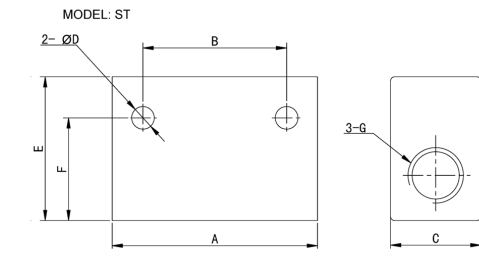
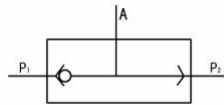

Shuttle Valve (mm)								
Model No.	A	B	C	D	E	F	G (NPT)	Cv
ST-01	40	24	16	4.5	25	21	1/8	0.35
ST-02	50	35	22	5.5	35	25	1/4	1.0
ST-03	75	48	30	7.0	50	42	3/8	2.0
ST-04	75	48	30	7.0	50	42	1/2	3.5
ST-06	110	72	40	7.0	70	58	3/4	6.0
ST-08	110	72	40	7.0	70	58	1	100.

ASC N1/8

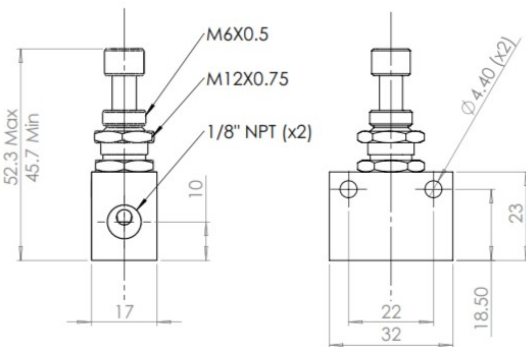

ASC N1/4

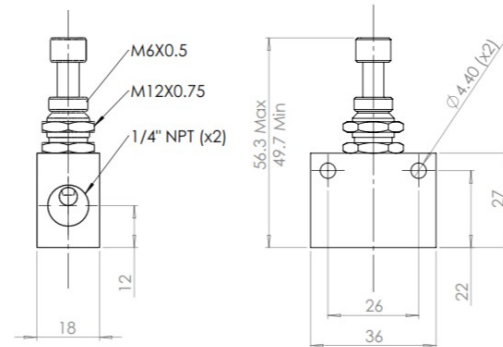

ASC N3/8

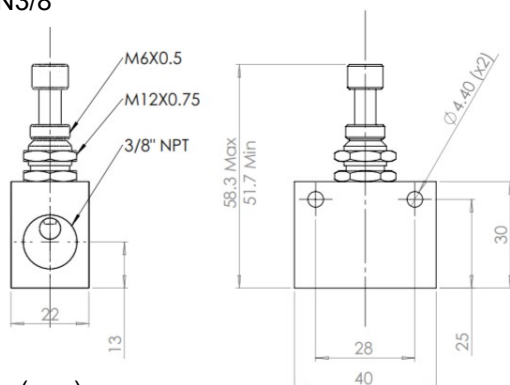

ASC N1/2

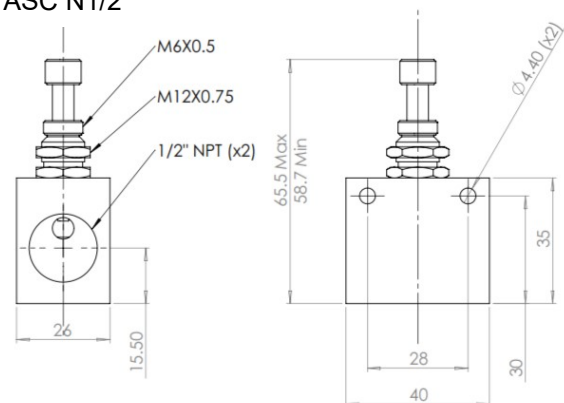

Unit in (mm)

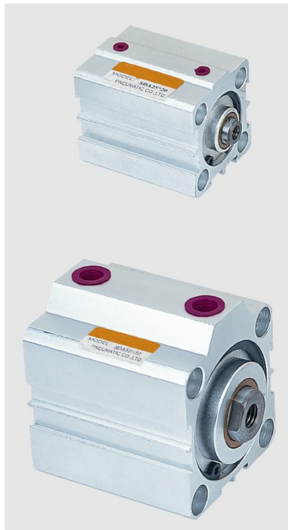
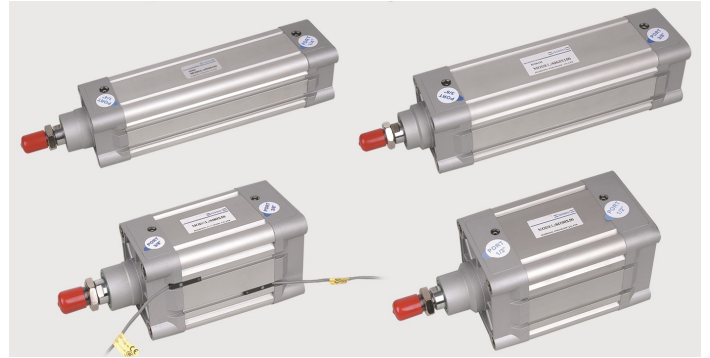
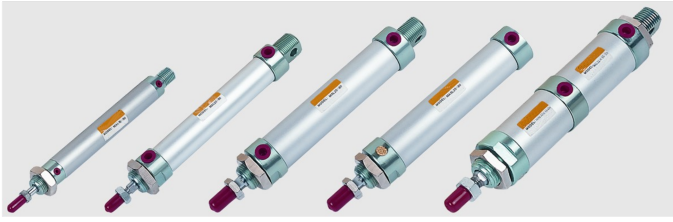

Fine Quality

Excellent Prices

Precision Engineered

Advanced Design

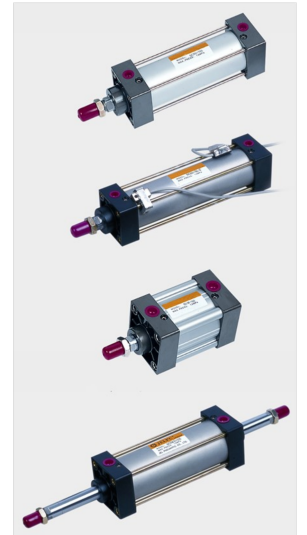

Contents

Air Cylinder Numbering System.....	H2
Air Cylinder Technical Data.....	H3
MA & MAL Series Stainless Steel Round Cylinder Dimensions.....	H4
MA & MAL Series Mounting Options Dimensions.....	H5
SC & SU Series Cylinder Dimensions.....	H6
SC & SU Series Mounting Options Dimensions.....	H7
SDA & SSA Series Compact Cylinder Dimensions.....	H8

Ordering Part No. =
(e.g., SSA 32X20)



Model			Bore (mm)	Stroke (mm)	Magnet (Optional)	Options
MA Series Stainless Steel Round Cylinder	Double Acting	MA	12 16 20	25-500	(Leave Blank) = without Magnet S = Magnet for Hall Sensor	Mounting Options: (Leave Blank) = Standard Front Nose Mount and Back Pivot Mount LB = Front & Back Mount FA = Front Mounting Flange FB = Back Mounting Flange SDB = Back Clevis Bracket with Pin I = Rod Pivot with Pin
	Single Acting (Spring Return)	MSA	25 32 40			
MAL Series Aluminum Round Cylinder	Double Acting	MAL	16 20 25	25-500	(Leave Blank) = without Magnet S = Magnet for Hall Sensor	Mounting Options: (Leave Blank) = Standard Front Nose Mount and Back Pivot Mount LB = Front & Back Mount FA = Front Mounting Flange FB = Back Mounting Flange SDB = Back Clevis Bracket with Pin I = Rod Pivot with Pin
	Single Acting (Spring Return)	MALS	32 40			
SC Series Tie-Rod Cylinder	Double Acting	SC	32 40 50 63 80 100 125	25-1000	(Leave Blank) = without Magnet S = Magnet for Hall Sensor	Mounting Options: (Leave Blank) = Standard Mount LB = Foot Mount FA = Front Mounting Flange FB = Back Mounting Flange CA = Pivot Bracket with Pin CB = Clevis Bracket with Pin TCM = Swinging Type Attaching Foot Seat Y/I = Rod Clevis or Pivot with Pin
SU Series Enclosed Tie-Rod Cylinder	Double Acting	SU	160 200 250 320			
SDA Series Compact Round Cylinder	Double Acting	SDA	12 16 20 25 32 40	5-130	(Leave Blank) = without Magnet S = Magnet for Hall Sensor	Thread Type Options: (Leave Blank) = Shaft with Female Thread
	Single Acting	SSA	50 63 80 100			

Part No.	Description	Specifications
AL-03R-MA MAL	Reed Switch for MA or MAL cylinder	Reed Switch 5-240 V (DC/AC) 100 mA 10W (with 39" Lead Wires)
AL-11R-SDA	Reed Switch for SDA cylinder	
AL-21R-SC SU	Reed Switch for SC or SU cylinder	
AL-30R-SI	Reed Switch for SI cylinder	

MA/MAL Internal Components

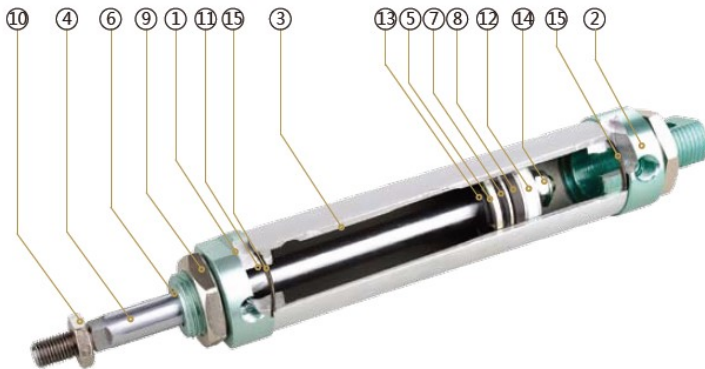

Item	Name	MA Series Cylinder Material	MAL Series Cylinder Material	Quantity
1	Front Cover	Hard Anodized Aluminum	Hard Anodized Aluminum	1
2	Back Cover	Hard Anodized Aluminum	Hard Anodized Aluminum	1
3	Barrel	Stainless Steel	Hard Anodized Aluminum	1
4	Piston Rod	Chromed Carbon Steel	Chromed Carbon Steel	1
5	Piston	Aluminum	Aluminum	1
6	Piston Rod Seal	NBR	NBR	1
7	Piston Seal	NBR	NBR	1
8	Magnet	Ferric Magnet	Ferric Magnet	1
9	Front & Rear Cover	Carbon Steel	Carbon Steel	1
10	Piston Rod Screw	Carbon Steel	Carbon Steel	1
11	Bearing	Non-Lube Bearing	Non-Lube Bearing	1
12	Anti-Friction Ring	PTFE	PTFE	1
13	Cushing Gasket	NBR	NBR	2
14	Fixing Screw	Carbon Steel	Carbon Steel	1
15	Cover Seal	NBR	NBR	2

SC/SU Internal Components

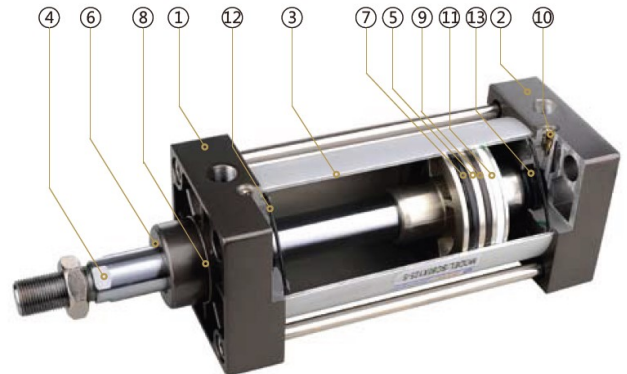

Item	Name	Material	Quantity
1	Front Cover	Polymer Coated Aluminum	1
2	Back Cover	Polymer Coated Aluminum	1
3	Cylinder Barrel	Anodized Aluminum	1
4	Piston Rod	Chromed Carbon Steel	1
5	Piston	Aluminum	1
6	Piston Rod Seal	NBR	1
7	Piston Seal	NBR	2
8	Bearing	Non-Lube Bearing	1
9	Magnet	Ferric Magnet	1
10	Cushion Screw	Brass	2
11	Anti-Friction Ring	PTFE	1
12	End Cap Seal	NBR	2
13	Cushion Seal	NBR	2

MA/MAL Round Cylinder Technical Data						
Bore (mm)	12	16	20	25	32	40
Motion Pattern	Double Action/Single Action					
Working Medium	Air					
Fixed Type	Basic Type/LB Type/FA Type/SDB Type					
Operating Pressure	Double Acting: 14 to 130 PSI (1.0~9.0 bar); Single Acting: 29 to 130 PSI (2.0~9.0 bar)					
Ensured Pressure Resistance	195 PSI (13.5bar)					
Operating Temperature	0 to 70 °C					
Operating Speed	50 ~ 800mm/s					
Buffer Type	Spacer Buffer		Adjustable Buffer (MA and MAL only have spacer buffer)			
Port Size	M5x0.8			G 1/8		G 1/4

SU/SC Cylinder Technical Data									
Bore (mm)	32	40	50	63	80	100	125	160	200
Motion Pattern	Double Action								
Working Medium	Air								
Fixed Type	Basic / LB / FA / CA / CB / TC / TC-M Type								
Operating Pressure	14 to 130 PSI (1.0~9.0bar)								
Ensured Pressure Resistance	195 PSI (13.5bar)								
Operating Temperature	0 to 70 °C								
Operating Speed	50 ~ 800mm/s								
Cushioning Length	20			26			45		
Port Size	G 1/8"	G 1/4"	G 3/8"			G 1/2"		G 3/4"	

MA & MAL Series Stainless Steel Round Cylinder Dimensions

MA

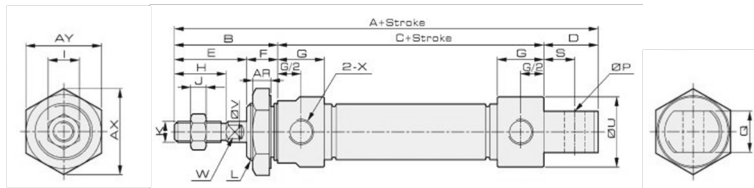

Model: MA													
Bore	A	A1	B	C	D	D1	E	F	G	H	I	J	K
16	114	98	38	60	16	12	22	16	12	16	10	5	M6 X 1
20	137	116	40	76	21	12	28	12	18	20	12	6	M8 X 1.25
25	141	120	44	76	21	14	30	14	16	22	17	6	M10 X 1.25
32	147	120	44	76	27	14	30	14	16	22	17	6	M10 X 1.25
40	150	123	46	77	27	14	32	14	16.7	24	19	7	M12 X 1.25
Bore	L	P	Q	S	U	V	W	X	AR	AX	AY		
16	M16 X 1.5	6	12	9	21	6	5	M5 x 0.8	6	27.8	24		
20	M22 X 1.5	8	16	12	27	8	6	G1/8	7	33.5	29		
25	M22 X 1.5	8	16	12	30	10	8	G1/8	7	33.5	29		
32	M24 X 2.0	10	16	15	35	12	10	G1/8	8	37	32		
40	M30 X 2.0	12	20	15	42	16	14	G1/4	9	46	40		

MSA

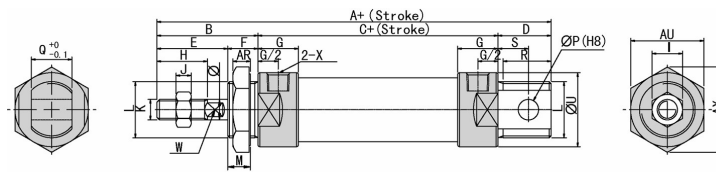

Symbol	A			A1			B	C			D	D1	E	F	G	H	I	J	K	L	P	Q	S	U	V	W	X	AR	AX	AY
	0-50	51-100	100-150	0-50	51-100	100-150		0-50	51-100	100-150																				
12	138	-	-	122	-	-	38	84	-	-	16	12	22	16	12	16	10	5	M6 x 1	M16 x 1.5	6	12	9.5	21	6	5	M5 x 0.8	6	27.8	24
16	139	164	-	123	148	-	38	85	110	-	16	12	22	16	12	16	10	5	M6 x 1	M16 x 1.5	6	12	9	21	6	5	M5 x 0.8	6	27.8	24
20	162	187	212	141	166	191	40	101	126	151	21	12	28	12	18	20	12	6	M8 x 1.25	M22 x 1.5	8	16	12	27	8	6	G1/8	7	33.5	29
25	166	191	216	145	170	195	44	101	126	151	21	14	30	14	16	22	17	6	M10 x 1.25	M22 x 1.5	8	16	12	30	10	8	G1/8	7	33.5	29
32	172	197	222	145	170	195	44	101	126	151	27	14	30	14	16	22	17	6	M10 x 1.25	M24 x 2.0	10	16	15	35	12	10	G1/8	8	37	32
40	175	200	225	148	173	198	46	102	127	152	27	14	32	14	16.7	24	19	7	M12 x 1.25	M30 x 2.0	12	20	15	42	16	14	G1/4	9	46	40

MAL

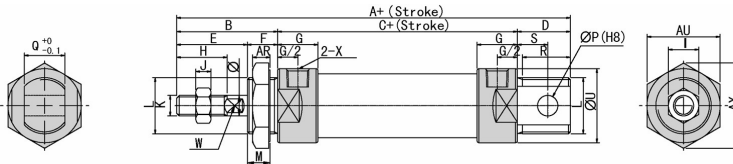

Bore	A	A1	B	C	D	D1	E	F	G	G1	H	I	J	K	L	P	Q	S	U	V	W	X	AR	AX	AY	Y
16	105	90	38	52	15	12	24	14	11	6.5	16	10	5	M6 x 1	M16 x 1.5	6	12	6	21	6	5	M5 x 0.8	6	27.8	24	6
20	131	110	40	70	21	12	28	12	16	12	20	12	6	M8 x 1.25	M22 x 1.5	8	16	12	27	8	6	G1/8	7	33.5	29	9
25	135	114	44	70	21	14	30	14	16	11	22	17	6	M10 x 1.25	M22 x 1.5	8	16	12	32	10	8	G1/8	7	33.5	29	9
32	141	114	44	70	27	14	30	14	16	11.5	22	17	6	M10 x 1.25	M24 x 2.0	10	16	15	39.5	12	10	G1/8	9	37	32	11.5
40	165	138	46	92	27	14	32	14	22	15	24	19	7	M12 x 1.25	M30 x 2.0	12	20	15	47	16	14	G1/4	9	46	40	14

MALS

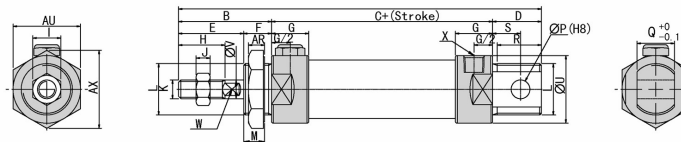

Symbol	A			A1			B	C			D	D1	E	F	G	H	I	J	K	L	P	Q	S	U	V	W	X	AR	AX	AY
	0-50	51-100	101-150	0-50	51-100	101-150		0-50	51-100	101-150																				
16	130	155	-	115	140	-	38	77	102	-	15	12	24	14	11	16	10	5	M6 x 1	M16 x 1.5	6	12	6	21	6	5	M5 x 0.8	6	27.8	24
20	156	181	206	135	160	185	40	95	120	145	21	12	28	12	16	20	12	6	M8 x 1.25	M22 x 1.5	8	16	12	27	8	6	G1/8	7	33.5	29
25	160	185	210	139	164	189	44	95	120	145	21	14	30	14	16	22	17	6	M10 x 1.25	M22 x 1.5	8	16	12	32	10	8	G1/8	7	33.5	29
32	166	191	216	139	164	189	44	95	120	145	27	14	30	14	16	22	17	6	M10 x 1.25	M24 x 2.0	10	16	15	39.5	12	10	G1/8	8	37	32
40	190	215	240	163	188	213	46	117	142	167	27	14	32	14	22	24	19	7	M12 x 1.25	M30 x 2.0	12	20	15	47	16	14	G1/4	9	46	40

FA/FB
(Front or Rear Flange)

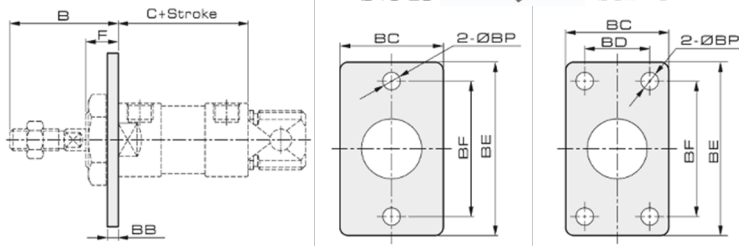

FA/FB (Front/Back Mounting Flange)									
Symbol	C		C (MSA Series)			C (MSAL Series)			F
	MA Series	MAL Series	0-50	50-100	100-150	0-50	50-100	100-150	
16	60	52	85	110	-	77	102	-	
20	76	70	101	126	151	95	120	145	
25	76	70	101	126	151	95	120	145	
32	76	70	101	126	151	95	120	145	
40	77	92	102	127	152	117	142	167	
Symbol/Bore	B	BB	BC	BD	BE	BF	BP	F	
16	38	3	26	-	52	40	5.5	16	
20	40	4	38	-	64	50	6.5	12	
25	44	4	38	-	64	50	6.5	14	
32	44	4	47	33	72	58	6.5	14	
40	46	4	50	36	84	70	6.5	14	

LB
(Foot Mount)

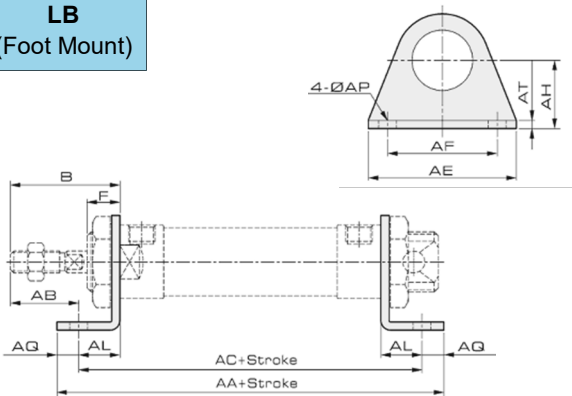

LB (Front/Back Mounting)													
Symbol	AA		AA (MSA Series)			AA (MSAL Series)			B	AB	AE	AF	AH
	MA Series	MAL Series	0-50	50-100	100-150	0-50	50-100	100-150					
16	98	90	123	148	-	115	140	-	38	25	44	32	20
20	122	116	147	172	197	141	166	191	40	25	54	40	25
25	122	116	147	172	197	141	166	191	44	29	54	40	25
32	142	136	167	192	217	161	186	211	44	19	59	45	32
40	143	158	168	193	218	183	208	233	46	21	64	50	36
Symbol	AC		AC (MSA Series)			AC (MSAL Series)			AL	AP	AQ	AT	F
Bore/Stroke	MA Series	MAL Series	0-50	50-100	100-150	0-50	50-100	100-150					
16	86	78	111	136	-	103	128	-	13	5.5	6	3	16
20	106	100	131	156	181	125	150	175	15	6.5	8	3	12
25	106	100	131	156	181	125	150	175	15	6.5	8	3	14
32	126	120	151	176	201	145	170	195	25	6.5	8	4	14
40	127	142	152	177	202	167	192	217	25	6.5	8	4	14

SDB
(Back Clevis Bracket with Pin)

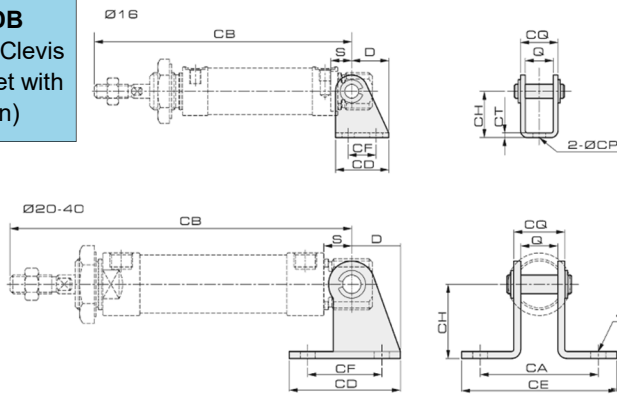

SDB (Back Hinge)										
Symbol	CB		CB (MSA Series)			CB (MSAL Series)			D	
	Bore/Stroke	MA Series	MAL Series	0-50	50-100	100-150	0-50	50-100		100-150
16	107	96	132	157	-	121	146	-	16	
20	128	122	153	178	203	147	172	197	21	
25	132	126	157	182	207	151	176	201	21	
32	135	129	160	185	210	154	179	204	27	
40	138	153	163	188	213	178	203	228	27	
Symbol/Bore	S	Q	CA	CD	CE	CF	CH	CT	CP	CQ
16	9	12	-	23	-	12	20	2	5.5	16
20	12	16	51	48	67	32	32	3	6.5	22
25	12	16	51	48	67	32	32	3	6.5	22
32	15	16	51	52	67	36	36	4	6.5	24
40	15	20	55	56	71	40	40	4	6.5	28

I
(Rod Pivot with Pin)

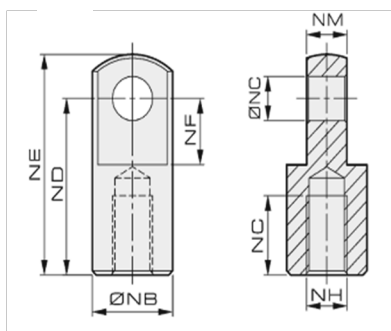

I (Rod Pivot with Pin)								
Symbol/Bore	NB	NC	ND	NE	NF	NG	NH	NM
16	12	5	21	28	8.5	8	M6 x 1	6
20	16	8	30	40	11	15	M8 x 1.25	8
25	20	10	40	50	15	18	M10 x 1.25	10
32	20	10	40	50	15	18	M10 x 1.25	10
40	24	12	48	62	24	18	M12 x 1.25	12

SC & SU Series Cylinder Dimensions

SC / SU

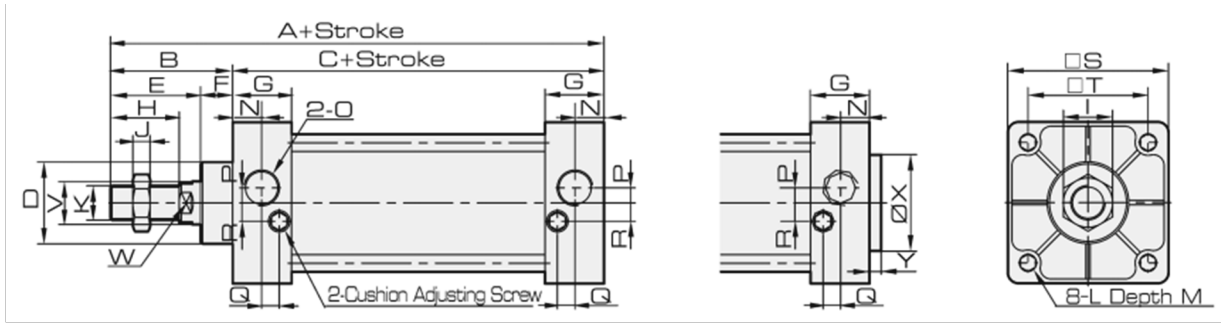

Bore	A	A1	A2	B	C	D	E	F	G	H	I	J	K	L
32	140	187	182	47	93	28	32	15	27.5	22	17	6	M10 x 1.25	M6
40	142	191	185	48	93	32	34	15	27.5	24	17	7	M12 x 1.25	M6
50	150	207	196	57	93	38	42	15	27.5	32	23	8	M16 x 1.25	M6
63	153	210	199	57	96	38	42	15	27.5	32	23	8	M16 x 1.25	M8
80	183	258	243	75	108	47	54	21	33	40	26	10	M20 x 1.25	M10
100	189	264	249	75	114	47	54	21	33	40	26	10	M20 x 1.25	M10
125	226	/	/	104	122	55	70	34	33	54	40	10	M27 x 1.25	M12
160	291	/	/	123	168	62	93	30	50	72	55	18	M36 x 2	M16
200	347	/	/	167	180	80	112	55	50	72	55	18	M36 x 2	M16
250	389	/	/	189	200	90	122	67	54	84	65	21	M42 x 2	M20
320	436	/	/	216	220	110	126	90	65	96	75	24	M48 x 2	M24

Bore	M	N	O	P	Q	R	S	T	V	W	X	Y	Z
32	9.5	13.5	G1/8	3.5	7.5	7	45	33	12	10	/	/	21
40	9.5	13.5	G1/4	6	8.2	9	50	37	16	14	/	/	21
50	9.5	13.5	G1/4	8.5	8.2	9	62	47	20	17	/	/	23
63	9.5	13.5	G3/8	7	8.2	8.5	75	56	20	17	/	/	23
80	11.5	16.5	G3/8	10	9.5	14	94	70	25	22	/	/	29
100	11.5	16.5	G1/2	11	9.5	14	112	84	25	22	/	/	29
125	15.5	16.5	G1/2	10	10	11	140	110	32	27	/	/	/
160	17.5	25	G1/2	/	/	/	180	140	40	36	/	/	/
200	17.5	25	G3/4	/	/	/	220	175	40	36	/	/	/
250	25	31	G1	18.5	5	40	270	220	50	46	90	10	/
320	28	31	G1	35	15	35	350	270	63	55	110	10	/

Front or Rear Flange (FA/FB)

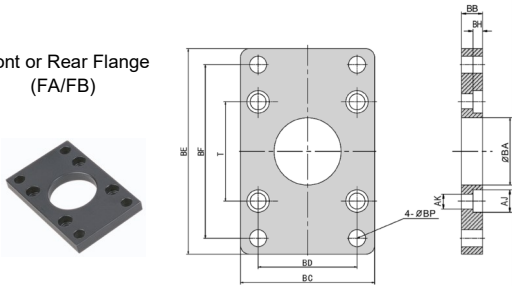

FA/FB (Front or Rear Flange)									
Bore	32	40	50	63	80	100	125	160	200
BA	28.3	32.3	38.3	38.3	47.3	47.5	56	63	81
BB	10	10	10	12	16	16	20	25	25
BC	47	52	65	76	95	115	140	180	220
BD	33	36	47	56	70	84	90	115	135
BE	72	84	104	116	143	162	224	280	320
BF	58	70	86	98	119	138	180	230	270
BG	6.5	6.5	6.5	8.5	11	11	15	20	20
BH	11	11	14	14	17	17	19	25	25
AJ	6.5	6.5	8.5	8.5	11	11	13	17	17
BP	7	7	9	9	12	12	16	18	22
T	33	37	47	56	70	84	110	140	175

Double Rear Clevis Bracket with Pin (CB)

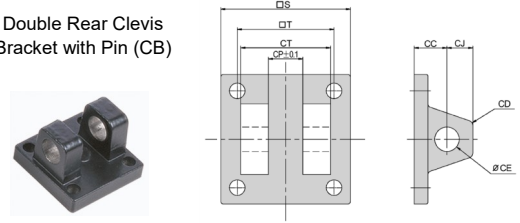

CB (Double Rear Clevis Bracket with Pin)									
Bore	32	40	50	63	80	100	125	160	200
CC	19	19	19	19	32	32	50	55	60
CD	5	5	3	3	8	8	25	30	30
CE	12	14	14	14	20	20	25	30	30
CJ	13	13	15	15	21	21	25	30	30
CP	16	21	20	20	32	32	70	90	90
CT	32	44	52	52	64	64	120	160	160
PAI	41	52	60	60	74	74	130	170	170
PBI	34	46	54	54	66	66	122	162	162
S	48	50	62	75	94	112	140	180	220
T	33	37	47	56	70	84	110	140	175

Swing Type (TC)

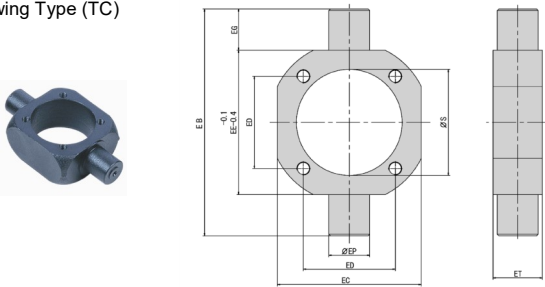

TC (Center Trunnion)								
Bore	40	50	63	80	100	125	160	200
EB	113	126	138	164	182	210	264	336
EC	63	76	88	114	132	160	200	240
ED	37	47	56	70	84	110	140	175
EE	63	76	88	114	132	160	200	240
EG	25	25	25	25	25	25	32	48
EP	25	25	25	25	25	25	32	38
ET	30	30	30	30	30	30	38	44
S	46	56	69	88	108	135	173	213

Foot Mount (LB)

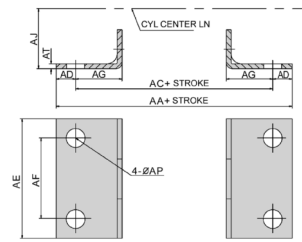

LB (Foot Mount)									
Bore	32	40	50	63	80	100	125	160	200
AA	153	169	173	184	200	210	249	328	380
AC	134	140	149	158	168	174	213	288	320
AD	9.5	15	12	12	16	18	18	20	30
AE	50	57	68	80	97	112	140	180	220
AF	33	36	47	56	70	84	90	115	135
AG	21	24	28	31	30	30	45	60	70
AJ	28	30	37	41	49	57	90	115	135
AP	9	12	12	12	14	14	16	18	22
AT	3.2	3.2	3.2	3.2	4	4	8	8	10

Single Rear Clevis with Pin (CA)

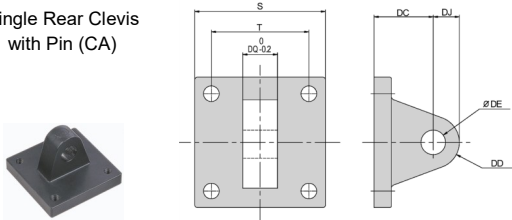

CA (Single Rear Clevis with Pin)									
Bore	32	40	50	63	80	100	125	160	200
S	48	50	62	75	94	112	140	180	220
T	33	37	47	56	70	84	110	140	175
DC	34	34	34	34	48	48	50	55	60
DD	14	14	15	15	20	20	25	30	30
DE	12	14	14	14	20	20	25	30	30
DL	14	14	15	15	20	20	25	30	30
DQ	16	20	20	20	32	32	70	90	90

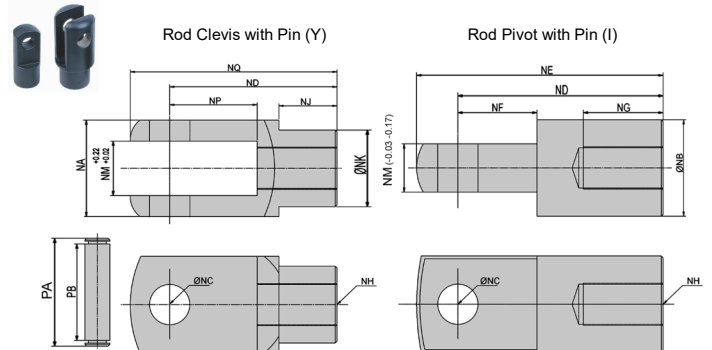

Y (Rod Clevis with Pin), I (Rod Pivot with Pin)															
Bore	NA	NB	NC	ND	NE	NF	NG	NH	NJ	NK	NM	NP	NQ	PA	PB
32	19	20	10	40	52	15	20	M10X1.25	12	18	10	20	52	26	20
40	25	24	12	48	67	24	20	M12X1.25	20	23	12	24	62	33	27
50	32	32	16	64	89	32	23	M16X1.5	22	30	16	32	83	39	33
63	32	32	16	64	89	32	23	M16X1.5	22	30	16	32	83	39	33
80	44	40	20	80	112	40	30	M20X1.5	30	39	20	40	105	53	45
100	44	40	20	80	112	40	30	M20X1.5	30	39	20	40	105	53	45

SDA & SSA Series Compact Cylinder Dimensions

SDA

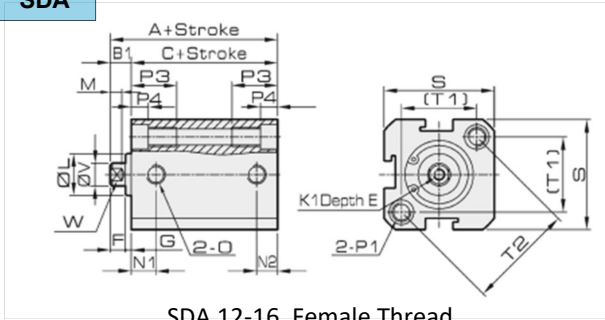

SDA 12-16, Female Thread

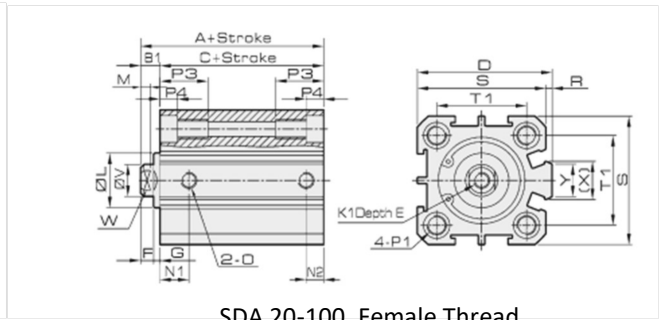

SDA 20-100, Female Thread

SSA



SSA 12-16, Female Thread

SDA 20-63, Female Thread

Symbol / Stroke	SDA						SSA											B1	D	E	F	G	
	Standard Type			With Magnet			Standard Type						With Magnetic Piston										
	A	B	C	A	B	C	A		B		C		A		B								
Bore							≤10	>10	≤10	>10	≤10	>10	≤10	>10	≤10	>10	≤10	>10					
12	22	34	17	32	44	27	32	42	44	54	27	37	42	52	54	64	37	47	5	-	6	4	2
16	24	36	18.5	34	46	28.5	34	44	46	56	28.5	38.5	44	54	56	66	38.5	48.5	5.5	-	6	4	2
20	25	40	19.5	35	50	29.5	35	45	50	60	29.5	39.5	45	55	60	70	39.5	49.5	5.5	36	8	4	1.5
25	27	44	21	37	54	31	37	47	54	64	31	41	47	57	64	74	41	51	6	42	10	4	2
32	31.5	49.5	24.5	41.5	59.5	34.5	41.5	51.5	59.5	69.5	34.5	44.5	51.5	61.5	69.5	79.5	44.5	54.5	7	50	12	4	3
40	33	61	26	43	71	36	43	53	71	81	36	46	53	63	81	91	46	56	7	58.5	12	4	3
50	37	65	28	47	75	38	47	57	75	85	38	48	57	67	85	95	48	58	9	71.5	15	5	4
63	41	69	32	51	79	42	51	61	79	89	42	52	61	71	89	99	52	62	9	84.5	15	5	4
80	52	85	41	62	95	51	62	72	95	105	51	61	72	82	105	115	61	71	11	104	20	6	5
100	63	101	51	73	111	61	73	83	111	121	61	71	83	93	121	131	71	81	12	124	20	7	5
Symbol / Stroke	H	I	J	K	K1	L	M	N1		N2		O	P1/DIA	P3	P4	R	S	T1	T2	V	W	X	Y
Bore								S = 5	S > 5	S = 5	S > 5												
12	12	M5 x 0.8	4	8	M3 x 0.5	10	3	7.5	5.5	M5X0.8	M5 x 0.8 x 4.2	12	4.5	-	25	16.3	23	6	5	-	-	-	
16	12	M5 x 0.8	4	8	M3 x 0.5	11	3	8	5	5.5	M5X0.8	M5 x 0.8 x 4.2	12	4.5	-	29	19.8	28	6	5	-	-	
20	15	M6 x 1.0	5	10	M4 x 0.7	13	3	8.5	5.5	M5X0.8	M5 x 0.8 x 4.2	14	4.5	2	34	24	-	8	6	11.2	10		
25	17	M8 x 1.25	6	14	M5 x 0.8	17	3	9	5.5	M5X0.8	M6 x 1.0 x 4.6	15	5.5	2	40	28	-	10	8	12	10		
32	18	M10 x 1.25	6	17	M6 x 1.0	22	3	9	6.5	8	G1/8	M6 x 1.0 x 4.6	16	5.5	6	44	34	-	12	10	18	14	
40	28	M14 x 1.5	8	22	M8 x 1.25	28	3	9	7.5	G1/8	M8 x 1.25 x 6.7	20	7.5	6.5	52	40	-	16	14	21	14		
50	28	M18 x 1.5	9	27	M10 x 1.5	38	3	8	10.5	8	10.5	G1/4	M8 x 1.25 x 6.7	25	8.5	9.5	62	48	-	20	17	29.5	19
63	28	M18 x 1.5	9	27	M10 x 1.5	40	3	9.5	11	9.5	11	G1/4	M8 x 1.25 x 6.7	25	8.5	9.5	75	60	-	20	17	26	19
80	33	M22 x 1.5	13	32	M14 x 1.5	45	4	11.5	14	11.5	14	G3/8	M12 x 1.75 x 9.2	25	10.5	10	94	74	-	25	22	36	26
100	38	M26 x 1.5	12	36	M18 x 1.5	55	4	15	20	15	18	G3/8	M14 x 2 x 11.3	30	13	10	114	90	-	32	27	35.5	26

Terms and Conditions

By purchasing from SIZTO TECH CORPORATION (STC), you agree to these TERMS AND CONDITIONS. No other terms shall apply except as agreed in writing signed by us. We reserve the right to correct typographic errors and reject orders.

SHIPMENTS:

All shipments are F.O.B. 892 Commercial Street, Palo Alto, CA 94303, USA. Most orders are shipped via UPS Standard Ground unless instructions accompany order. Outside the UPS zones, shipment will be made Best Way. The responsibility for goods delay, lost or damaged in transit rests with the carrier and purchaser. Purchaser may purchase shipping insurance to cover lost or damaged products caused by shipping.

RETURN OF MERCHANDISE:

No merchandise is accepted for return 30 days after delivery date. No credit allowed on merchandise shipped as ordered and returned without obtaining an authorization number IN ADVANCE. A 20% restocking charge applies to all returns, and transportation charges must be fully prepaid. We will pay **ground** transportation charges on re-sent or returned merchandise due to STC's error.

Shortages & Mis-Shipments: Any shortages or mis-shipment must be reported within 15 days.

CANCELLATION POLICY:

Blanket orders can be canceled 90 days before scheduled ship date. There will be a 10% charge if a blanket order is cancel within 90 days of scheduled ship date, and a 20% charge if cancel within 60 days. Regular order for non-custom parts can be canceled any time before the order is shipped. For custom parts, a 30% down payment is required either at the time of order or 90 days prior to scheduled ship date, whichever comes later.

Remittances should be sent to:

Sizto Tech Corporation, 892 Commercial Street, Palo Alto, CA 94303, USA.

Credit Card Payments: Visa, MasterCard, Discover, or American Express Accepted.

International Customers: Advance Payment Required via Bank Wire, Cashier's Check or Approved Credit Card.

Credit Application: To establish a net 30 day account, please mail or fax three trade references with complete mailing addresses and account numbers.

LIMITED WARRANTY – IMPORTANT NOTICE TO PURCHASER:

Sizto Tech Corporation (STC) only warrants this product to be free from defects in materials and workmanship at the time of shipment. This limited warranty expires one year after delivery to the end-user. STC's entire obligation to the Purchaser for breach of this limited warranty shall be limited to replacement of the defective product or refund of the original purchase price of this product, at STC's option. Purchaser has thirty (30) days to return the goods after STC has agreed to accept the return. All freight charges on returned material shall be paid by the Purchaser. STC's limited warranty shall not apply, however, to the product that have been subjected to misuse, alteration, accident or negligence during handling or storage.

DISCLAIMER OF IMPLIED WARRANTIES:

All implied warranties, which may arise by implication of law or application of course of dealing or usage of trade, including, but not limited to, implied warranties of merchantability or fitness for a particular purpose are expressly excluded. There are no warranties, which extend beyond the description of the faced hereof. The end user is solely responsible for the suitability and fitness of this product selected for a particular application.

OBLIGATIONS

You warrant, represent and agree: (1) to comply with all laws; (2) that our sale and shipment of the product will not, by export thereof, your legal status or otherwise, cause us to violate any law; and (3) to indemnify us against any losses from a failure by you or a third party to comply with law or these terms and conditions, or from use of the product.

SAFETY WARNING

Failure or improper selection or improper use of the components and products described herein or related items can cause death, personal injury and/or property damage. This document and other related information from STC provide products options for further investigation by users having the technical expertise. It is important that you analyze all aspects of your application and review the information concerning the component or product in the current catalog. Due to the variety of operation conditions and applications for these components or products, the user, through his own analysis and testing, is solely responsible for making the final selection, installation and maintenance of the products and assuring that all performance, safety and warning requirements of the application are met. All products set-ups and maintenance require the supervision of a qualified individual who is familiar with installation, inspection and testing through training or experience.

IMPORTANT NOTICE:

The products described herein, including without limitation, product features, specifications, design, availability and pricing, are subject to change without notice. We continuously improve the products, and we reserve the right to change specifications without incurring any obligation to incorporate new factors in equipment previously sold.

Distributed By:



Sizto Tech Corporation

892 Commercial Street

Palo Alto, CA 94303 USA

Tel: (650) 856-8833 | Fax: (650) 856-8811

Email: Sales@StcValve.com; www.StcValve.com