

3A120-420 SERIES AIR PILOT VALVE



Valve Model	3A120-1/8	3A220-1/4	3A320-3/8	3A420-1/2
Port & Mounting	Body Ported			
Action & Motion	Double Air Pilot, Spool Design			
Operating Pressure	Valve: 0 to 115 PSI, Pilot: 40 PSI			
Port Sizes	1/8 NPT	1/4 NPT	3/8 NPT	1/2 NPT
C _v	0.67	0.78	1.68	2.79
SFCM @ 100PSI	25	53	80	160
Working Medium	40 micron filtered air or inert gas			
Valve Body Material	Anodized Aluminum			
Seal Material	NBR (Buna N)			
Lubrication	Not Required			

3A120-420 SERIES AIR PILOT VALVE DIMENSIONS

MODEL: 3A120-1/8

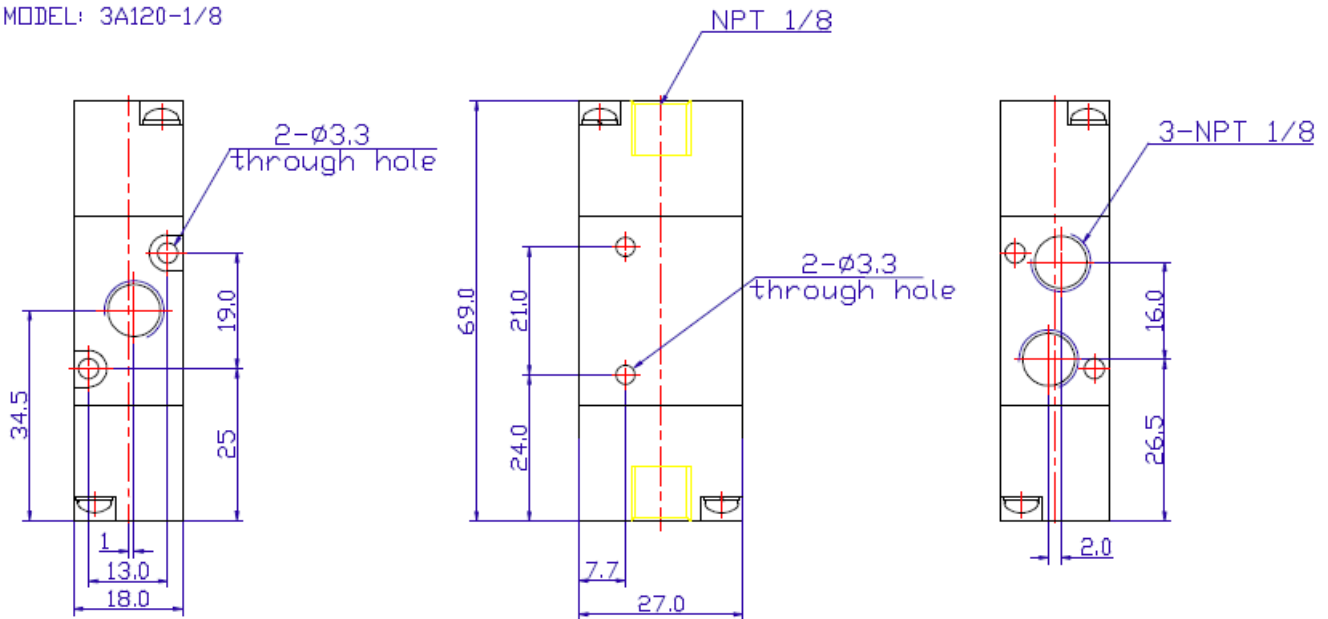

MODEL: 3A220-1/4

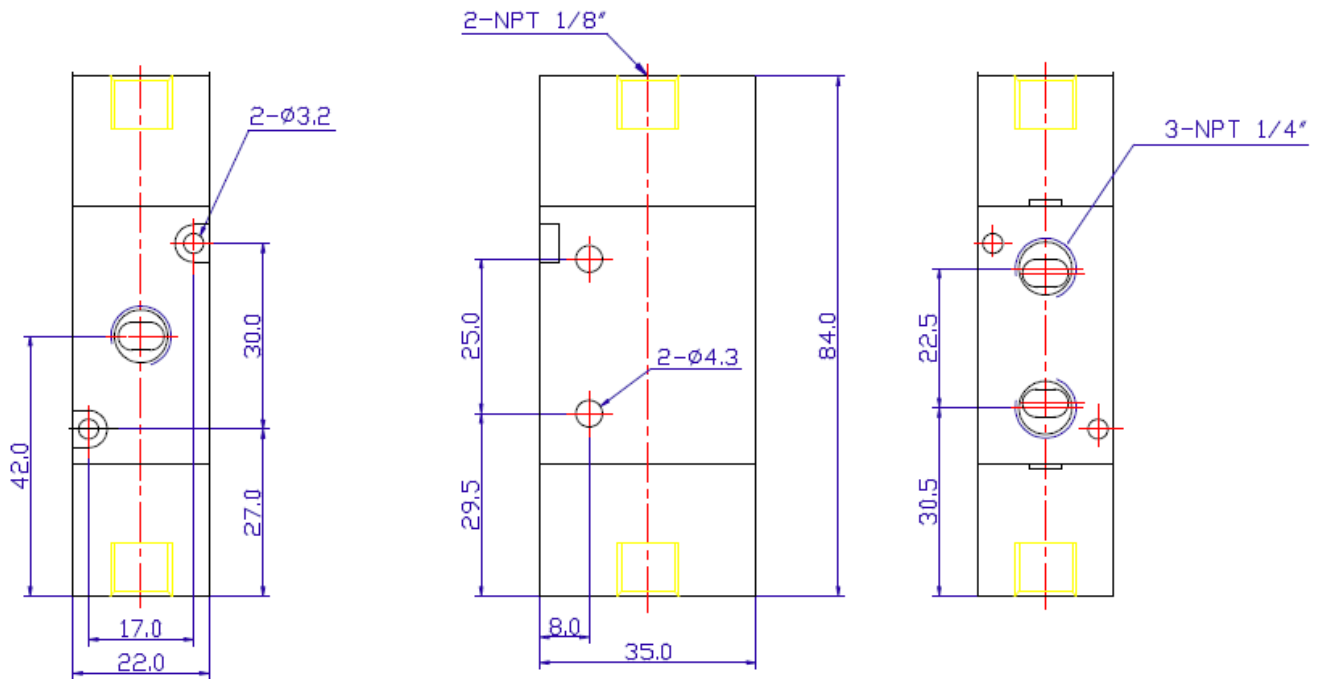

3A120-420 SERIES AIR PILOT VALVE DIMENSIONS

MODEL: 3A320-3/8

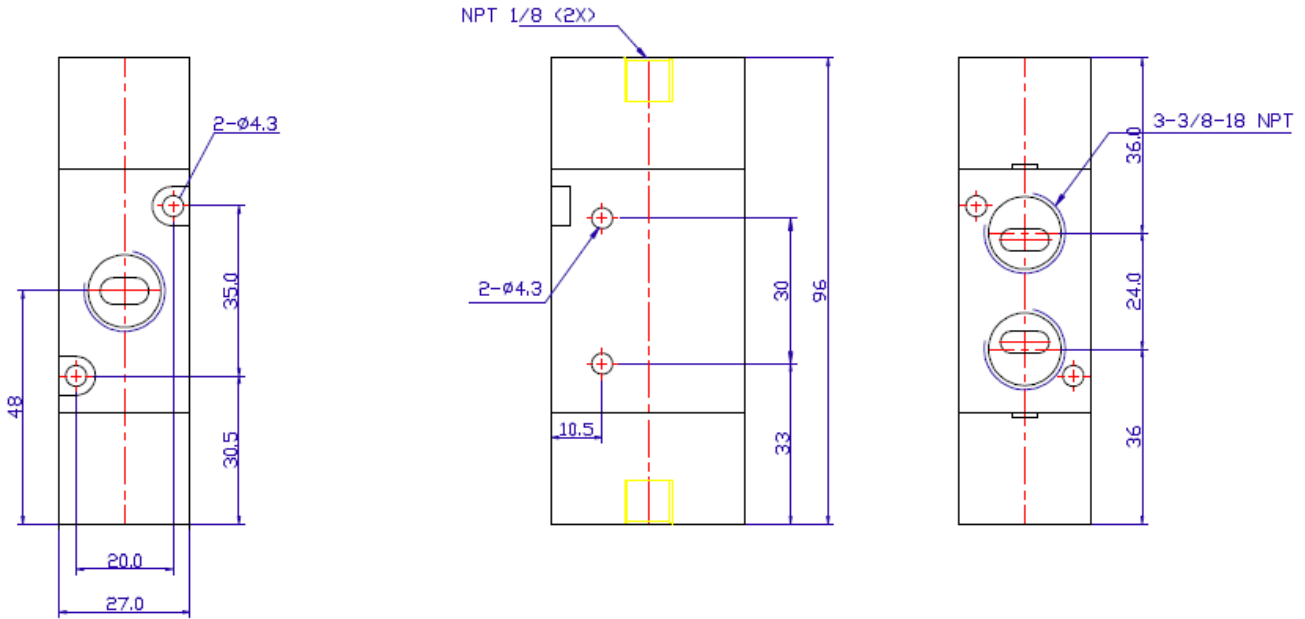

TYPE: 3A420-1/2

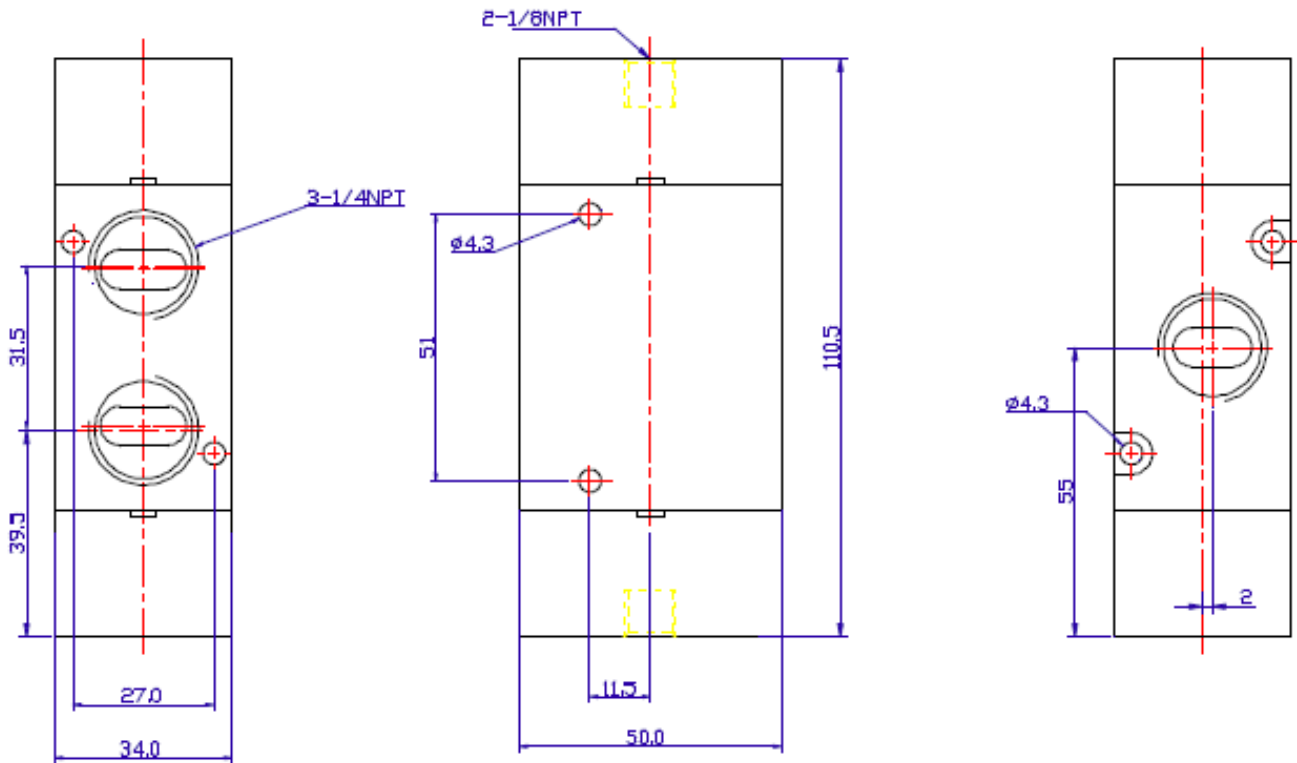
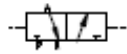

3-Way 2 Air Pilot Valve

Models 3A120-3A420

Installation Procedure

Note:

- This valve is designed for air flow only.
- Make sure the pilot sources are operating at pressures specified for the valve.

Attaching the Pilot Source to a Valve:

1. Attach connector to the pilot port.
2. Connect pilot source to connector.

Installing a Valve onto a Manifold:**Note:**

- Manifolds can fit 2, 4, 6, 8 and 16 valves.
- Secure screws until the component will not move freely, and tighten another quarter turn.

Procedure:

1. Place a rubber seal over the manifold openings.
2. Line up the valve with port “A” and corresponding pilot holes for the screws.
3. Secure the valve into place.
4. Cover the remaining holes with the provided gaskets.

Installation:

1. Connect the source to the port labeled “P”.
2. Connect the outlet to the port labeled “A”.
3. Connect the exhaust to the port labeled “EA”.

Operational Notes

- A continuous air supply is not required to maintain the solenoid position.
- To move the piston to a new position, activate the appropriate pilot source. Do not activate both pilots at the same time.

Maintenance and Troubleshooting

Procedure:

1. Remove any pilot connections attached to the valve.
2. Unscrew the pilot block and remove the piston and spring.
3. Check for any debris that may have collected on the piston and in the hole in the center of the valve.
4. Insert the piston and spring back into the valve body.
5. Screw the pilot block back into the valve.

Reference Figures

Figure 1: Model 3A220 with port labels and a pilot port shown.

STC Installation and Operation Procedure

3A120-420 & 4A120-420 Air Pilot Valves

3A120-420 (3 way valve)

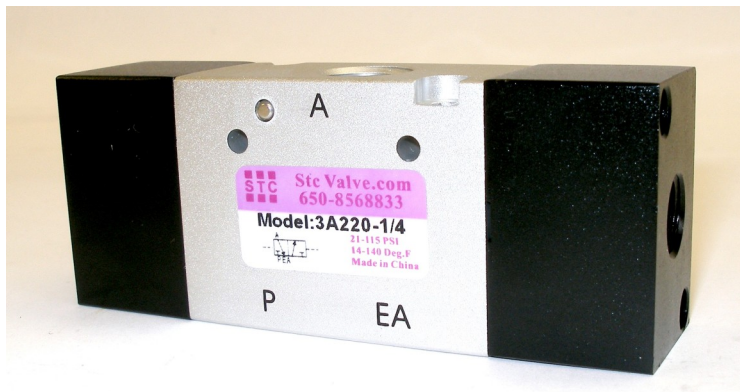
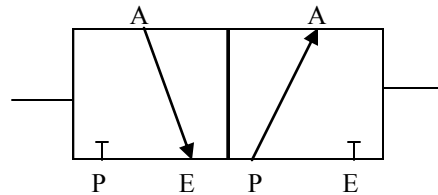

VALVE POSITION 1 2

Operations:

1. When Valve is in Position 1, Port A is connected to Port E. Port P is closed
2. When Valve is in Position 2, Port P is connected to Port A. Port E is closed.

4A120-420 (4 way valve)

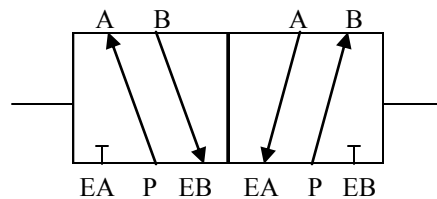

VALVE POSITION 1 2

Operations:

1. When Valve is in Position 1, Port P is connected to Port A. Port B is connected to Port EB.
2. When Valve is in Position 2, Port P is connected to Port B. Port A is connected to Port EA.

Terms and Conditions

By purchasing from SIZTO TECH CORPORATION (STC), you agree to these TERMS AND CONDITIONS. No other terms shall apply except as agreed in writing signed by us. We reserve the right to correct typographic errors and reject orders.

SHIPMENTS:

All shipments are F.O.B. 892 Commercial Street, Palo Alto, CA 94303, USA. Most orders are shipped via UPS Standard Ground unless instructions accompany order. Outside the UPS zones, shipment will be made Best Way. The responsibility for goods delay, lost or damaged in transit rests with the carrier and purchaser. Purchaser may purchase shipping insurance to cover lost or damaged products caused by shipping.

RETURN OF MERCHANDISE:

No merchandise is accepted for return 30 days after delivery date. No credit allowed on merchandise shipped as ordered and returned without obtaining an authorization number IN ADVANCE. A 20% restocking charge applies to all returns, and transportation charges must be fully pre-paid. We will pay **ground** transportation charges on re-sent or returned merchandise due to STC's error.

Shortages & Mis-Shipments: Any shortages or mis-shipment must be reported within 15 days.

CANCELLATION POLICY:

Blanket order can be canceled 90 days before scheduled ship date. There will be a 10% charge if a blanket order is cancel within 90 days of scheduled ship date, and a 20% charge if cancel within 60 days. Regular order for non-custom parts can be canceled any time before the order is shipped. For custom parts, a 30% down payment is required either at the time of order or 90 days prior to scheduled ship date, whichever comes later.

Remittances should be sent to:

Sizto Tech Corporation, 892 Commercial Street, Palo Alto, CA 94303, USA

Credit Card Payments: Visa, MasterCard, Discover, or American Express Accepted

International Customers: Advance Payment Required via Bank Wire, Cashier's Check or Approved Credit Card.

Credit Application: To establish a net 30 day account, please mail or fax three trade references with complete mailing addresses and account numbers.

LIMITED WARRANTY – IMPORTANT NOTICE TO PURCHASER:

Sizto Tech Corporation (STC) only warrants this product to be free from defects in materials and workmanship at the time of shipment. This limited warranty expires one year after delivery to the end-user. STC's entire obligation to the Purchaser for breach of this limited warranty shall be limited to replacement of the defective product or refund of the original purchase price of this product, at STC's option. Purchaser has thirty (30) days to return the goods after STC has agreed to accept the return. All freight charges on returned material shall be paid by the Purchaser. STC's limited warranty shall not apply, however, to the product that have been subjected to misuse, alteration, accident or negligence during handling or storage.

DISCLAIMER OF IMPLIED WARRANTIES:

All implied warranties, which may arise by implication of law or application of course of dealing or usage of trade, including, but not limited to, implied warranties of merchantability or fitness for a particular purpose are expressly excluded. There are no warranties, which extend beyond the description of the faced hereof. The end user is solely responsible for the suitability and fitness of this product selected for a particular application.

OBLIGATIONS

You warrant, represent and agree: (1) to comply with all laws; (2) that our sale and shipment of the product will not, by export thereof, your legal status or otherwise, cause us to violate any law; and (3) to indemnify us against any losses from a failure by you or a third party to comply with law or these terms and conditions, or from use of the product.

SAFETY WARNING

Failure or improper selection or improper use of the components and products described herein or related items can cause death, personal injury and/or property damage. This document and other related information from STC provide products options for further investigation by users having the technical expertise. It is important that you analyze all aspects of your application and review the information concerning the component or product in the current catalog. Due to the variety of operation conditions and applications for these components or products, the user, through his own analysis and testing, is solely responsible for making the final selection, installation and maintenance of the products and assuring that all performance, safety and warning requirements of the application are met. All products set-ups and maintenance require the supervision of a qualified individual who is familiar with installation, inspection and testing through training or experience.

IMPORTANT NOTICE:

The products described herein, including without limitation, product features, specifications, design, availability and pricing, are subject to change without notice. We continuously improve the products, and we reserve the right to change specifications without incurring any obligation to incorporate new factors in equipment previously sold.



Sizto Tech Corporation

892 Commercial Street
Palo Alto, CA 94303 USA

Tel: 650-856 8833 | Fax: 650-856 8811

Email: Sales@StcValve.com; www.StcValve.com